

D2.3 Re-design and stress test of NextGen selected case study systems

AUTHORS :

JORDI CROS, IÑAKI BARRONDO, JORGE GALINDO (ADASA),
STAVROULA MANOURI (NTUA), DIMITRIOS BOUZIOTAS (KWR),
KLIO MONOKROUSOU (NTUA), CHRISTOS MAKROPOULOS (NTUA),
JAN HOFFMAN (UNIVERSITY OF BATH)

DATE : 30.07.2022



Technical References

Project Acronym	NextGen
Project Title	Towards a next generation of water systems and services for the circular economy
Project Coordinator	KWR
Project Duration	48 Months

Deliverable No.	D2.3
Dissemination level 1	PU
Work Package	WP2
Task	T2.3
Lead beneficiary	ADASA
Contributing beneficiary(ies)	ICCS, NTUA, UNEXE, STRANE
Due date of deliverable	M51 (30/07/2022)
Actual submission date	30/07/2022

- ¹
- PU = Public
 - PP = Restricted to other programme participants (including the Commission Services)
 - RE = Restricted to a group specified by the consortium (including the Commission Services)
 - CO = Confidential, only for members of the consortium (including the Commission Services)

Document history

V	Date	Beneficiary	Author
1	10/05/2019	ADASA	Jordi Cros
2	23/02/2022	UBATH	Jan Hofman (Section 4.1)
3.1	23/05/2022	ALL	All (version for external reviewers)
3.2	12/07/2022	ALL	All (version with recommendations of reviewers)
3.3	21/07/2022	ALL	All (final version)



Summary

Objective of Task 2.3 is to evaluate the modelling tools from the NextGen Toolbox tools (<https://mp.uwmh.eu/l/Product/>) in selected demo cases inside the scope of the project. The work performed in this deliverable is focusing on the individual solution levels from T2.2 and extend our assessment both in terms of scale and in terms of time.

The HydrOptim and UWOT (Urban Water Optioneering Tool) have been used to model the selected system to evaluate, compare and optimise the configuration of the system to improve the overall cycle's performance.

- HydrOptim has been used to demonstrated cases studies with regional water management, as Costa Brava and Delfland.
- UWOT has been used to demonstrated cases studies on the city/neighbourhood water management, as Athens, Delfland and Filton Airport

Also, the long-term Resilience of the 'Optimal/eco-efficient' solutions has been executed, with stress test of these systems against current operational scenarios as well as future climatic, environmental, and socio-economic scenarios, developed in collaboration with CoPs and trace their performance using a resilience framework.

NextGen tools HydrOptim has shown its capabilities to modelized and optimize the cost of the water networks, and UWOT has shown its capability of modelling both the supply and demand characteristics of the system within the same model

Keywords: Recommender Tool, web-based application, water CE stakeholders, Technologies



Disclaimer

Any dissemination of results must indicate that it reflects only the author's view and that the Agency and the European Commission are not responsible for any use that may be made of the information it contains.



Table of Contents

TECHNICAL REFERENCES	2
DOCUMENT HISTORY	2
SUMMARY	3
DISCLAIMER	4
TABLE OF CONTENTS	5
TABLE OF FIGURES	8
TABLE OF TABLES	11
LIST OF ABBREVIATIONS	12
1. INTRODUCTION	13
1.1. PURPOSE OF THIS DOCUMENT	13
1.2. INTENDED READERSHIP	13
1.3. RELATIONSHIP WITH OTHER NEXTGEN TASKS/WPS	13
1.4. DOCUMENT'S STRUCTURE	14
2. THE TOOLS	15
2.1. HYDROPTIM	15
2.1.1. HydrOptim components	18
2.2. UWOT	21
3. THE COSTA BRAVA DEMO CASE (HYDROPTIM)	22
3.1. THE MODEL FOR COSTA BRAVA	23
3.1.1. Elements of the Model	25
3.1.2. Initial Scenarios	27
3.2. RESULTS OF INITIAL SCENARIO	30
3.2.1. Volume of supply	30
3.2.2. Total Energy	31
3.2.3. Energy consumption by type	32
3.2.4. Energy consumption by element	33
3.3. THE STRESS TESTING	34
3.3.1. Volume of supply in Stress test	34
3.3.2. Total Energy in Stress Test	35
3.3.3. Energy consumption by type in Stress test	36
3.3.4. Energy consumption by element in Stress test	37
4. THE DELFLAND DEMO CASE (HYDROPTIM)	38
4.1. MODELS FOR DELFLAND	39
4.1.1. Elements of the model	40



4.1.2.	Initial Scenarios	42
4.2.	RESULTS OF INITIAL SCENARIOS	44
4.2.1.	Base line	44
4.2.2.	Scenario 1	45
4.2.3.	Scenario 3	47
4.3.	THE STRESS TESTING	51
4.3.1.	Scenario 1	51
4.3.2.	Scenario 3	56
5.	<u>THE ATHENS DEMO CASE (UWOT)</u>	62
5.1.	DESCRIPTION OF THE SET-UP	62
5.1.1.	Modelling in Urban Water Optioneering Tool (UWOT)	63
5.2.	ATHENS	64
5.2.1.	Multi-criteria analysis in GIS environment for the identification of potential sewer mining locations	66
5.2.2.	Chosen parks for implementing an upscaling approach	67
5.2.3.	Modelling in UWOT and results	69
5.3.	THE STRESS TESTING	71
5.3.1.	Examination of three different scenarios of demand covered by sewer mining units	71
5.3.2.	Results: Resilience curve and Resilience-cost diagram	71
6.	<u>THE DELFLAND DEMO CASE (UWOT)</u>	75
6.1.	DATA PREPARATION	77
6.2.	UWOT BASELINE MODEL	79
6.2.1.	UWOT baseline model setup (BAU)	79
6.2.2.	Validation of the baseline setup	83
6.3.	SCENARIOS ANALYSIS	85
6.3.1.	Preparation of the circular redesign scenarios	85
6.3.2.	UWOT circular redesign models setup	91
6.3.3.	Redesign results at the coarse scale	94
6.3.4.	Redesign results at the fine scale	106
6.4.	THE STRESS TESTING	108
7.	<u>THE FILTON AIRFIELD DEMO CASE (UWOT)</u>	116
7.1.	CASE DESCRIPTION	116
7.2.	RESULTS	118
8.	<u>CONCLUSIONS</u>	121
8.1.	HYDROPTIM	121
8.1.1.	Conclusions	121
8.1.2.	Lessons learned	122
8.1.3.	Future Plans	122
8.2.	UWOT	122
8.2.1.	Conclusions	122



8.2.2.	Lessons learned	123
9.	REFERENCES	124
10.	PRIVACY POLICY	126



Table of Figures

Figure 1 HydrOptim structure	15
Figure 2 HydrOptim technical architecture.....	16
Figure 3 Hydroptim architecture	17
Figure 4 Example of List of scenarios	18
Figure 5 Example of definition of elements	20
Figure 6 Modeling the urban water cycle from tap to source using UWOT (adapted from Makropoulos C. (2017))	21
Figure 7 Map of Costa Brava demo case	22
Figure 8 Hydraulic model for Costa Brava demo case	23
Figure 9 Model of Costa Brava demo case (Screen copy from HydrOptim tool)	24
Figure 10 Detail of water demand elements of Costa Brava demo case (Screen copy from HydrOptim tool).....	24
Figure 11 Available volume (m ³) from aquifer	28
Figure 12 Available volume (m ³) per month	28
Figure 13 Total Energy consumed	29
Figure 14 Distribution of water supplied in Real Scenarios	31
Figure 15 Total energy consumption (€) in Real Scenarios	31
Figure 16 Energy consumption (€) by element type in Real Scenarios	32
Figure 17 Energy consumption by different element in different Scenarios	33
Figure 18 Volume of supply in Stress testing Scenarios	35
Figure 19 Total energy consumption (€) by element in Stress testing Scenarios	35
Figure 20 Energy consumption (€) by element in Stress testing Scenarios	36
Figure 21 Energy consumption (€) by element in Stress testing Scenarios	37
Figure 22 Map of Delfland demo case.....	38
Figure 23 Model of the base-line of Delfland demo case	39
Figure 24 Hydraulic model of the base-line of Delfland demo case	40
Figure 25 Rain flow used (FluxesDaily_Waterbank_Region_waterbank_basisscenario.xlsx).....	41
Figure 26 Greenhouse demand used (FluxesDaily_Waterbank_Region_waterbank_basisscenario.xlsx)	41
Figure 27 Cities demand used (Concentraties_en_vrachten_in_de_waterlijn_r2.1.0.xlsx)	41
Figure 28 Model of the scenario 1a and 1b of Delfland demo case.....	42
Figure 29 Model of the scenario 2 of Delfland demo case	42
Figure 30 Model of the scenario 3 of Delfland demo case	43
Figure 31 Hydroptim model of the baseline of Delfland demo case.....	44
Figure 32 Main flows for base line model.....	45
Figure 33 Changes in base line to implement Scenario 1.....	45
Figure 34 WaterNode_3	45
Figure 35 Flows in Pipe of WaterNode_3 for Scenario 1	46
Figure 36 WaterNode_9	46
Figure 37 Flows in Pipe of WaterNode_9 for Scenario 1	47
Figure 38 Changes in base line to implement Scenario 3.....	47
Figure 39 WaterNode_4 (left) and WaterNode_3 (right)	48
Figure 40 Flows in Pipe of WaterNode_4 for Scenario 3	48
Figure 41 Flows in Pipe of WaterNode_3 for Scenario 3	49
Figure 42 Flows in Pipe of WaterNode_4 for Scenario 3	49
Figure 43 Flows in Pipe of WaterNode_3 for Scenario 3	50
Figure 44 Scenario 1a modified for stress test.....	51
Figure 45 Cost of transport between branches (left). Cost of rain in the fields (right).....	52
Figure 46 Total cost (€), including all network costs	53



Figure 47 Identification of variables for Scenario 1	53
Figure 48 Different flows for Scenario 1, V0	53
Figure 49 Different flows for Scenario 1, V1	54
Figure 50 Different flows for Scenario 1, V2	54
Figure 51 Different flows for Scenario 1, V3	55
Figure 52 Scenario 3 modified for stress test	56
Figure 53 Cost of transport (€) between branches (left). Cost of rain in the fields (right)	57
Figure 54 Total cost (€), Including all network costs	57
Figure 55 Identification of variables for Scenario 3	58
Figure 56 Different flows for Scenario 3, V0	58
Figure 57 Different flows for Scenario 3, V1	59
Figure 58 Different flows for Scenario 3, V2	59
Figure 59 Different flows for Scenario 3, V3	60
Figure 60 Different flows for Scenario 3, V4	60
Figure 61 The Athens pilot flow diagram for water and material recovery	62
Figure 62 Diagram of the processes in the Nursery’s sewer mining set-up	63
Figure 63 The set-up consisting of a sewer mining unit in UWOT	64
Figure 64 Green urban areas in the region of Athens	65
Figure 65 Results of multi-criteria analysis in GIS environment	66
Figure 66 Rizari Park’s location in Athens	67
Figure 67 Rizari Park	67
Figure 68 Antonis Tritsis Metropolitan Park’s location in Athens (Source: Google Earth)	68
Figure 69 Antonis Tritsis Metropolitan Park	68
Figure 70 Resilience curve	72
Figure 71 Resilience - Cost diagram	74
Figure 72 Location of Delfland in the Netherlands (left), along with a more detailed regional view (right)	75
Figure 73 The current water management system in horticulture (left), and a more sustainable alternative (right)	76
Figure 74 Schematic of the data preparation scheme that utilizes a reference database for model input and output.	78
Figure 75 Overview of the Delfland geodatabase that was used to prepare the UWOT model. The different CORINE land use classes are visible against the orthophoto of the area, along with the municipality (gemeente) borders with red dotted lines.	79
Figure 76 Further disaggregation of CORINE housing cells in rooftops, public pervious and public impervious areas.	80
Figure 77 Schematic of the horticulture system components in UWOT	81
Figure 78 Overview of the baseline (BAU) UWOT topology for the combined urban-rural water system.	82
Figure 79 Observed and modelled distribution of DW services	84
Figure 80 Mapping of the five initial redesign scenarios for Delfland.	87
Figure 81 Results of the redesign scenario evaluated by the 2 nd Delfland CoP participants.	88
Figure 82 Overview of the GREEN scenario topology in UWOT for the combined urban-rural water system	92
Figure 83 Overview of the WW2G scenario topology in UWOT for the combined urban-rural water system	93
Figure 84 Model results in terms of household demands at the tap level.	97
Figure 85 Sankey diagram of the UWOT baseline (BAU) case.	98
Figure 86 Sankey diagram of the UWOT CIRC redesign scenario	99
Figure 87 Sankey diagram of the UWOT WATWISE redesign scenario	100
Figure 88 Sankey diagram of the UWOT GREEN redesign scenario	101
Figure 89 Sankey diagram of the UWOT WW2G redesign scenario.	102



Figure 90 Results of redesign scenarios at the (inter-)annual scale..... 104

Figure 91 Results of redesign scenarios as average monthly flows. 105

Figure 92 Fine-scale results of the response of the greenhouses in the conventional scenarios (i.e. without waterbanking). 106

Figure 93 Fine-scale results of the response of the greenhouse system when circular redesigns are introduced. 107

Figure 94 The concept of resilience in water systems (source: (Nikolopoulos et al., 2021))..... 109

Figure 95 Resilience against increasing DW demands using the RCE metric..... 110

Figure 96 Resilience against increasing DW demands using the PC metric. 111

Figure 97 Resilience of the WW influx to WWTP using the RCE metric..... 112

Figure 98 Resilience against increasing horticulture demands using the RDD metric..... 113

Figure 99 Resilience against increasing horticulture demands using the SC metric. 114

Figure 100 Resilience against possible future climates using the RDD metric..... 115

Figure 101 Resilience against possible future climates using the SC metric..... 115

Figure 102 Phase 1 Residential area..... 116

Figure 103. Simplified urban water cycle model. 117

Figure 104 Urban Water Optioneering Tool Simulation Model. 120



Table of Tables

Table 1 Maximum Water abstraction per source in the Costa Brava demo case	25
Table 2 Reservoirs of Costa Brava demo case	25
Table 3 Water demands of Costa Brava demo case.....	25
Table 4 Water Treatment Plants of Costa Brava demo case.....	26
Table 5 Pumps of Costa Brava demo case.....	26
Table 6 Water availability from aquifer for Scenarios for Costa Brava demo case.....	27
Table 7 Water supplied from aquifer and energy consumed	29
Table 8 Distribution of water supplied in Real Scenarios.....	30
Table 9 Distribution of Energy consumption by type in Real Scenarios.....	32
Table 10 Energy consumption by element in Real Scenarios.....	33
Table 11 Volume of supply in Stress testing Scenarios	34
Table 12 Energy consumption by type in Stress Testing Scenarios.....	36
Table 13 Energy consumption variation by element in Stress testing Scenarios.....	37
Table 14 Elements of Delfland model	40
Table 15 Costs defined	51
Table 16 Summary table of stress test for Scenario 1.....	52
Table 17 Cost result table of stress test for Scenario 1.....	52
Table 18 Summary table of stress test for Scenario 3 in stress testing	56
Table 19 Cost results table	57
Table 20 Collected data and data sources	64
Table 21 Assumptions related to the population and the daily wastewater supply	69
Table 22 Results of simulation in UWOT tool.....	69
Table 23 Other results	70
Table 24 Cost-related results	70
Table 25 Demand and reliability results for Athens water supply system.....	72
Table 26 Resilience score of three demand coverage scenarios	73
Table 27 Energy cost for Athens' water supply system	73
Table 28 Total cost of three demand coverage scenarios	73
Table 29 Assessment of the land uses in the region of Westland.	77
Table 30 Assessment of the land uses in the region of Westland.	80
Table 31 Modelled wastewater results against other data sources.	84
Table 32 Modelled drinking water results against other data sources.....	85
Table 33 Results of the horticulture system in BAU against other data sources.....	85
Table 34 Overview of the redesign scenarios parameterization	89
Table 35 Best case scenario results.....	118
Table 36 Worst case scenario results.....	118
Table 37 Additional results from the simulations.....	118



List of Abbreviations

CA	Consortium Agreement
CO	Confidential
DoA	Description of Activities, referring to the Annex I of the Grant Agreement
DP	Desalination Plant
EC	European Commission
GA	Grant Agreement
ICT	Information and communication technologies
IPR	Intellectual Property Rights
KPI	Key Performance Indicators
PPR	Project Progress Reports
PSB	Project Steering Board
PU	Public
QA	Quality Assurance
QC	Quality Control
STC	Scientific and Technical Committee
TEB	Technology Evidence Base
URWS	Urban-regional water system
UWOT	Urban Water Optioneering Tool
WP	Work Package
WTP	Water Treatment Plant
WWTP	Wastewater Treatment Plant



1. Introduction

1.1. Purpose of this document

The NextGen projects evaluates and champions innovative and transformational circular economy solutions and systems that challenge embedded thinking and practices around resource use in the water sector. NextGen has demonstrate innovative technological, business and governance solutions for water in the circular economy in ten high-profile, large-scale, demonstration cases across Europe, and the aim of WP 2 is to assess the economic and environmental performance of different water technologies, to optimise the systems. This has been done by developing, customizing, and demonstrating tools.

The deliverable constitutes the re-design and stress test of NextGen selected case study systems using the two tools available in the NextGen toolbox, including the long-term performance of the solutions designed and modelled.

1.2. Intended readership

This deliverable is open to the public, but it is primarily intended for Consortium partners. It also may be of interest for other stakeholders interested in ICT tools for Water Circular Economy.

1.3. Relationship with other NextGen tasks/WPs

This deliverable builds on the results of the work performed in the task “Task 2.3 Re-design and stress test the system as a whole” using the two tools (the HydrOptim and the UWOT) to evaluate and optimize the hydraulic networks of the different demo cases:

- The Hydroptim is a key decision support system tool (DSS) for the optimization of the operation of hydraulic systems. It helps to increase efficiency while reducing operational expenditure and, at the same time, satisfy the water demand and respecting the physical constraints of the network. The tool helps then end user to reduce cost KPI (€) of the network, mainly coming from energy unit cost (€/MWh).
- The UWOT (Urban Water Optioneering Tool) is a simulation-based Decision Support System (DSS) of the metabolism modelling type. It is able to simulate the complete urban water cycle by modelling individual water uses and technologies/options for managing them and assessing their combined effects at multiple scales. It can star from the household level, and progressing up until the neighbourhood, regional and entire city level.

The tools also have relation with the result of “Task 2.4 NextGen Toolkit development”, as both are available at the Toolkit. The latest version is to be found under the site of Water Europe Marketplace (<https://mp.watereurope.eu/>).



Also, tools have been used in some of the locations of the demo cases of “WP1 Demonstrate Technologies & Systems for Water in the CE”: Hydroptim in Costa Brava Region (ES), and Westland Region (NL); UWOT in Athens (EL), Westland Region (NL), and Filton Airfield (UK)

1.4. Document’s structure

Being a technical report, the document is organized in seven chapters.

- Chapter 2 provides an overview of the tools used (HydrOptim and UWOT), the architecture and implementation aspects as well as the wireframe of the 1st version of the application.
- Chapter 3 to Chapter 7 describes the demo case selected for the HydrOptim application and for UWOT application, with their characteristics, and configurations.
- And, finally, the conclusions and the future works are provided in Chapter 8.



2. The tools

2.1. HydrOptim

HydrOptim is a key decision support system tool (DSS) for the optimization of the operation of hydraulic systems: increase efficiency and reduce operational expenditure related to energy, water sources, process treatment, etc. At the same time, the tool satisfies the water demand and respecting the physical constraints of the network.

HydrOptim helps the end user to reduce cost KPI (€) of the network, mainly coming from energy unit cost (€/MWh), providing an optimization of the operational decision-making of the water network (distribution, irrigation, ...), scheduling decision based on pre-defined water needs. Also, an environmental cost (€/m³) can be added to the different elements, and the tool will provide an optimization of the cost for the water network taking in account all the costs.

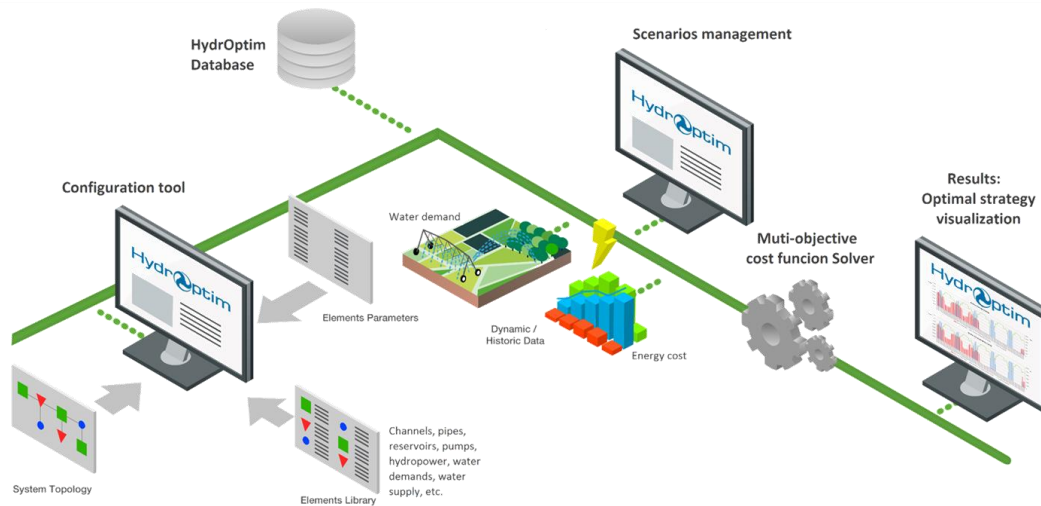

Figure 1 HydrOptim structure

Hydroptim tool is composed of in three different blocks, two of which have been implemented under the same user interface.

- The configuration tool includes the user interface for modelling of the hydraulic network, its scenarios and all the necessary parameterizations. It allows the user to access, to create, to define, and to update a network, with its different elements, to define the characteristics of each of the elements, and to create the different scenarios, for a defined model. Is through this interface from where the user can run the optimization and, of course, save, update, and check the data.
- The optimizer transforms the data of the selected model and scenario to the GAMS template, executes the optimization from the generated GAMS template, and transforms the GAMS output to models which we can persist in the database.



- The visualization tool, that creates and analyses of the report templates, and reviews the reports and make decisions

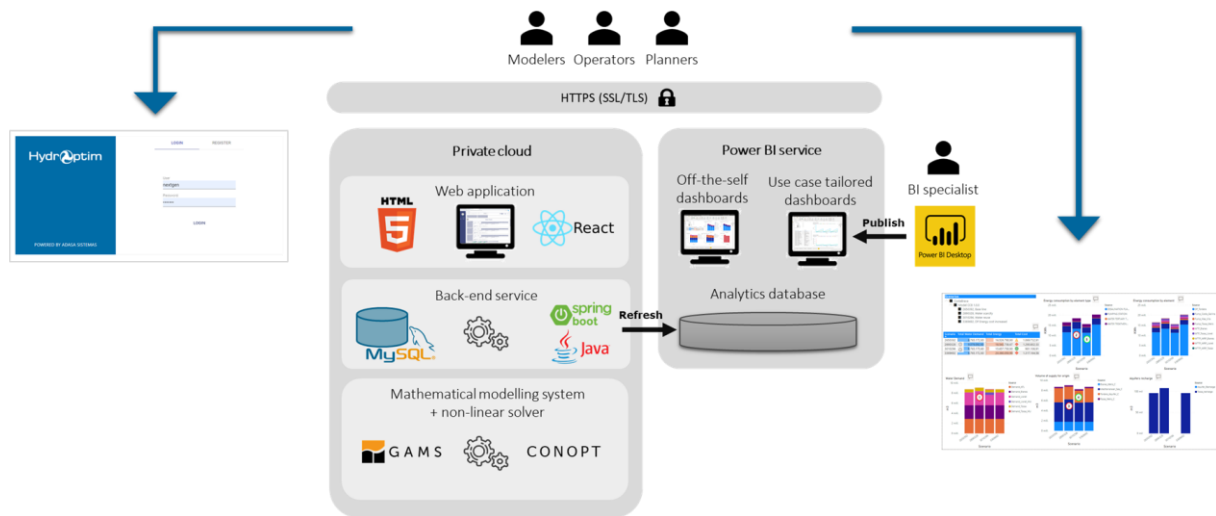

Figure 2 HydrOptim technical architecture

The principal Components of the system, as shown in Figure 3, are:

- Ngix Server. Hosts the User Interface of the system, The UI is developed with Reactjs Framework and helps the user to log into system, design the model, introduce the data, execute the scenario, and visualize the results.
- Embedded Tomcat Server. Hosts the Backend and business logic of the system, the Backend is developed with Spring Boot Java framework. The main functions of the backend are:
 - Modelization the data into the database
 - Transformation of the models/elements data into the mathematical template language to be processed and calculated by the mathematical modelling engine.
 - Expose an API to the UI and other clients (sensors, mobiles, ...)
 The backend is connected to the Ngix server by a proxy, for security is not exposed to the public access, can access only via VPN.
- Mathematical modelling system (non-linear solver). Is a third-party software, and it has its own language. The backend translates the scenario to input template to be executed by the engine, then transform the results according to the data model of the system.
- File System. Where the Backend generate the input template then the mathematical engine generates the output.
- Postgres Data Base. Where the user, scenarios data and results are stored.



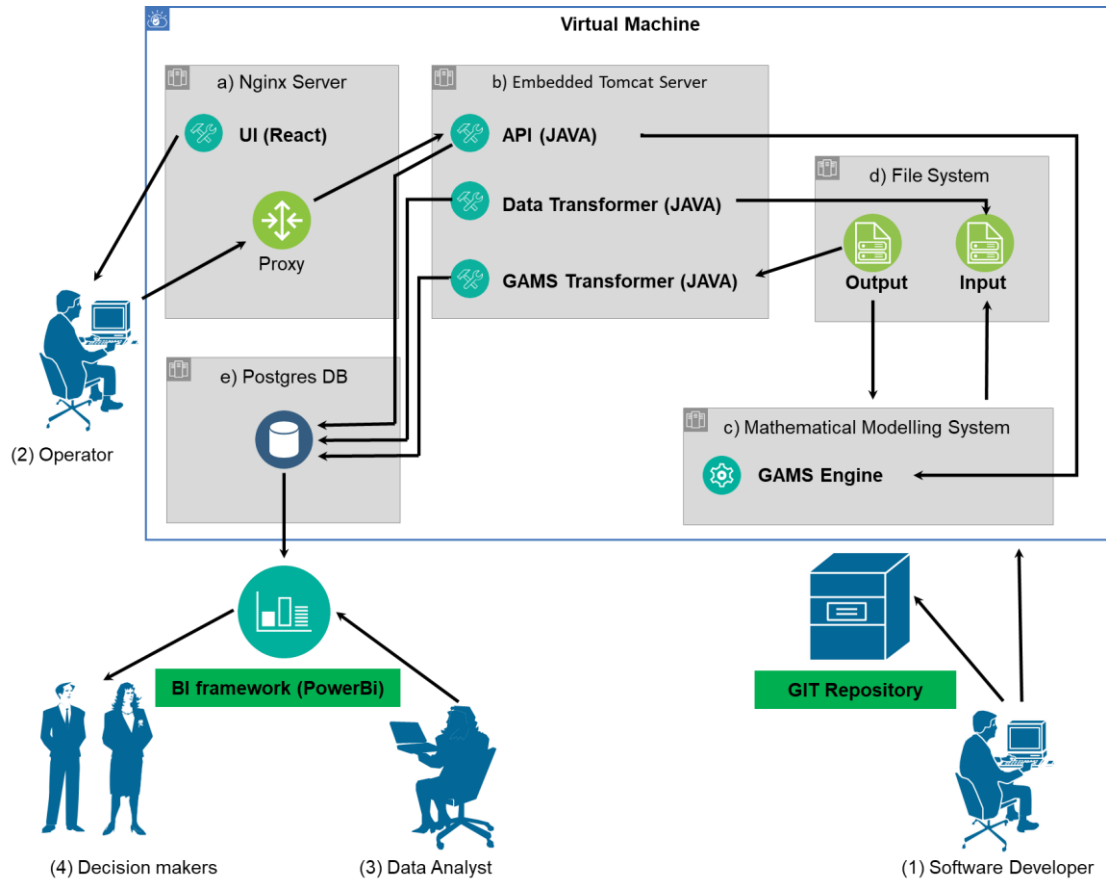

Figure 3 Hydroptim architecture



2.1.1. HydrOptim components

All components in a water network are represented through a topologic model which includes reservoirs, pipes, channels, pump stations, water inputs and outputs, and nodes.

2.1.1.1. Scenarios

A Scenario is a set of characteristics and configurations based on a possible situation, real or not, of a hydraulic model. A hydraulic model can have several linked scenarios, based on different assumptions or decisions, which allow analysing, forecasting and comparing past, present and future scenarios.

The Scenario properties are

- Name: Identifier of the scenario.
- Description: Brief explanation of the scenario.
- Creation date.
- Date of resolution.
- Infeasible: Number of infeasible warnings returned by the solver.
- Unbounded: Number of warnings out of limits returned by the solver.
- Errors: Number of errors returned by solver.
- Time horizon: Start and end date of the scenario.
- Duration of the optimization (hours): Total hours of duration of the scenario.
- Duration of optimization (days): Total days of duration of the scenario.

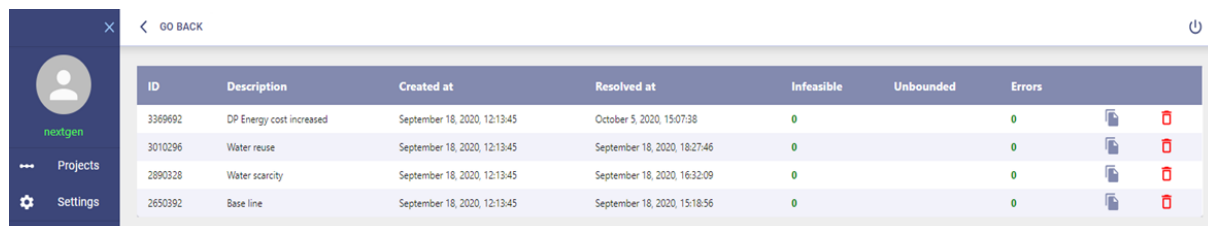

ID	Description	Created at	Resolved at	Infeasible	Unbounded	Errors
3369692	DP Energy cost increased	September 18, 2020, 12:13:45	October 5, 2020, 15:07:38	0	0	0
3010296	Water reuse	September 18, 2020, 12:13:45	September 18, 2020, 18:27:46	0	0	0
2890328	Water scarcity	September 18, 2020, 12:13:45	September 18, 2020, 16:32:09	0	0	0
2650392	Base line	September 18, 2020, 12:13:45	September 18, 2020, 15:18:56	0	0	0

Figure 4 Example of List of scenarios

2.1.1.2. Elements

The model of a hydraulic network consists of components, called elements. Each element type has certain properties.

The element types supported by HydrOptim, as well as their properties are described below:

- Reservoir: Water tank that stores water for future use
 - o Maximum volume: Maximum water capacity.
 - o Minimum volume: Minimum volume below with water abstraction is not possible
 - o Initial volume: Amount of water contained at the beginning of the period.
 - o Weight: Weighting of the reservoir within the objective function.
 - o Volume curve: Volume / height ratio.
- Water Input: Incoming water flow unit.
 - o Hourly flow: Flow of water that enters the system every hour.
- Water Source: Unit representing water volume that can enter the system in a specific period.



- Maximum volume: Maximum water capacity.
- Minimum volume: Minimum water capacity.
- Monthly volume: Maximum water capacity in that month.

- Pipeline: Water transmission channel.
 - Maximum flow: The discharge capacity of the pipe.
 - Delay: Number of hours that the water is traveling through the element.

- Pumping station: Unit that pumps water to a higher height.
 - Maximum flow: Maximum hourly flow of water that can be pumped.
 - Weight: Relative priority of the pumping station with respect to the rest.
 - Energy cost: Hourly energy price.
 - Energy / volume curve: Equation that relates the volume of water pumped with the energy cost involved.

- Water Treatment Plant: Unit that processes water by consuming energy.
 - Maximum flow: Maximum hourly flow of water that can be treated.
 - Minimum flow: Minimum hourly inflow that needed for the operation of the WTP..
 - Weight: Relative priority of the pumping station with respect to the rest.
 - Energy / volume curve: Equation that relates the volume of water treated with the energy cost involved.
 - Energy cost: Hourly energy price.
 - Leak: Percentage of water that is lost in the treatment process.
 - Environmental Cost: Calculation of the environmental impact of water treatment

- Hydroelectric Plant: Unit that generates electricity from water flow.
 - Maximum flow: Maximum hourly flow of water that can be treated.
 - Weight: Relative priority of the pumping station with respect to the rest.
 - Energy / volume curve: Equation that relates the volume of water that passes through the station with the value of the energy generated.
 - Energy value: Value of the energy generated each hour.

- Water Demand: Unit representing water requested from the consuming elements.
 - Weight: Relative priority of demand with respect to the rest.
 - Efficiency: Percentage of incoming water that leaves the element after being consumed.
 - Demand Type: Can be Daily Demand that uses daily values, Demand With Pattern that uses hourly values, or Periodic Demand that uses monthly values.
 - Daily: Volume of water that the element needs each day of the optimization time horizon.
 - Pattern: Volume of water that the element needs each hour of the optimization time horizon.
 - Periodic: Combine the volume of water that element needs at the end of the optimization time horizon with the daily volume of water

- Water Output: Water outflow from the network.
 - Hourly flow: Flow of water that leaves the system every hour.



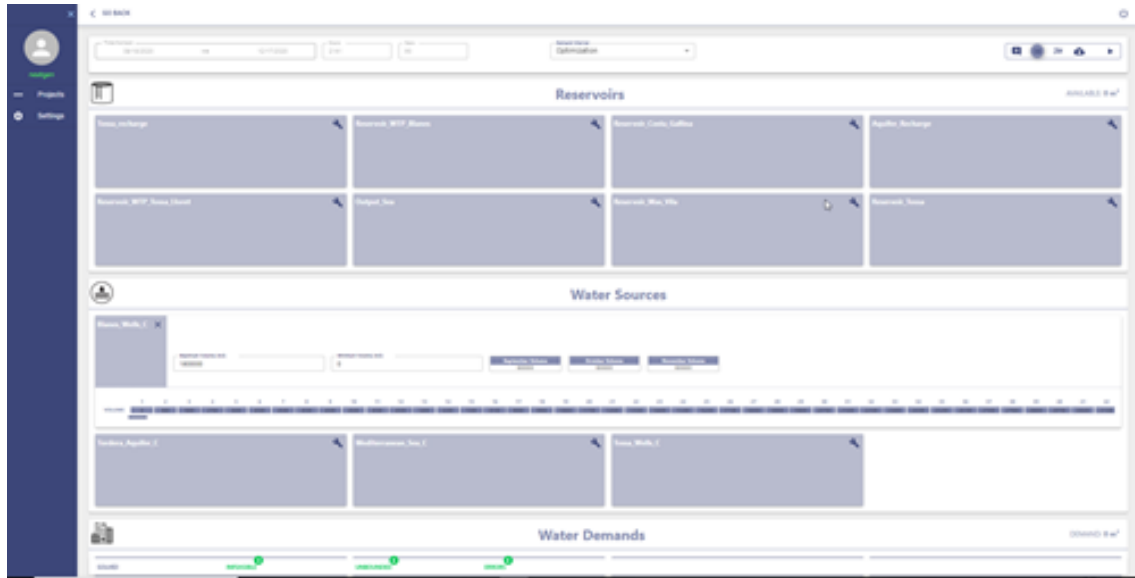

Figure 5 Example of definition of elements

2.2. UWOT

UWOT is a simulation-based Decision Support System (DSS), of the metabolism modelling type, able to simulate the complete urban water cycle by modelling individual water uses and technologies/options for managing them and assessing their combined effects at multiple scales, starting from the household level and progressing up to the neighbourhood, regional and entire city level (Makropoulos, 2017). UWOT follows a bottom-up, signal-based systems analysis approach that starts from individual components (i.e. in-house appliances, units that use water and generate wastewater or runoff) and proceeds to the generation, transmission, aggregation and transformation of water demand signals that start from the household level and propagate towards the source of water demands, i.e. the central drinking water network (Rozos & Makropoulos, 2013). This demand-oriented conceptualization (see also Figure 6) places household and neighbourhood demand as the starting point of every study and enables UWOT to simulate the whole urban water system from tap to source (Rozos and Makropoulos, 2013). UWOT is able to simulate both standard urban water flows, i.e. potable water, wastewater and runoff, modelled as signals, as well as integrated interventions at household and neighbourhood level, which target these flows in order to create feedback loops that cover household demand; other types of flows that can be modelled through appropriate components are green roofs, blue-green urban areas (Rozos et al., 2013), peri-urban areas, irrigated zones, generic pervious or impervious areas etc.

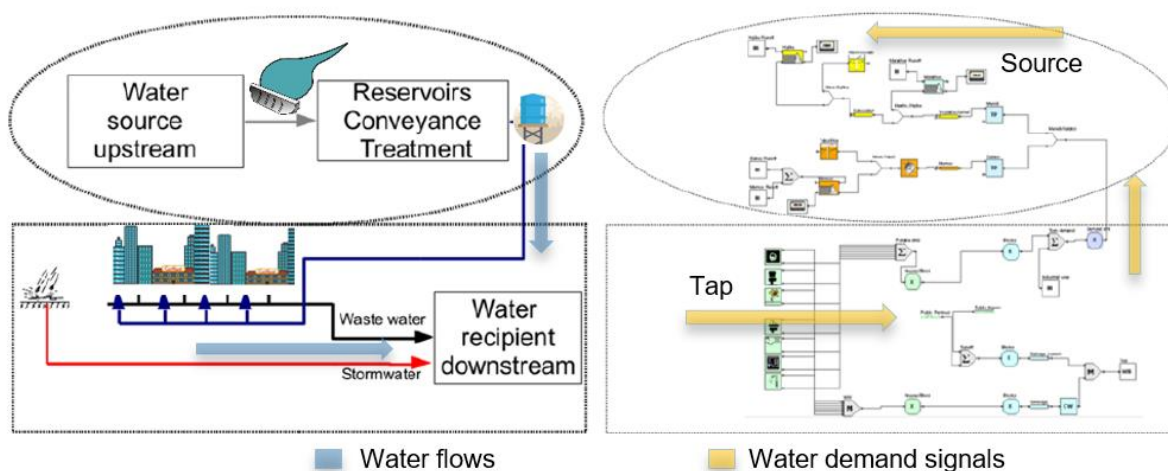

Figure 6 Modeling the urban water cycle from tap to source using UWOT (adapted from Makropoulos C. (2017))

UWOT has seen extensive use in water cycle modelling applications on different spatial scales for a range of different cases and demonstrated water management technologies. The range of applications includes neighbourhood-scale blue-green area design (Rozos et al., 2013), whole city cycle modelling (Rozos & Makropoulos, 2013), analyses of distributed neighbourhood options under scenarios of urban growth (Bouziotas et al., 2014), resilience studies (Makropoulos et al., 2018) and consultancy for circular water neighbourhood (re-) designs (Bouziotas et al., 2019).

3. The Costa Brava demo case (Hydroptim)

The proposed demo case for this study is a model of south Costa Brava, an area on the north coast east of Catalonia in Spain.

The objectives of Costa Brava CS are the followings:

- To model the supply network of three municipalities: Blanes, Lloret de Mar and Tossa de Mar.
- To cover all the demands from the available water sources, and at the same time to optimize the energy and the environmental costs.
- To let the user to observe from which source the water has been taken at each moment, while Hydroptim ensures that the demands are covered at the lowest possible cost.

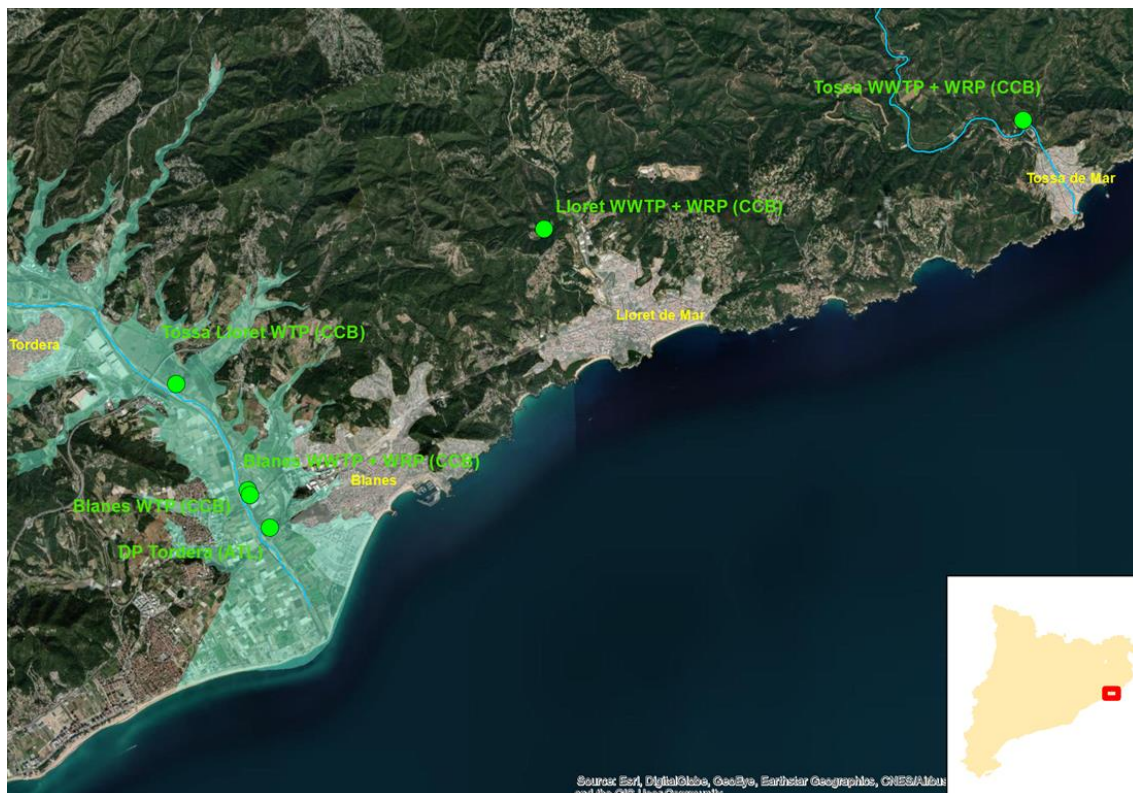

Figure 7 Map of Costa Brava demo case

The main characteristics of the system are:

- The water is extracted from the aquifer and the Mediterranean Sea.
- The extracted water must be desalinated (in the case of sea water) or purified (in the case of aquifer water) in treatment plants, resulting to energy costs.
- The water must be stored and transported from the point of origin to the point of consumption. This requires the use of pumping stations that incurs in energy expenses.
- The water is consumed in the villages.



- Wastewater is treatment in nearby water treatment plants, and reused water is used for environmental uses.

3.1. The model for Costa Brava

Figure 8 shows the model of the water network supply to three main urban areas represented by the demands of Tossa, Lloret de Mar and Blanes. Another node represents the demand of an external water network (ATL network).

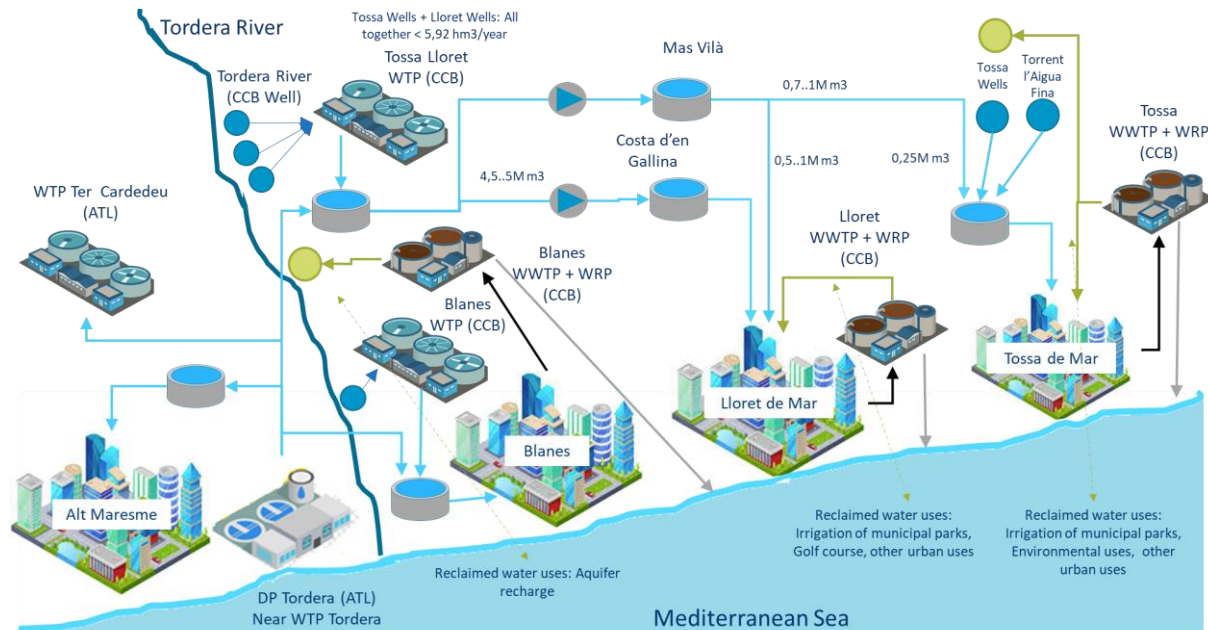

Figure 8 Hydraulic model for Costa Brava demo case

To supply these demands there are three different water sources, each with its associated energy costs.

- The Tordera aquifer, the Mediterranean Sea, and some wells (Tossa and Lloret de Mar).
- The main sources are the Mediterranean Sea and the aquifer.
- The Mediterranean Sea is the most expensive water supply, in energy terms, because of the desalination process, but it is an unlimited water source. On the other hand, the aquifer is a clean water source, but it has some limitations such as limited available volume of water (and a variable volume depending on the meteorological conditions, ecological restrictions, month of the year, etc.).
- Wells provide also clean and good quality water, but extracting water from them comes with an extra cost that should be avoided as much as possible.

We can distinguish two different types of water demands: the usual urban demand, and the environmental demand, that can be consider as a percentage part of the urban demand. This environmental demand should be as high as possible, but if it is too high, additional costs will be required to meet it. However, if it is small enough it can be satisfied with the recycled output water from the usual urban demand.



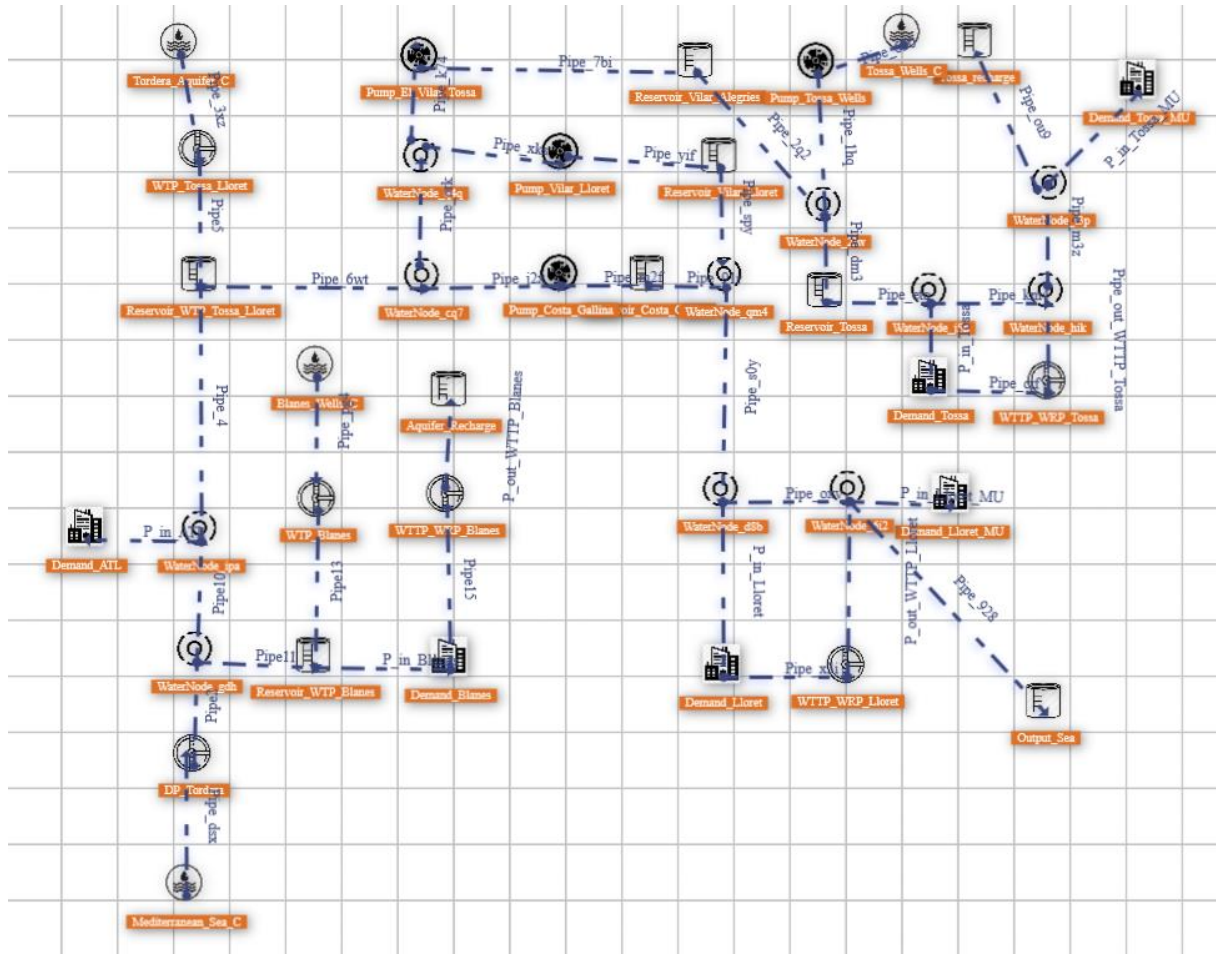

Figure 9 Model of Costa Brava demo case (Screen copy from HydrOptim tool)

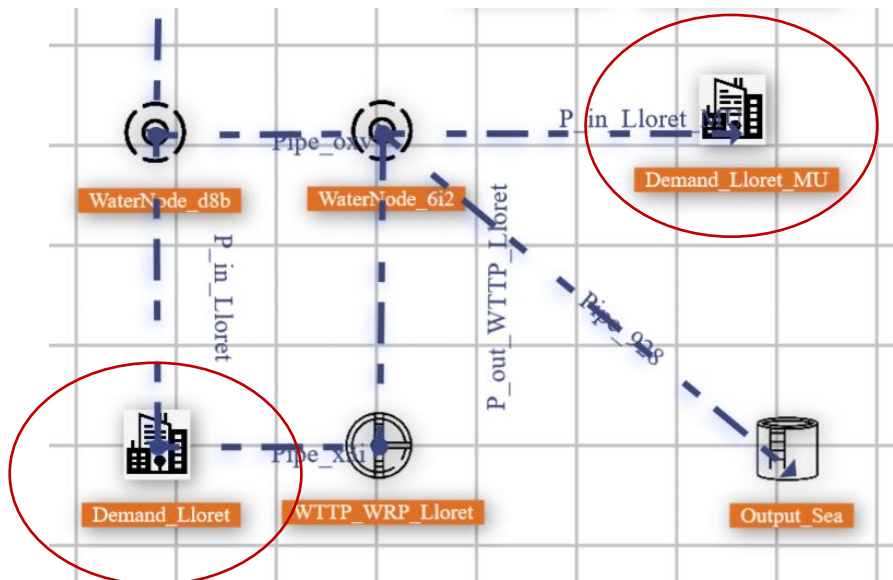

Figure 10 Detail of water demand elements of Costa Brava demo case (Screen copy from HydrOptim tool)



The main concerns about the model of Costa Brava is that the demand of the cities has been split in two different parts, as shown in Figure 10: one part is the amount of water that must have potable water quality, and the other party is the water that can have potable or reclaimed water quality.

3.1.1. Elements of the Model

To represent the Costa Brava water supply network, five main types of elements have been used, that are listed below.

- Water sources represent the available input water to the system.
- Reservoirs store the water to provide stable amount of water downstream.
- demands model the consumption of the network.
- Water Treatment Plants model some specific treatments such is desalinization of the sea water
- Pumps.

The specific parameters of each element in the Costa Brava model are shown in Table 1

Table 1 Maximum Water abstraction per source in the Costa Brava demo case

Source	Maximum Volume (m ³ /3 months)	June Volume (m ³ /month)	July Volume (m ³ /month)	August Volume (m ³ /month)
Tordera Aquifer	2,790,000	930,000	930,000	930,000
Mediterranean Sea	9,000,000	300,000	300,000	300,000
Blanes Wells	1,800,000	600,000	600,000	600,000
TossaWells	0	0	0	0

In Table 1 we can see the maximum available volume of the water sources distributed in three months. In the case of the Tordera Aquifer, the values correspond to the Normality Scenario. In the case of the Mediterranean Sea, the values are high enough to represent and endless water source

Table 2 Reservoirs of Costa Brava demo case

Reservoir	Maximum Volume (m ³)
WTP Tossa Lloret	10,000
WTP Blanes	100,000
Vilar Alegries	5,500
Tossa	10,000
Vilar Lloret	1,000
Costa Gallina	25,000

Table 2 is the total capacity of the different reservoirs of the network.

Table 3 Water demands of Costa Brava demo case

Demands	Total Demand (m ³)	Efficiency
Blanes	2,700,000	1



ATL	2,879,262	1
Tossa	483,065	0.8
Tossa MU	23,400	0
Lloret	2,221,377	0.8
Lloret MU	23,400	1

The different water demands are modelled as a required volume in a certain time (3 months for this case). In this case, it is the total volume in the period of the scenarios. In this case, it is the total volume in the period of the scenarios. The efficiency parameter represents the capacity of the system to reuse the leftover water of the demand. If the value is 1 it means there is no water to reuse.

Table 4 Water Treatment Plants of Costa Brava demo case

WTP	Maximum Flow (m ³ / h)	Energy Cost (€/kWh)	Leak
Tossa Lloret	0.41	1	1
DP Tordera	0.67	1	1
Blanes	0.25	1	1
WRP Blanes	0.13	1	1
WRP Tossa	0.05	1	1
WRP Lloret	0.21	1	1

The Water Treatment Plants have a maximum capacity and an associated cost to work. There is as well a possibility to model leaks in this element as a way to model an efficiency. In this case the 1 value means that has no effect the calculations (neutral element for the multiplication).

Table 5 Pumps of Costa Brava demo case

Pump	Maximum Flow (m ³ /h)	Energy Cost (€/kWh)
El Vilar Tossa	0.1	1
Tossa Wells	0.05	1
Vilar Lloret	0.1	1
Costa Gallina	0.41	1

Finally, the pumps are characterized by a maximum capacity of flow to pump and an associated cost.



3.1.2. Initial Scenarios

To study how we can satisfy all the specified demands in the network depending on different environment situations several Scenarios have been set. In all of them, the system must satisfy the demands, but the main goal is how to do while optimizing the energy cost for the available sources.

The differences between scenarios are in the availability of fresh water from the aquifer (Table 6). This source depends on the accumulated water during the year. In addition to this weather dependency there is a minimum ecological volume that must be assured. When the available water from the aquifer is not enough to satisfy all the demands on the network the system will take water from the Mediterranean Sea source with will increase the associated cost.

The different scenarios range from a situation of a *Normality* (the Base Line scenario), that is when the aquifer is running at its full capacity, to an *Emergency* situation were the aquifer cannot fully satisfy all the expected demands. The Scenarios are described below as the available volume of water per month for a three-month period.

Table 6 Water availability from aquifer for Scenarios for Costa Brava demo case

	Scenario	June (m ³)	July (m ³)	August (m ³)	TOTAL (m ³)
	Normality	930,000	930,000	930,000	2,790,000
Real	Alarm	582,841	771,164	831,909	2,185,914
	Exceptionality	536,213	709,470	765,356	2,011,039
	Emergency I	466,272	616,931	665,527	1,748,730
	Emergency II	419,645	555,238	598,974	1,573,857
	Emergency III	373,017	493,545	532,421	1,398,983

To understand the results is important to note how the water is managed and distributed in the network.

- The Costa Brava network have two main branches: The Tossa-Lloret branch and the Blanes branch.
- The Tossa-Lloret branch is mainly supplied by the aquifer source while the Blanes branch is supplied by the Blanes wells and the Mediterranean Sea sources.

In the Normality Scenario both sources, aquifer and sea, supply each branch respectively. So, in the case of the restricted scenarios the branch that is mainly affected is the Tossa-Lloret and it is the one that we should supply with the extra water from the sea.

The first thing to consider in each case is how much water we have and how much water we need to supply the demands. This information is shown in Figure 11 and Figure 12. What we can see is that in the Normality scenario there is enough water from the aquifer to supply the entire volume of demands, while the other scenarios do not reach the total demand level. Therefore, apart from the Normality scenario, all other scenarios must take water from the sea to satisfy the total demand, increasing the total energy consumption.



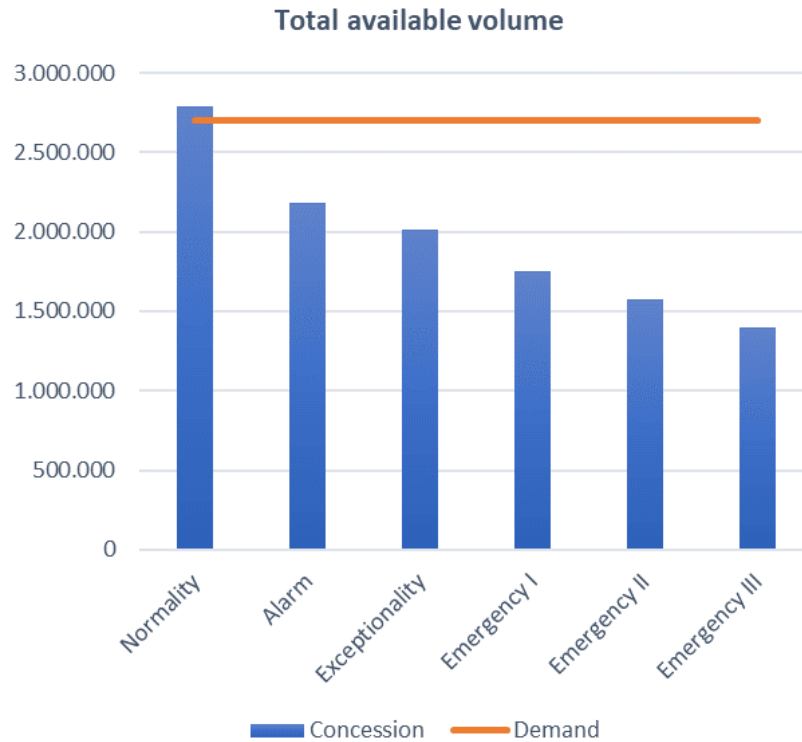

Figure 11 Available volume (m³) from aquifer

To better understand the problem, it is important to consider additional supply restrictions, such as the distribution of the aquifer’s available water volume during the studied months. As we can see in Figure 12, in the Normality scenario a constant amount of water is available during the whole period, but the rest of the scenarios are more restrictive in the first month than in the other two months. That means that management of the aquifer supply should be different depending on the period of the scenario according to these situations.

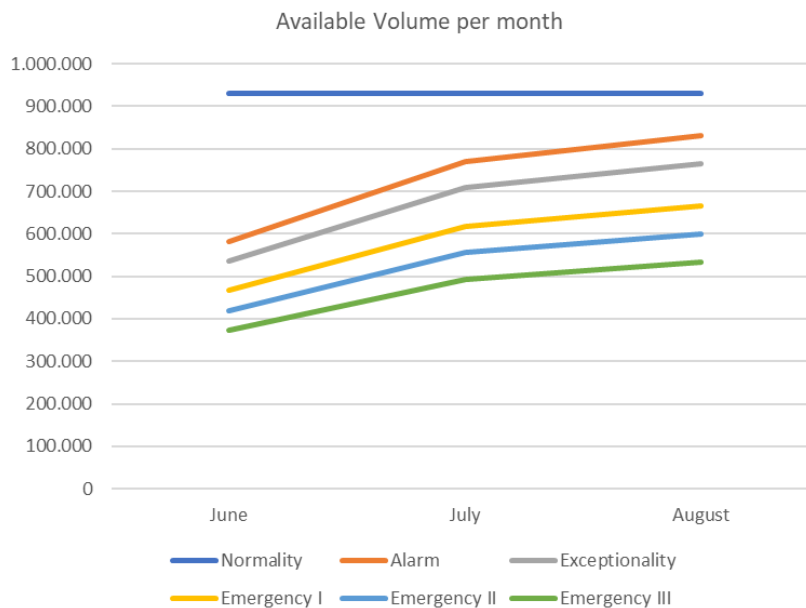

Figure 12 Available volume (m³) per month



The effect of this lack of water from the aquifer is that the global energy consumption increases correspondingly since the rest of the needed water is taken from the Mediterranean Sea and the desalination process adds an extra cost.

Table 7 and Figure 13 illustrate how the total amount of energy consumed rises as aquifer water becomes scarcer and more seawater is extracted

Table 7 Water supplied from aquifer and energy consumed

Scenario	Concession (m ³ / 3 month)	Concession %	Total energy Consumption (kW)	Total energy Consumption %
Normality	2,790,000	100%	1,580,3197.64	100.00%
Alarm	2,185,914	78.35%	1,716,8520.04	108.64%
Exceptionality	2,011,039	72.08%	1,763,1938.79	111.57%
Emergency I	1,748,730	62.68%	1,832,7057.64	115.97%
Emergency II	1,573,857	56.41%	1,879,0471.09	118.90%
Emergency III	1,398,983	50.14%	1,925,3887.19	121.84%

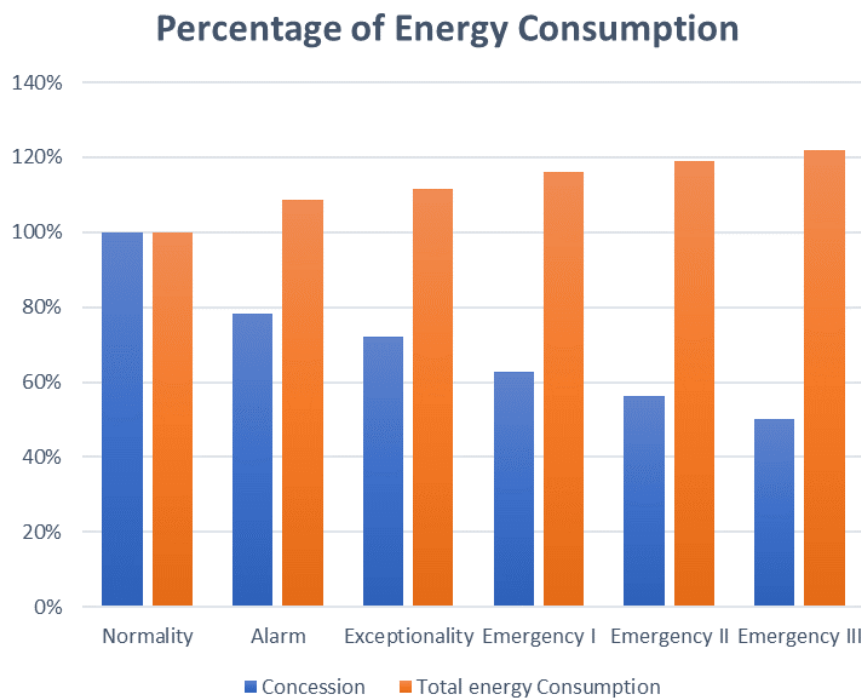

Figure 13 Total Energy consumed

As shown in the Figure 13, as the water abstraction from the aquifer decreases, energy consumption increases proportionally in terms of percentage.



3.2. Results of Initial Scenario

The selected scenarios in the Costa Brava Model describe different critical situations regarding the availability of the water volume from the Aquifer source. In those situations, where the amount of water is not enough to satisfy the demands the system will take the needed water from other sources despite the cost increases.

In this section we will show how the system manage these situations by comparing the different results. The selected scenarios for this comparison are the Real Scenarios described in Section 3. In both cases we have the Normality, Alarm, Exceptionality, Emergency I, Emergency II, and Emergency III scenario.

As explained in Section 3, the Costa Brava network have two main branches: The Tossa-Lloret branch that it is mainly supplied by the aquifer source, and the Blanes branch, that it is supplied by the Blanes wells and the Mediterranean Sea sources.

3.2.1. Volume of supply

While the total water demand remains constant, the distribution of the water supply between the available sources depends on the scenario. In the *Normality* scenario, the amount of sea water is about 45% while the water abstracted from the aquifer is about 32% of the total needs. This difference increases a soon as we have problems to extract water from the aquifer as we can see in the figure below. As critical the scenario is, the more seawater is required.

Table 8 Distribution of water supplied in Real Scenarios

Scenario	Blanes Wells	Mediterranean Sea	Tordera Aquifer	Tossa Wells
Normality	21.8%	45.6%	32.6%	0.0%
Alarm	21.8%	51.8%	26.4%	0.0%
Exceptionality	21.8%	53.9%	24.3%	0.0%
Emergency I	21.8%	57.1%	21.1%	0.0%
Emergency II	21.8%	59.2%	19.0%	0.0%
Emergency III	21.8%	61.3%	16.9%	0.0%

In Table 8 and Figure 22 we can see the water needs under the different scenarios. It is clear the balance between the Mediterranean Sea and the aquifer: for total volume, if percentage from aquifer decreases, the percentage from seawater increases.



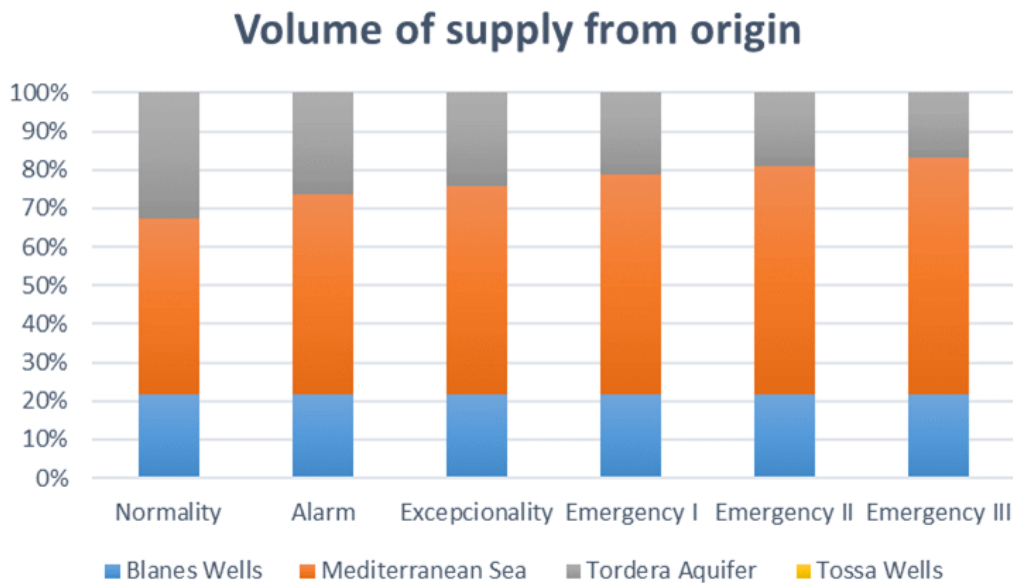

Figure 14 Distribution of water supplied in Real Scenarios

3.2.2. Total Energy

The energy consumption reflects the distribution of water supply by source. When we extract water from the sea, we have to apply a process of desalinization (including other side effects such as pumping the water). That means we need more energy to satisfy the demands as it is shown in Figure 15.

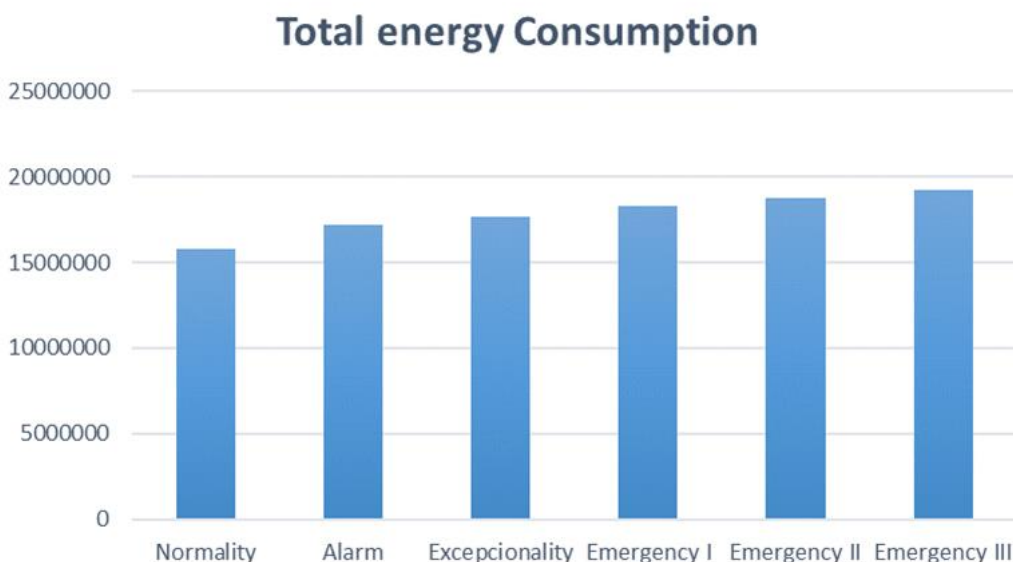

Figure 15 Total energy consumption (€) in Real Scenarios

As we can see, The Normality scenario is the cheapest case in terms of the energy consumption due the fact that the branch of Tossa-Lloret is exclusively supplied by the aquifer source. The other scenarios need to combine the aquifer source and the Mediterranean Sea to reach the demand level of the Tossa-Lloret branch.



3.2.3. Energy consumption by type

If we break down the total consumption, we can examine the different types of elements and how this affect energy consumption. Figure 16 shows the aggregated energy consumption by element type. From this graph, one can easily identify the desalination process as the main cause of energy consumption in the water distribution network. While other processes show relatively constant energy needs, in case of the desalination plants, energy consumption depends strongly on the selected scenario. A small difference in energy consumption of the Water Treatment Plant is because the WTP Tossa Lloret must treat a smaller volume of water.

Table 9 Distribution of Energy consumption by type in Real Scenarios

Scenario	Other	Desalination Plant	Pumping Station	Tertiary Treatment Plant	Water Treatment plant
Normality	14.1%	71.7%	3.1%	1.2%	10.0%
Alarm	12.9%	75.0%	2.8%	1.1%	8.1%
Exceptionality	12.6%	76.0%	2.7%	1.1%	7.6%
Emergency I	12.1%	77.4%	2.6%	1.0%	6.8%
Emergency II	11.8%	78.3%	2.6%	1.0%	6.3%
Emergency III	11.5%	79.1%	2.5%	1.0%	5.8%

This table shows the percentage of energy consumed with respect to the total energy consumed in each scenario.

Energy consumption by element type

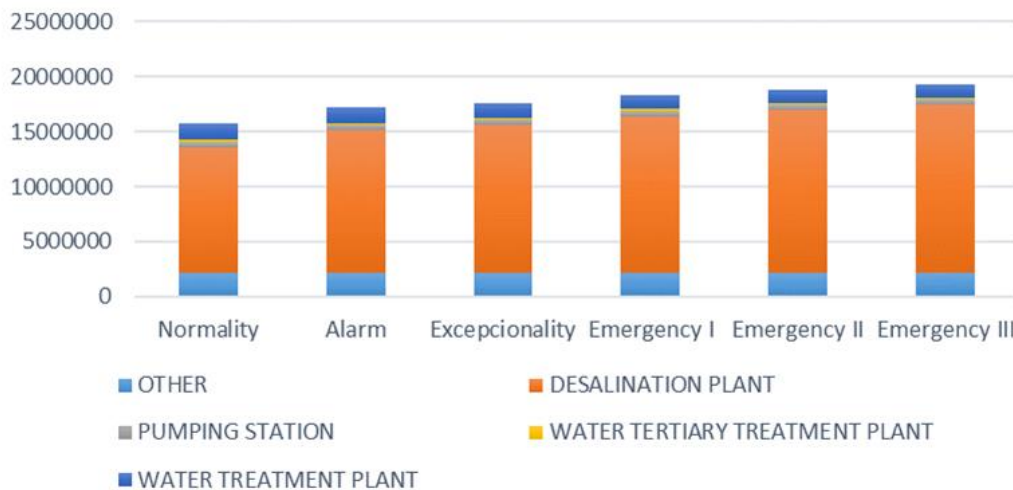

Figure 16 Energy consumption (€) by element type in Real Scenarios

The desalination plant, as we can see in the previous figure, is the element that increases the most. In this figure is important to note that the desalination plant includes the normal desalination consumption energy needed for the Blanes branch plus the extra effort to reach the demand level of the Tossa-Lloret that cannot be reached by the aquifer alone.



3.2.4. Energy consumption by element

Going even deeper, as we look at the single elements of the network, we identify, as we expected, the Desalination Plant of Tordera (DP Tordera) as the one with the greatest increase in energy consumption as the scenarios become more critical, while the WTP Tossa Lloret has lower energy needs due to the lower volume to treat. This observation is consistent with previous results.

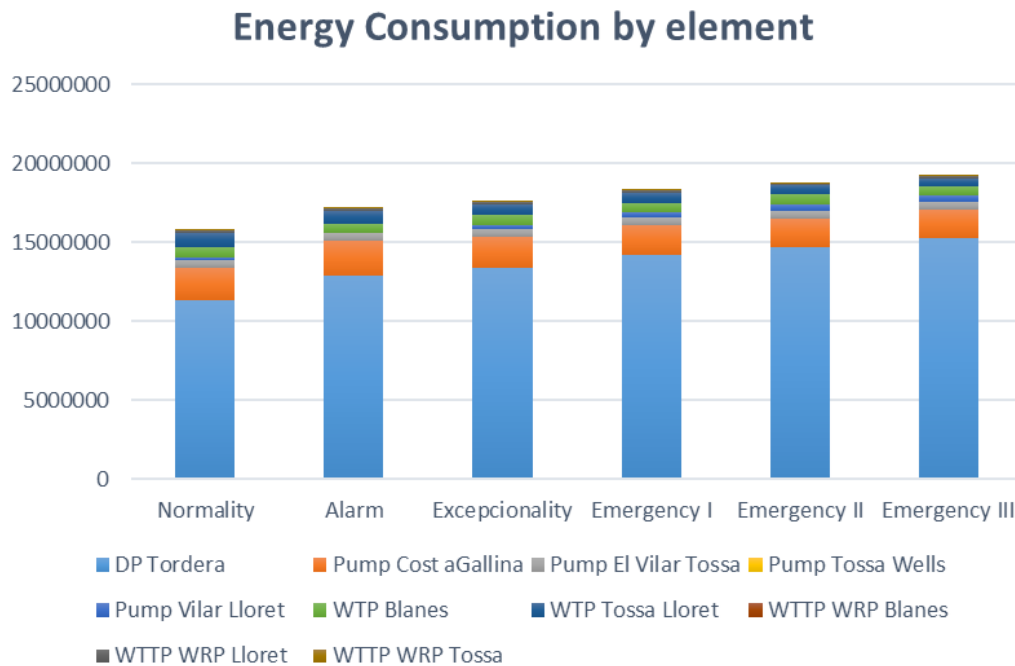

Figure 17 Energy consumption by different element in different Scenarios

If we look at the increment of the energy in the desalination plant and the WTP Tossa Lloret elements, that are the ones that are affected by the restrictions in the source of the aquifer, we can see how much this increase is.

Table 10 Energy consumption by element in Real Scenarios

Scenario	DP Tordera	WTP Tossa Lloret
Alarm	13.6%	-19%
Exceptionality	18.3%	-26%
Emergency I	25.2%	-35%
Emergency II	29.8%	-42%
Emergency III	34.5%	-48%

In this table we see the variation in the effort at the desalination plant and WWTP to supply water because of the lack of water in the aquifer respect the Normality scenario.



3.3. The stress testing

For the Costa Brava demo case, the stress test has been applied for the added scenarios defined by the Consorci Costa Brava, as end user of the system, with a reduction of the water that can be supply from the aquifer because of the requirements of reduction of extraction of underground water.

3.3.1. Volume of supply in Stress test

In addition to the initial scenarios, 5 more scenarios have been proposed with different restrictions on the available water in the aquifer. As in the initial scenario, the amount of needed water to supply the demands in the network comes from the aquifer when it is possible and from the Mediterranean Sea when the water of the aquifer is not enough. While the amount of the total demand is constant, the distribution of the water between the available sources depends on the scenario. In the Normality scenario, the water from the sea is about 45% while the water from the aquifer is about 32%. These differences increase a soon as we have problems to extract water from the aquifer as we can see in the Figure 18. The amount of water drawn from the sea increases as the scenario becomes more critical.

Table 11 Volume of supply in Stress testing Scenarios

Scenario	Blanes Wells	Mediterranean Sea	Tordera Aquifer	Tordera Aquifer	Tossa Wells
Normality	21.8%	45.6%	32.6%	32.6%	0.0%
Alarm	21.8%	47.1%	31.1%	31.1%	0.0%
Exceptionality	21.8%	48.0%	30.3%	30.3%	0.0%
Emergency I	21.8%	52.3%	26.0%	26.0%	0.0%
Emergency II	21.8%	54.8%	23.5%	23.5%	0.0%
Emergency III	21.8%	57.3%	21.0%	21.0%	0.0%

In Table 11 and Figure 18 we can see the evolution of the volume of water on the different scenarios. It is clear the mass balance between the Mediterranean Sea and the Aquifer. The percentages are taken respect the total volume of each scenario.



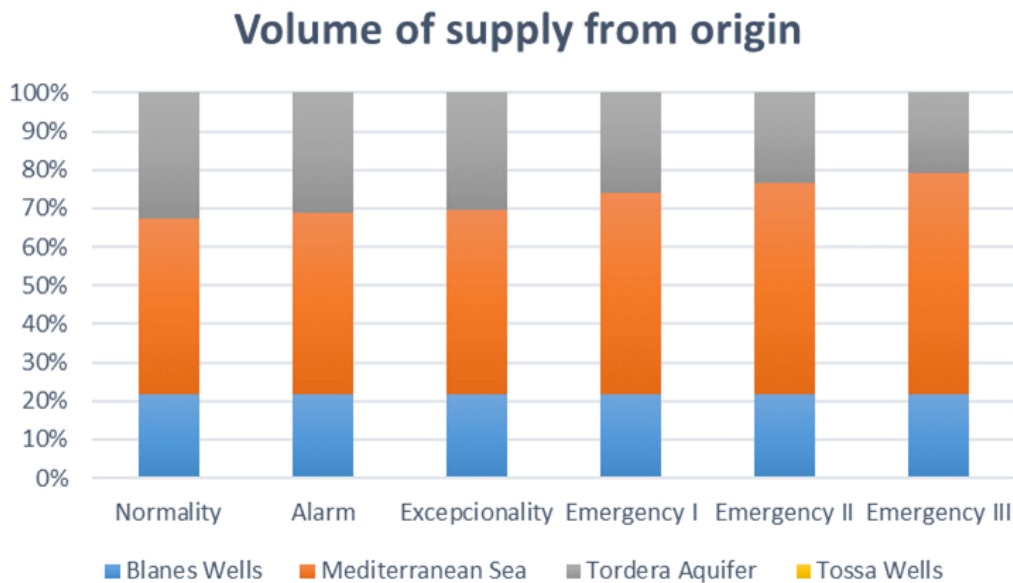

Figure 18 Volume of supply in Stress testing Scenarios

3.3.2. Total Energy in Stress Test

According to the effects of the volume we have the energy consumption. When we extract water from the sea we have to apply a process of desalinization (and other side effects such is pumping the water). That means we need more energy to satisfy the demands as it is shown in Figure 19.

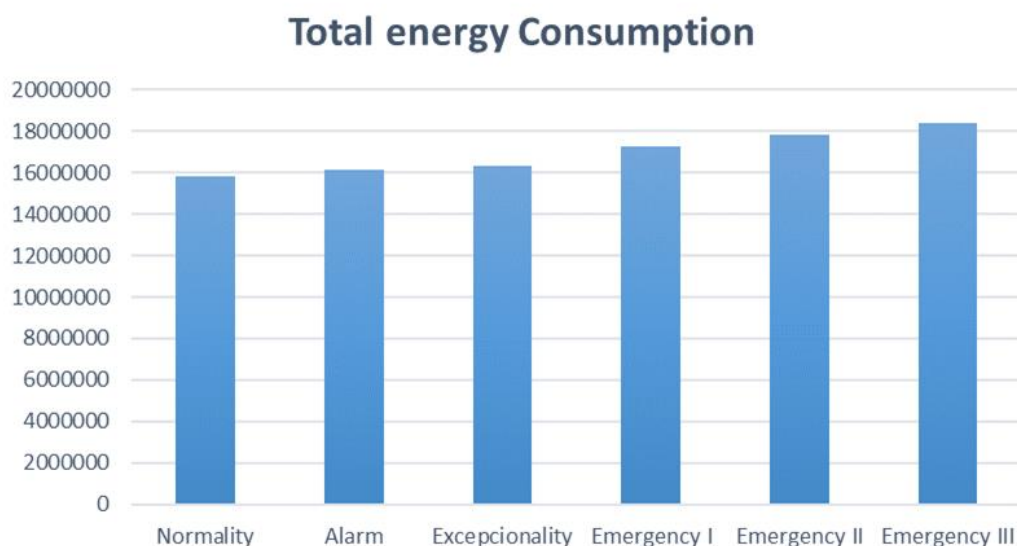

Figure 19 Total energy consumption (€) by element in Stress testing Scenarios

As we can see, The Normality scenario is the cheapest case in terms of the energy consumption due the fact that the branch of Tossa-Lloret is exclusively supplied by the aquifer source. The rest of the scenarios need to combine the aquifer source and the Mediterranean Sea to reach the demand level of the Tossa-Lloret branch.



3.3.3. Energy consumption by type in Stress test

If we go deeper in the total consumption, we can look at the different type of elements. In the next figure there are aggregated all the elements in its single type. So, in the network we can see that the main difference between each scenario is the desalination process. There is as well a little difference in the Water Treatment Plant due to the fact that the WTP Tossa Lloret has to treat less amount of water.

Table 12 Energy consumption by type in Stress Testing Scenarios

Scenario	Other	Desalination Plant	Pumping Station	Tertiary Treatment Plant	Water Treatment Plant
Normality	14.1%	71.7%	3.1%	1.2%	10.0%
Alarm	13.8%	72.6%	3.0%	1.2%	9.5%
Exceptionality	13.6%	73.0%	3.0%	1.2%	9.2%
Emergency I	12.9%	75.2%	2.8%	1.1%	8.0%
Emergency II	12.5%	76.4%	2.7%	1.1%	7.4%
Emergency III	12.1%	77.5%	2.6%	1.0%	6.7%

Table 12 and Figure 20 shows the percentage of energy consumed respect the total energy consumed in each scenario.

Energy consumption by element type

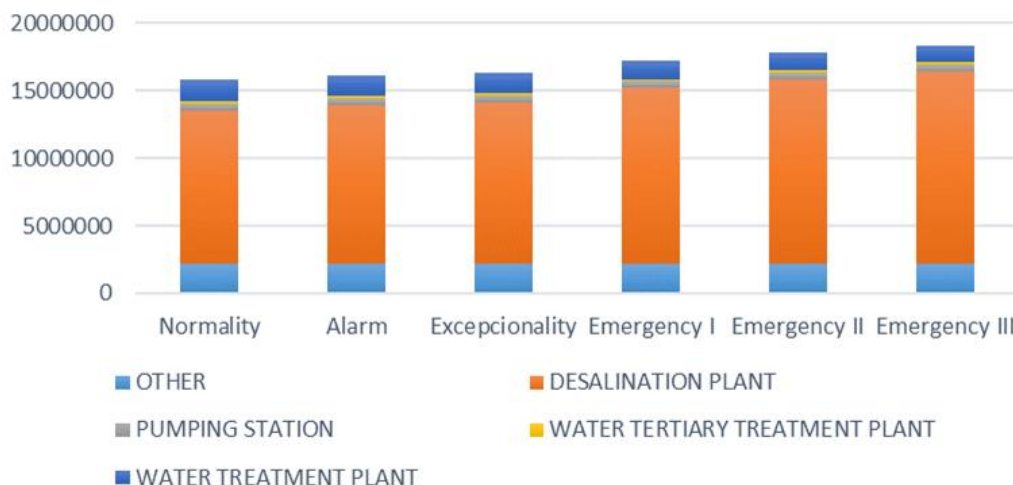

Figure 20 Energy consumption (€) by element in Stress testing Scenarios

The desalination plant, as we can see in the previous figure, is the element that increases the most. In this figure is important to note that the desalination plant includes the normal desalination consumption energy needed for the Blanes branch plus the extra effort to reach the demand level of the Tossa-Lloret that cannot be reached by the aquifer alone.



3.3.4. Energy consumption by element in Stress test

Going even deeper, we can look at the single elements of the network that consume energy, and we notice that the DP Tordera (Mediterranean Sea) is the one with the maximum increment as we expected while the WTP Tossa Lloret decreases due to the less volume to treat.

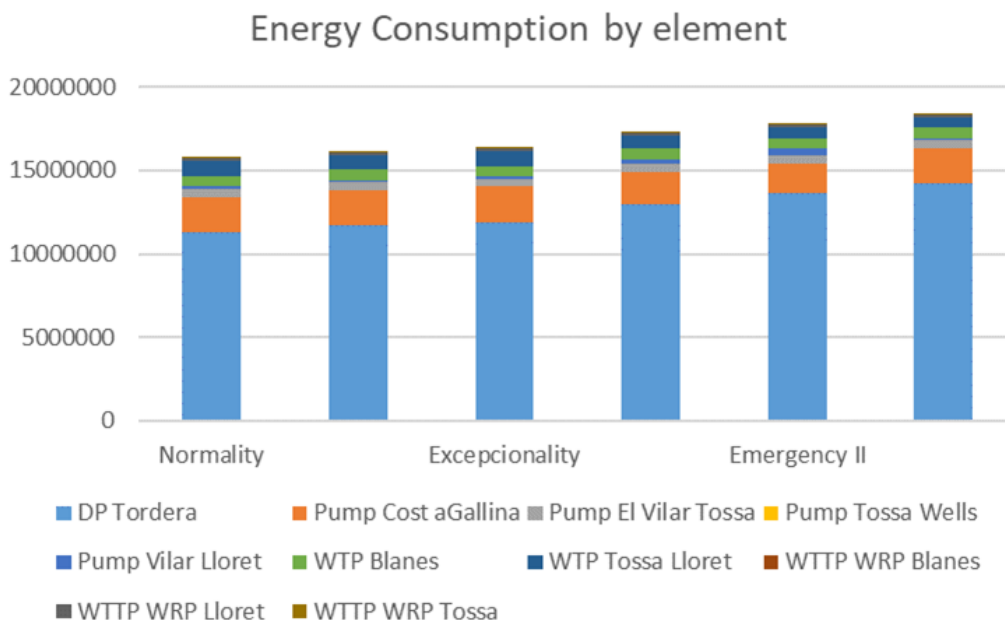

Figure 21 Energy consumption (€) by element in Stress testing Scenarios

If we look at the increment of the energy in the desalination plant and the WTP Tossa Lloret elements, that are the ones that are affected by the restrictions in the source of the aquifer, we can see how much this increase is.

Table 13 Energy consumption variation by element in Stress testing Scenarios

Scenario	DP Tordera	WTP Tossa Lloret
Alarm	3.3%	-4.6%
Exceptionality	5.2%	-7.3%
Emergency I	14.6%	-20.4%
Emergency II	20.1%	-28.1%
Emergency III	25.6%	-35.8%

In this table we see how much effort the desalination plant has done to supply the lack of water in the aquifer respect the Normality scenario.



4. The Delfland demo case (Hydroptim)

The proposed demo case for this study is a model of Delfland, a large zone at the Westland region in the province of South Holland in the Netherlands, that features multiple water uses:

- Total area of 405 km²
- 1.2 M households
- Mixture of urban (residential, commercial industrial) and rural (horticulture) areas.

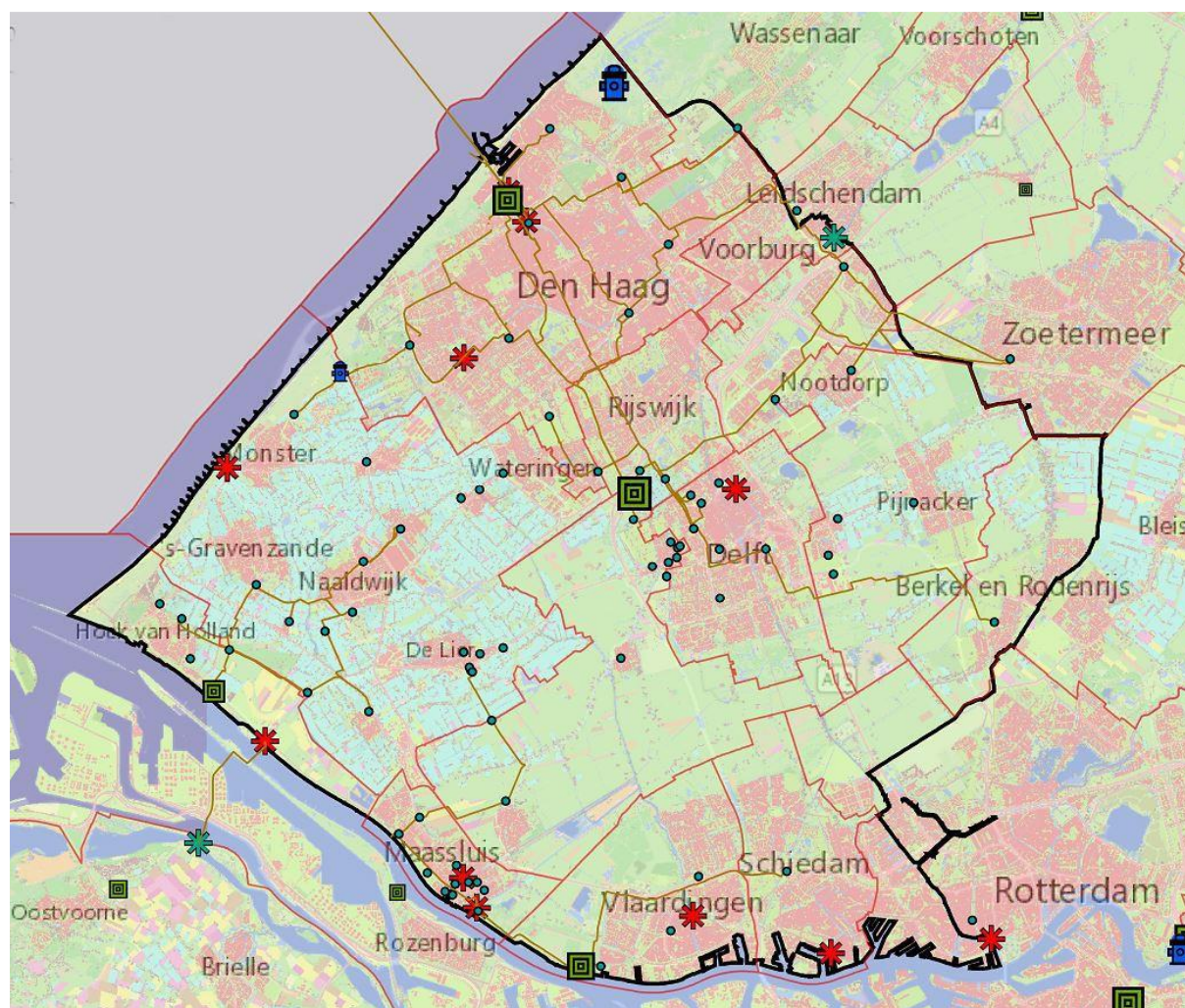

Figure 22 Map of Delfland demo case

Information available for the Delfland demo case are:

- Household consumption (water appliance uses and frequencies of use)
- Number of households, residential distribution (houses/apartments)
- Rainfall (daily time-series)
- Spatial characteristics of urban areas (pervious/impervious) Land use
- Treatment capacity and storage of typical decentralized urban systems (RWH/GWR) at neighborhood level
- Spatial characteristics of rural areas
- Number of greenhouses
- Greenhouse demands (daily time-series)



- Scenarios on greenhouse management (ASR, waterbanking)

4.1. Models for Delfland

The schematic of the Delfland model is in Figure 23, and the hydraulic model for the baseline is in Figure 24.

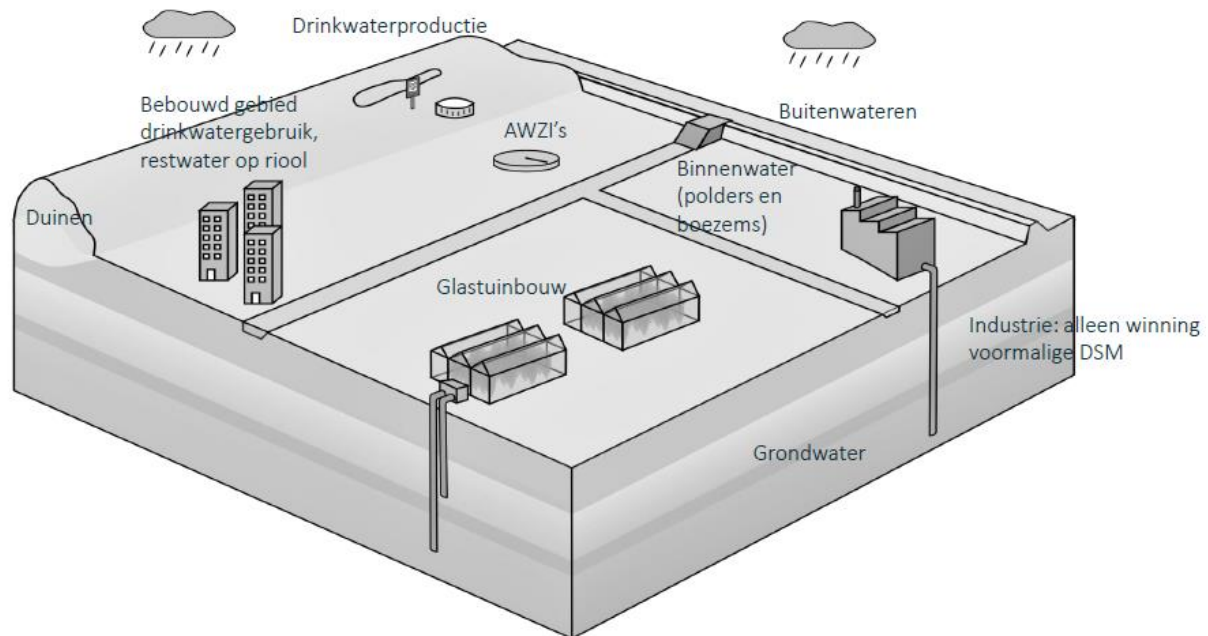

Figure 23 Model of the base-line of Delfland demo case

In the Delfland model there are 4 different blocs to be modelled:

- The urban cycle, with the drinking water treatment plant, the city, the sewer system (than mixes wastewater and rainwater), and the waste water treatment plant
- The gardens or irrigation system, with different sources of water
- The industrial park, with a unique input and output
- The regulation channel, with different inputs and outputs.

When implementing the model in the Hydroptim tool (Figure 24), as the objective is to optimize cost function, based mainly in energy cost, the elements that cannot be controlled or regulated does not affect the optimization process. This is the case for the industrial park (c) and the regulation channel (d), where the management of this systems is out of our scope. Due to this situation, in the Hydroptim model the industrial park has not been implemented, and the regulation channel has been modelled as an unregulated output.

The values in parenthesis are the average Annual Values in Millions of m³.

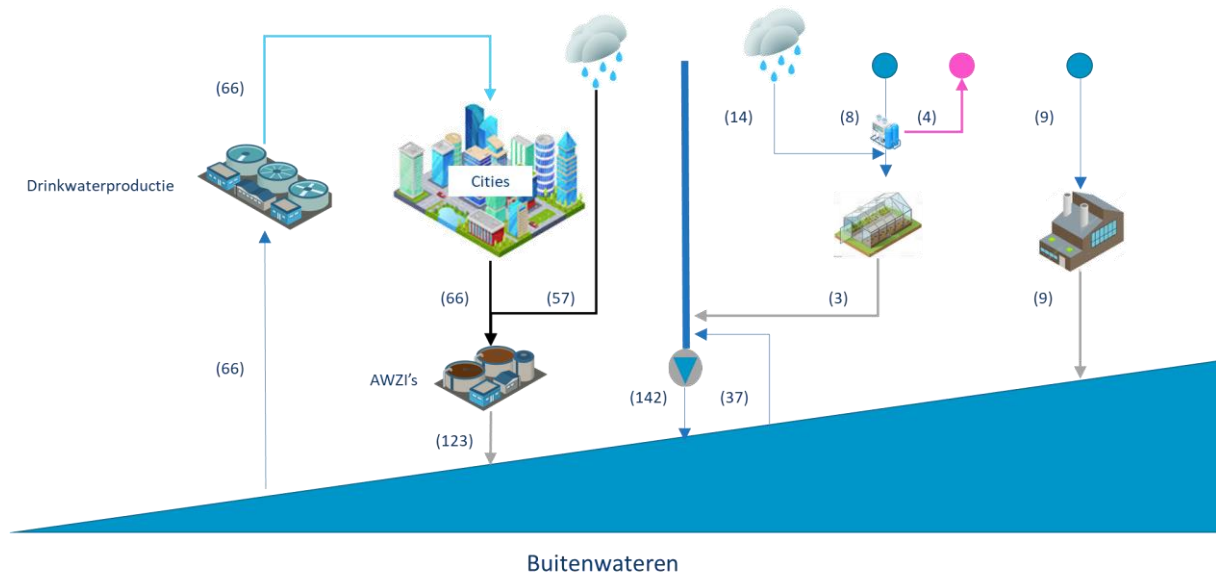

Figure 24 Hydraulic model of the base-line of Delfland demo case

4.1.1. Elements of the model

For the definition of the model, the parameters used have been provided by KWR in different files (Excel file FluxesDaily_Waterbank_Region_waterbank_basisscenario.xlsx, and Excel file Concentraties_en_vrachten_in_de_waterlijn_r2.1.0.xlsx). Table 14 shows the relation between values used in Hydroptim and data from the files.

Table 14 Elements of Delfland model

Element	Source	Parameters
Rain	Excel: FluxesDaily_Waterbank_Region_waterbank_basisscenario.xlsx Sheets: Reference Scenario Fields: Prec in basin from roofs, Prec in basin directly, Evaporation	Hourly flow = Prec in basin from roofs + Prec in basin directly – Evaporation
WTP	Excel: FluxesDaily_Waterbank_Region_waterbank_basisscenario.xlsx Sheet: Reference Scenario Field: demand greenhouse	Leak = 0,5 Max flow = max (demand greenhouse) Min flow = 0 Environmental Cost = 0 Energy Cost = 1 Weight = 1
Greenhouse demand	Excel: FluxesDaily_Waterbank_Region_waterbank_basisscenario.xlsx Sheet: Reference Scenario Field: demand greenhouse	Efficiency = 0,16 (From Figure 24: 18 (input) - 15 (output) = 3 -> efficiency 16%) Demand periodicity Daily Periodicity = demand greenhouse Daily minimum = 0
Cities Demand	Excel: Concentraties_en_vrachten_in_de_waterlijn_r2.1.0.xlsx Sheets: Conc org.stoffen incl dagdebiet Fields: De Groote Lucht, Harnaspolder, Houtrust, Nieuwe Waterweg	Weight = 1 Efficiency = 0 Demand periodicity Daily Periodicity = De Groote Lucht + Harnaspolder + Houtrust + Nieuwe Waterweg Daily minimum = 0
WWTP		Leak = 1 Max flow = max (Cities Demand) Min flow = 0 Environmental Cost = 0 Energy Cost = 1
WTP – DrinkWaterProductie		Leak = 1 Max flow = max (Cities Demand) Min flow = 0 Environmental Cost = 0 Energy Cost = 1



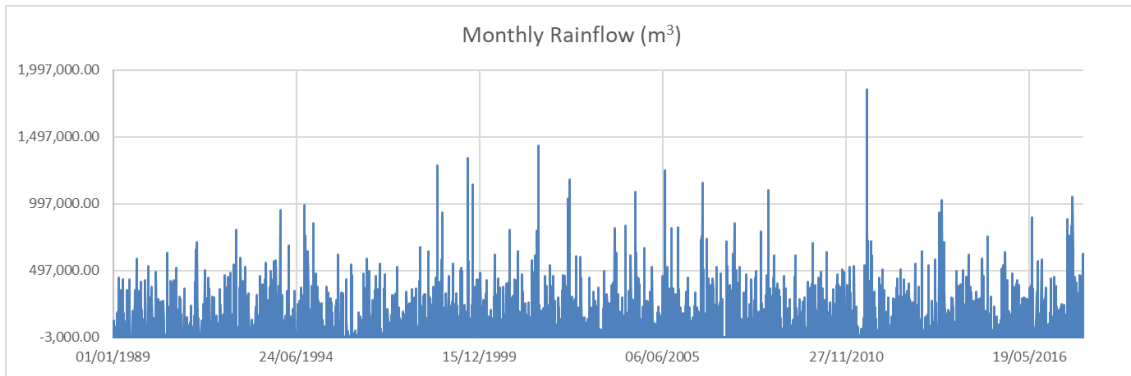

Figure 25 Rain flow used (FluxesDaily_Waterbank_Region_waterbank_basisscenario.xlsx)

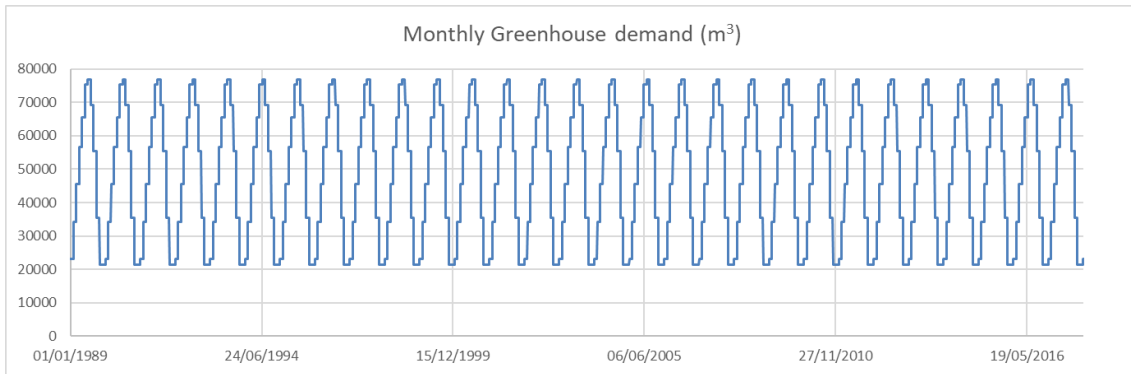

Figure 26 Greenhouse demand used (FluxesDaily_Waterbank_Region_waterbank_basisscenario.xlsx)

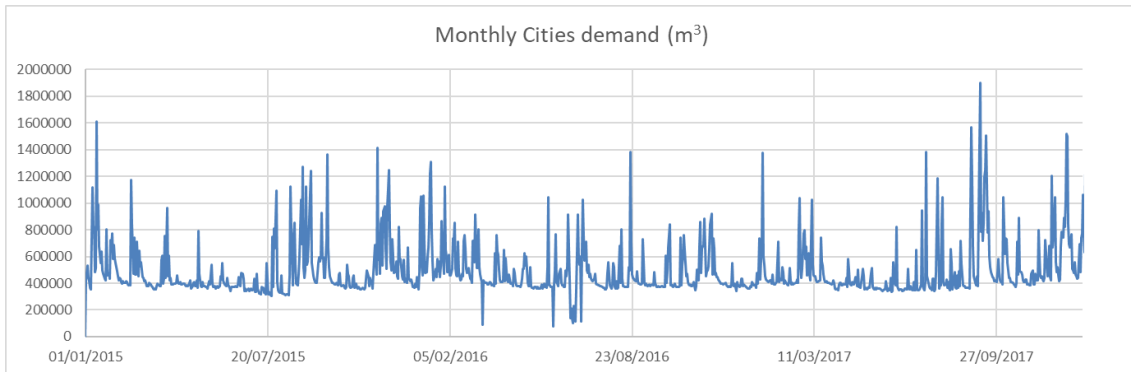

Figure 27 Cities demand used (Concentraties_en_vrachten_in_de_waterlijn_r2.1.0.xlsx)

Also, some assumptions have been made for non-available data:

- Energy Cost. A unitary cost of 1 € / kWh has been considered for all elements. Real absolute value of monetary cost calculated by Hydroptim will not be real, but comparison between scenarios is possible.
- Maximum capacity of plants. It has been considered that plants are able to provide or to treat as much water as required
- Requested volume from cities and greenhouse. It has been considered that the Hydroptim tool must ensure the monthly requested volume of water for cities and greenhouses, so once this volume has been reached in a month, the flow can be zero. This is the worst case for optimization because if monthly flows are fixed no optimization is possible.



4.1.2. Initial Scenarios

Based on model in Figure 24, three scenarios were defined for the Delfland systems, with different levels of water reuse. Based on the base-line situation, all of them uses reclaimed water from the AWZ's plat for different purposes:

- Scenario 1a and 1b. Part of the output of the wastewater treatment plant is used for irrigation instead of water from well. In scenario 1b the amount of water used for irrigation increases from 4 to 18 Mm³/year, and output from greenhouses increases from 3 to 17 Mm³/year.

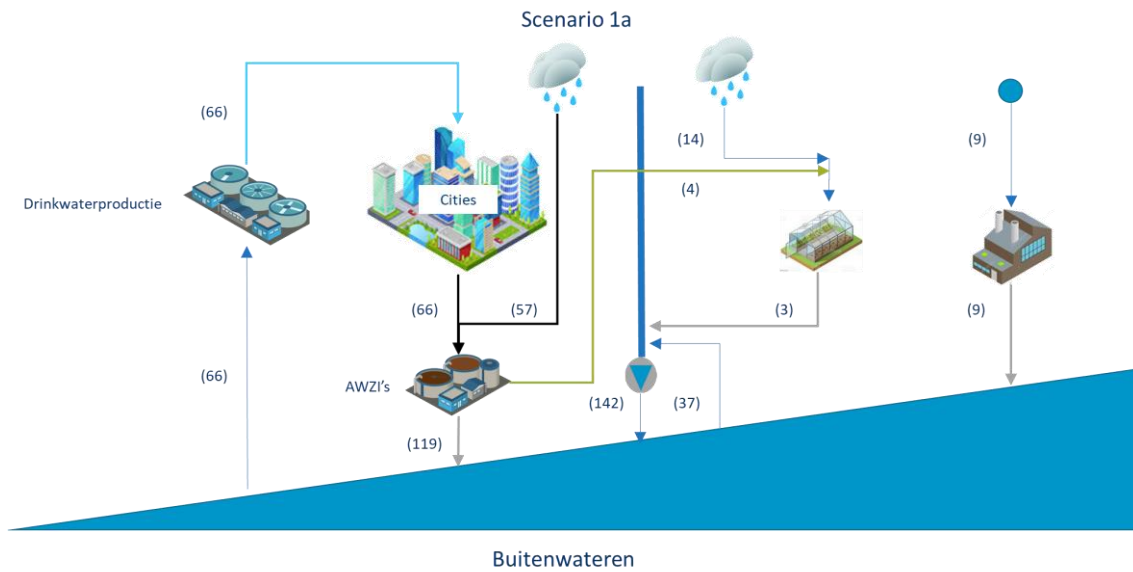

Figure 28 Model of the scenario 1a and 1b of Delfland demo case.

- Scenario 2. Part of the output of the wastewater treatment plant is used for filling the regulation channel.

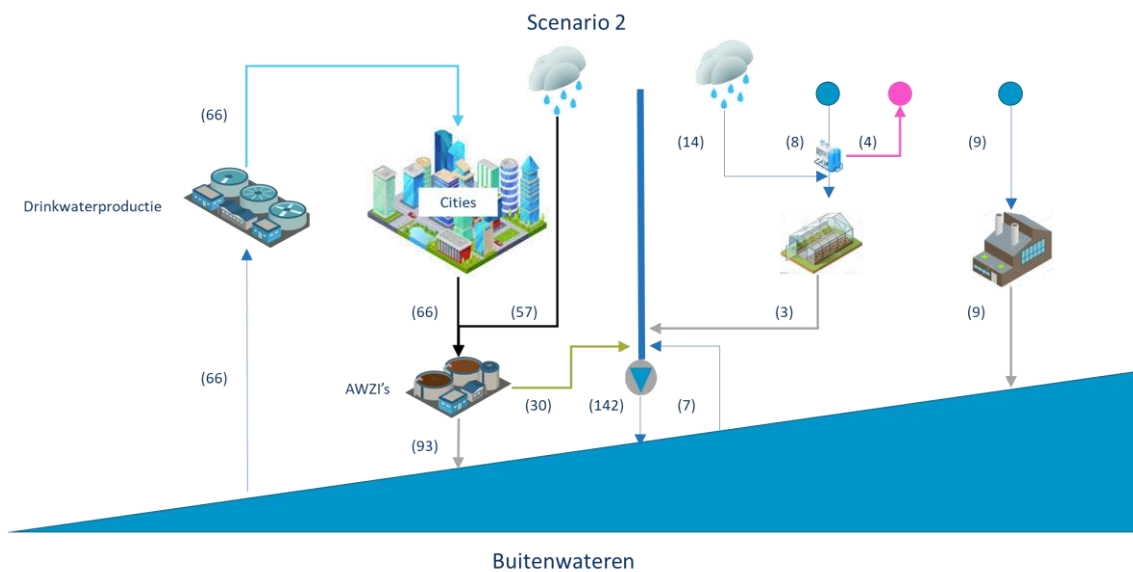

Figure 29 Model of the scenario 2 of Delfland demo case



- Scenario 3. Part of the output of the wastewater treatment plant is used as input for the Drinking Water treatment Plant.

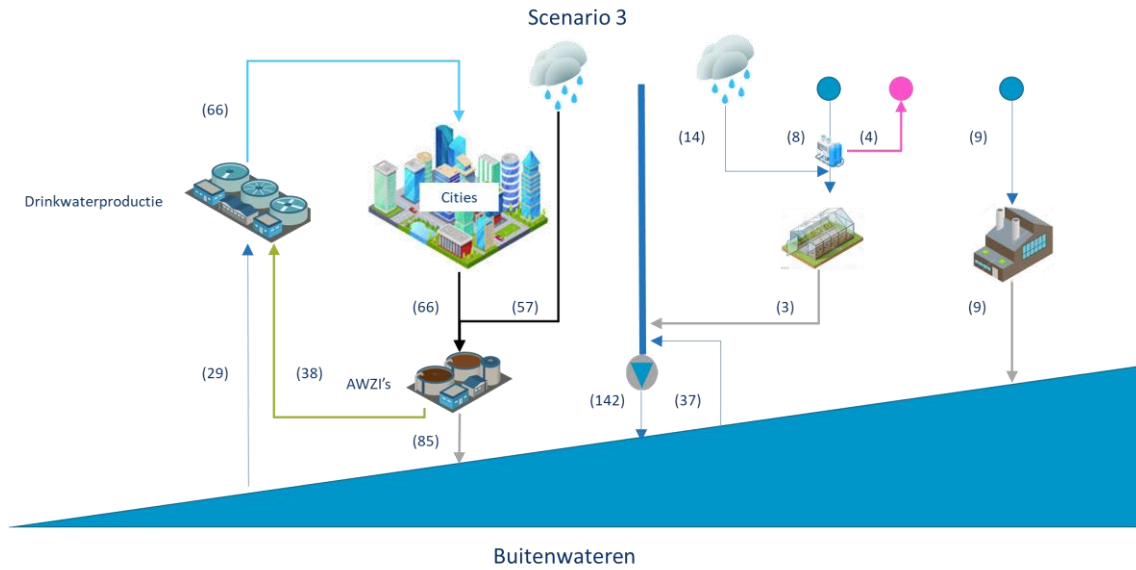

Figure 30 Model of the scenario 3 of Delfland demo case



4.2. Results of Initial Scenarios

After the first results of the "Base Line" model, the models corresponding to scenario 1 and scenario 3 have been defined and evaluated.

- The model of scenario 1 presents a recirculation of the treated water at the outlet of the AZWI plant from the branch on the left of the model towards the branch on the right of the fields and greenhouses. The water source of the well and the corresponding desalination plant that supplied the branch of the fields have been eliminated. With said recirculation, together with the rainwater collected in the branch of the fields, it is possible to supply enough water to supply the demand of the fields.
- In the case of scenario 3, the same configuration is used as in scenario 1, but instead of transporting the water to the field branch, it is recirculated to the "DrinkWaterProductie" desalination plant upstream in the same branch. In this way, it is intended to take advantage of the treated water from the AWZI instead of discharging it directly into the sea.

4.2.1. Base line

The translation of the hydraulic model of Figure 24 to Hydroptim tool is shown in Figure 31. Not all elements have been translated, as the factories on the right or the channel in the middle, because the tool cannot optimize the function of this elements: in the case of factory, there is no change in its function; and in the case of the channel, the control is done externally.

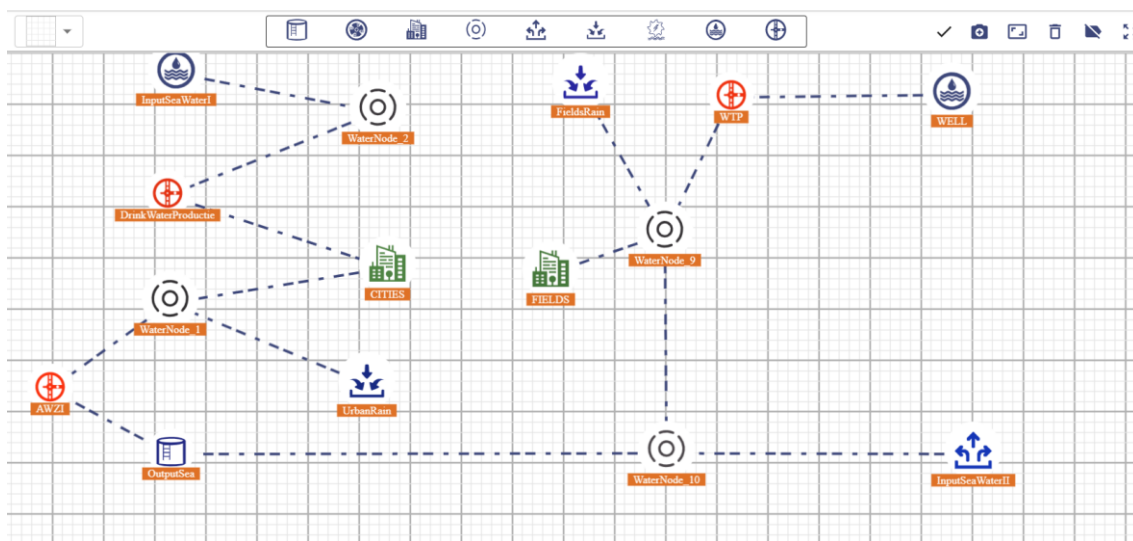

Figure 31 Hydroptim model of the baseline of Delfland demo case

Figure 32 shows the main flow of the model. With this definition, the input of the Cities is the same as the Drinking Water production.

The flow of Cities Inputs is like a digital pulse, because in the model we have indicate the maximum value supplied by the drinking water plant, and the total volume to supply monthly to the city.

The flow of the AWZi is the output of the city (equal to the input) with the rainwater.



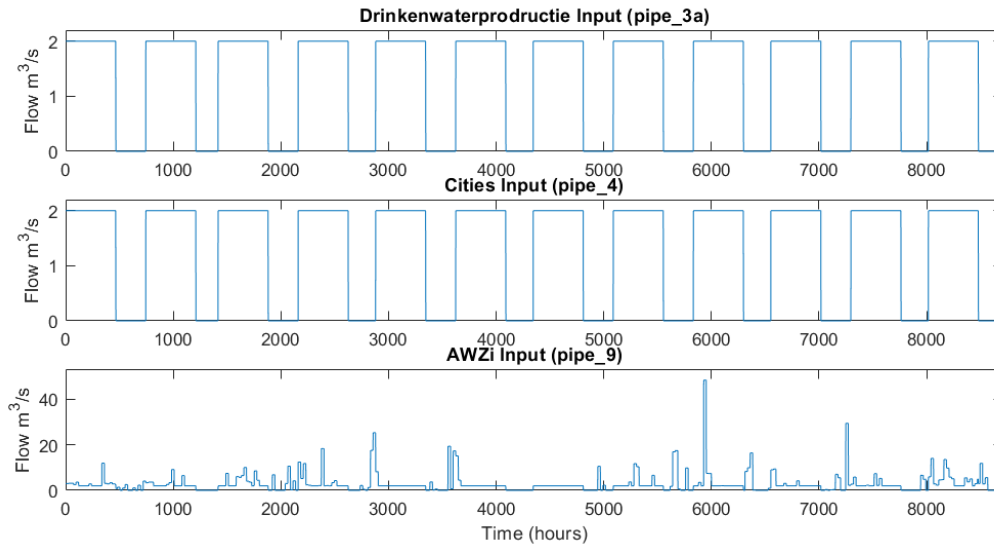

Figure 32 Main flows for base line model

4.2.2. Scenario 1

In this section, the first results obtained and some first conclusions about what was observed are presented. Figure 33 is the modified Hydroptim schematic from baseline schematic (Figure 31). Elements crossed with red lines are the elements present in baseline in Figure 31 not present in Scenario 1. Main change in pipe_3, that affects WaterNode_3 and WaterNode_9. Figure 34 shows the detail of WaterNode_3.

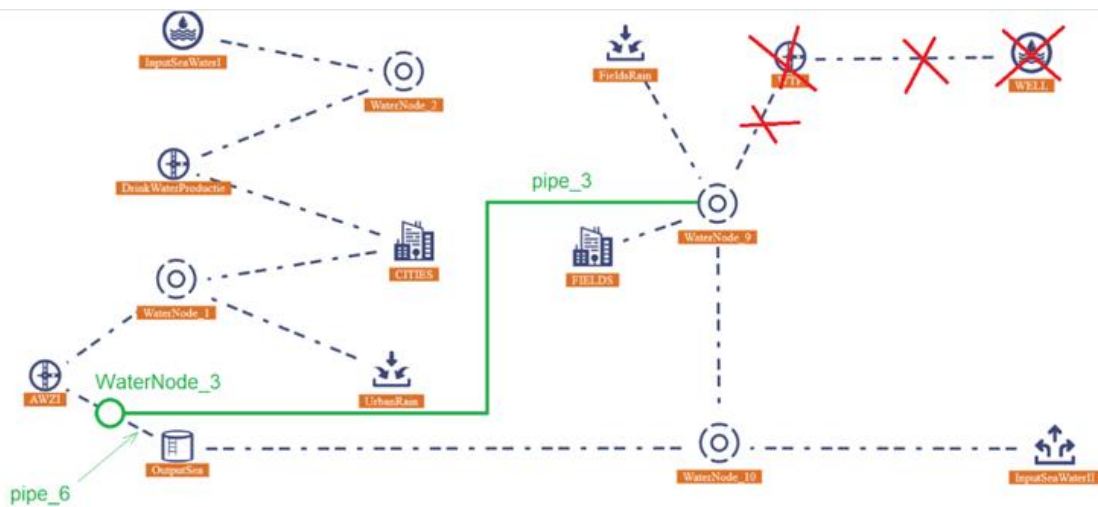

Figure 33 Changes in base line to implement Scenario 1

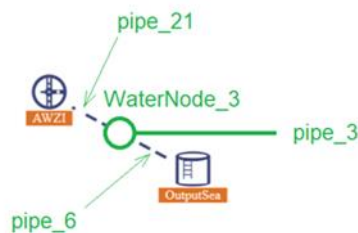

Figure 34 WaterNode_3



The flows obtained at the different elements of WaterNode_3 are shown Figure 35.

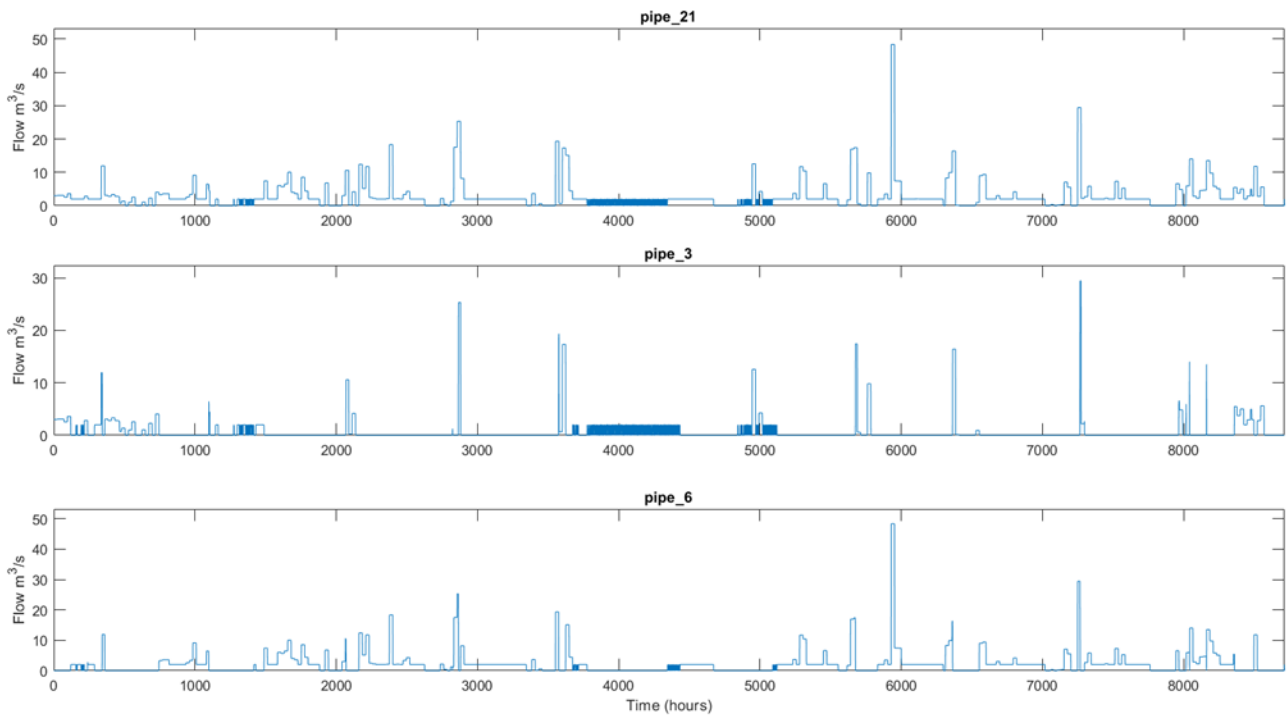

Figure 35 Flows in Pipe of WaterNode_3 for Scenario 1

Figure 36 shows the detail of WaterNode_9, affected by the addition of pipe_3.

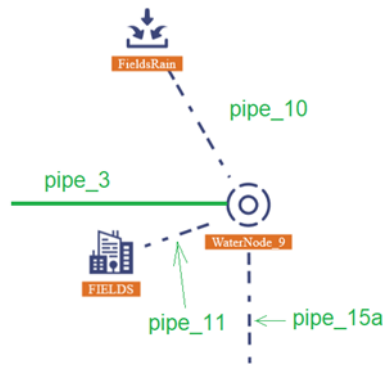

Figure 36 WaterNode_9

The flows obtained at the different elements of WaterNode_9 are shown Figure 37. It can be observed how the recirculated water (pipe_3) and rainwater (pipe_10) are able to cover the demand (pipe_11). The excess water is discharged into the sea (pipe_15a) because rain is an uncontrolled source, so the excess of water must be managed.



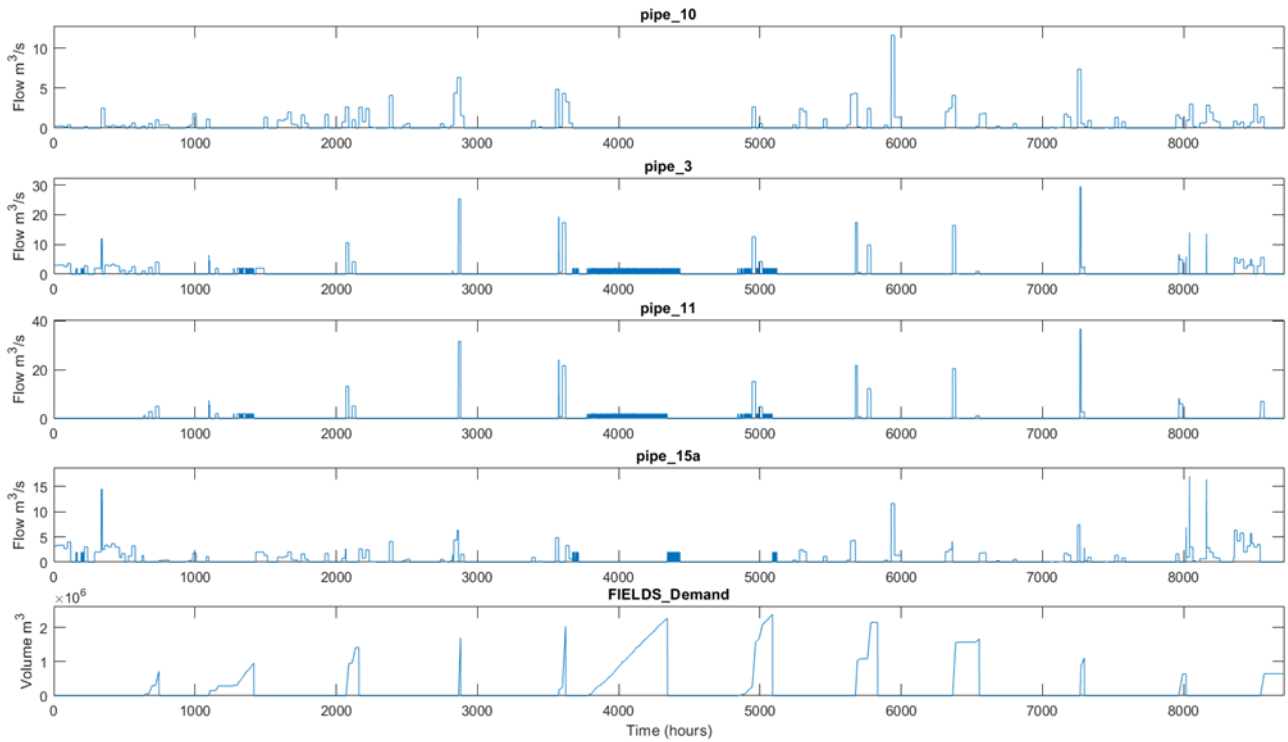

Figure 37 Flows in Pipe of WaterNode_9 for Scenario 1

4.2.3. Scenario 3

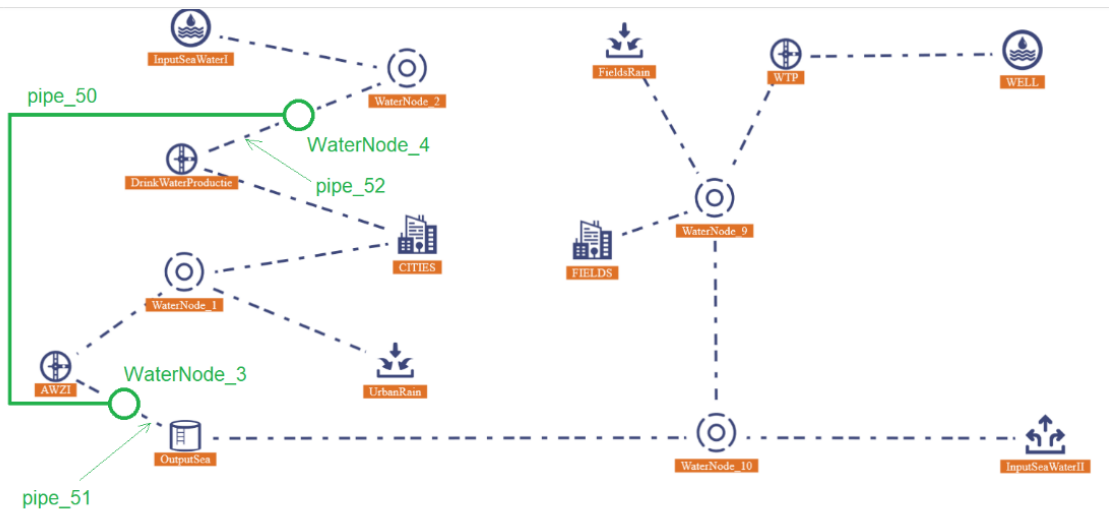

Figure 38 Changes in base line to implement Scenario 3

Figure 38 shows the changes to the Baseline Hydroptim model (Figure 31) according to Scenario 3, that is the adding of the pipe_50 and WaterNode_3 and WaterNode_4.

The details of WaterNode_3 and WaterNode_4 are shown in Figure 39, and flows of the WaterNode_4 and WaterNode_3 nodes are shown in Figure 41 and Figure 43, which are those involved in the new recirculation.



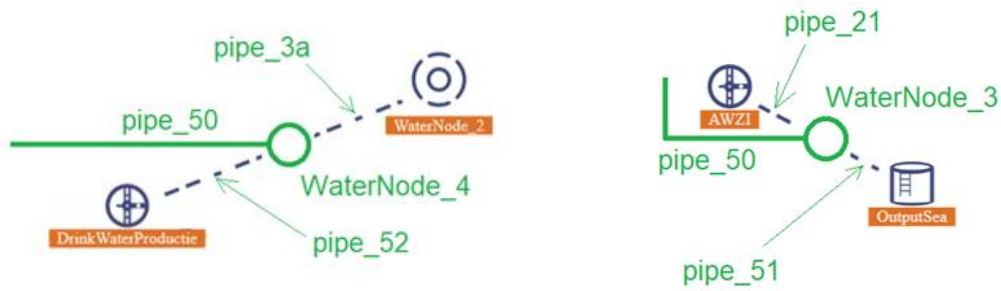

Figure 39 WaterNode_4 (left) and WaterNode_3 (right)

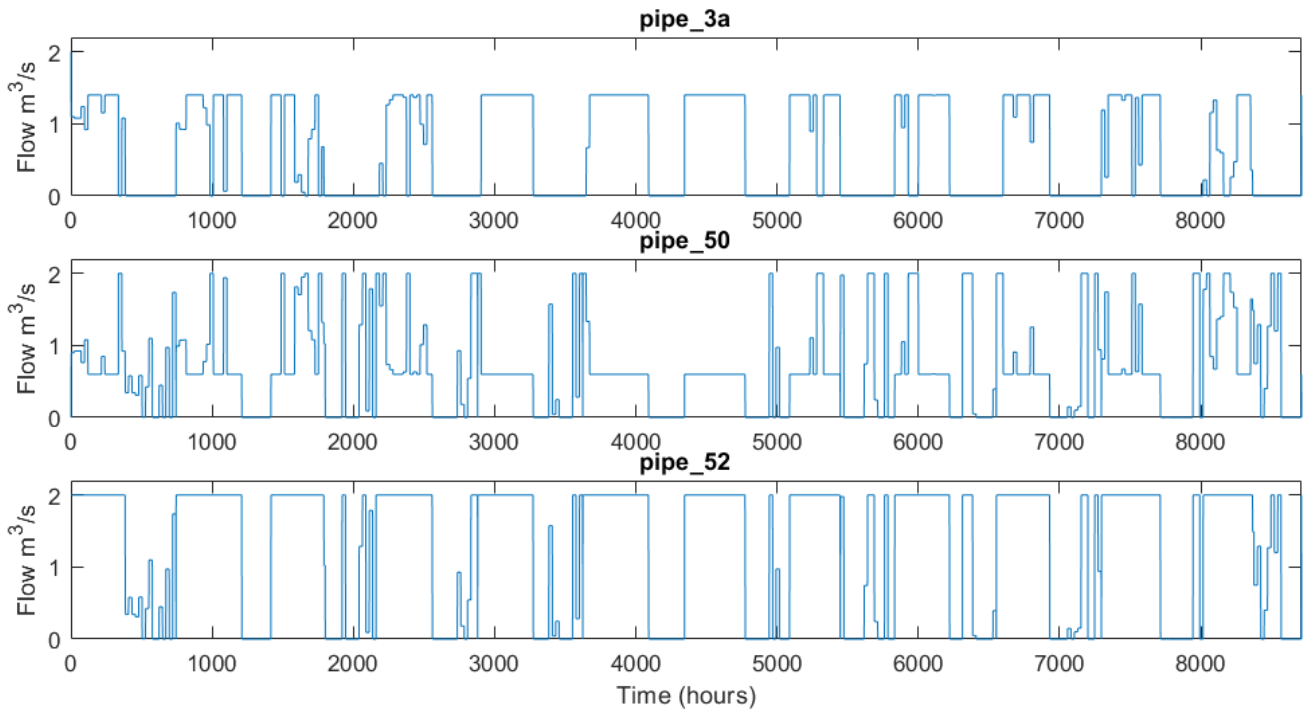

Figure 40 Flows in Pipe of WaterNode_4 for Scenario 3

Figure 40 shows the flows in WaterNode_4 (input to the Drinking Water Treatment Plant) for Scenario 3, where part of the reclaimed water from AWZI is used as input of Drinking Water Treatment Plant. In this case, the amount of water taken from the sea is lower, and – as in the base line scenario – the Hydroptim to ensure the total volume to supply monthly to the city.

Figure 41 shows the flows in WaterNode_3 (output of AWZI plant). The flow in pipe_50 is the excess water treated and not used.



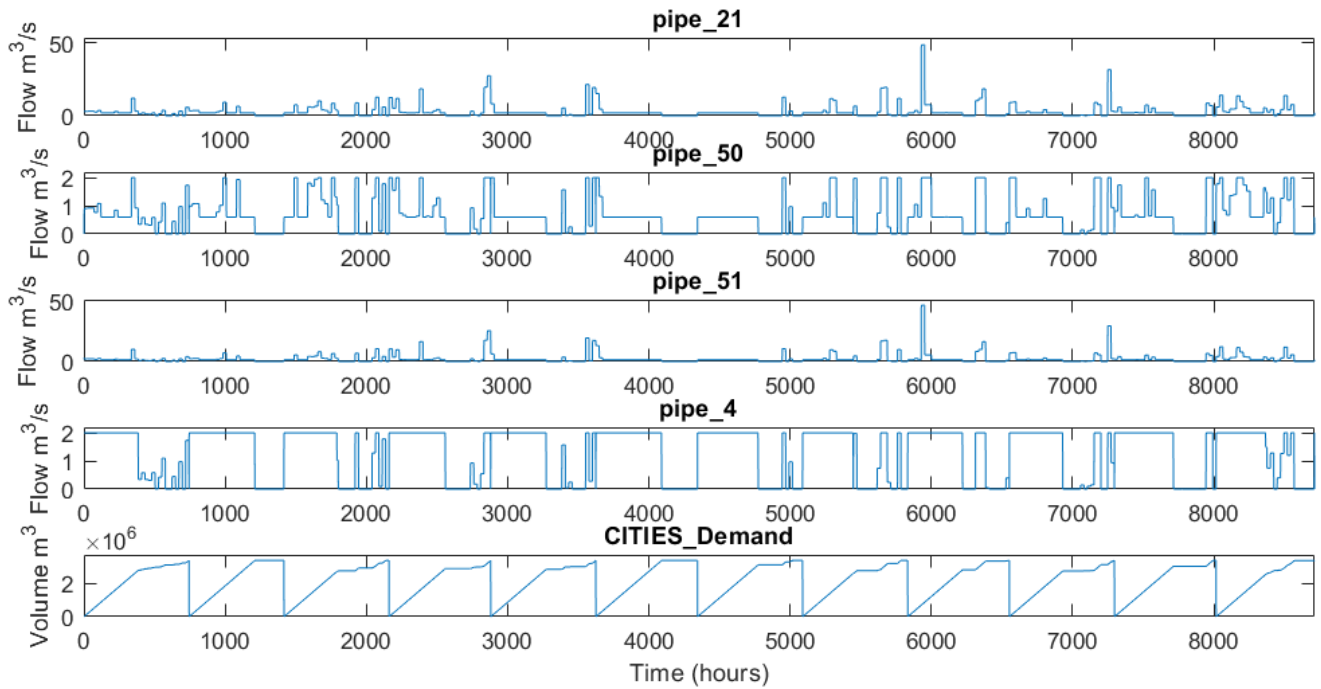

Figure 41 Flows in Pipe of WaterNode_3 for Scenario 3

For Scenario 3, also was tested the case where the 100% of wastewater treated was reclaimed and reused to the input of the drinking water treatment plant

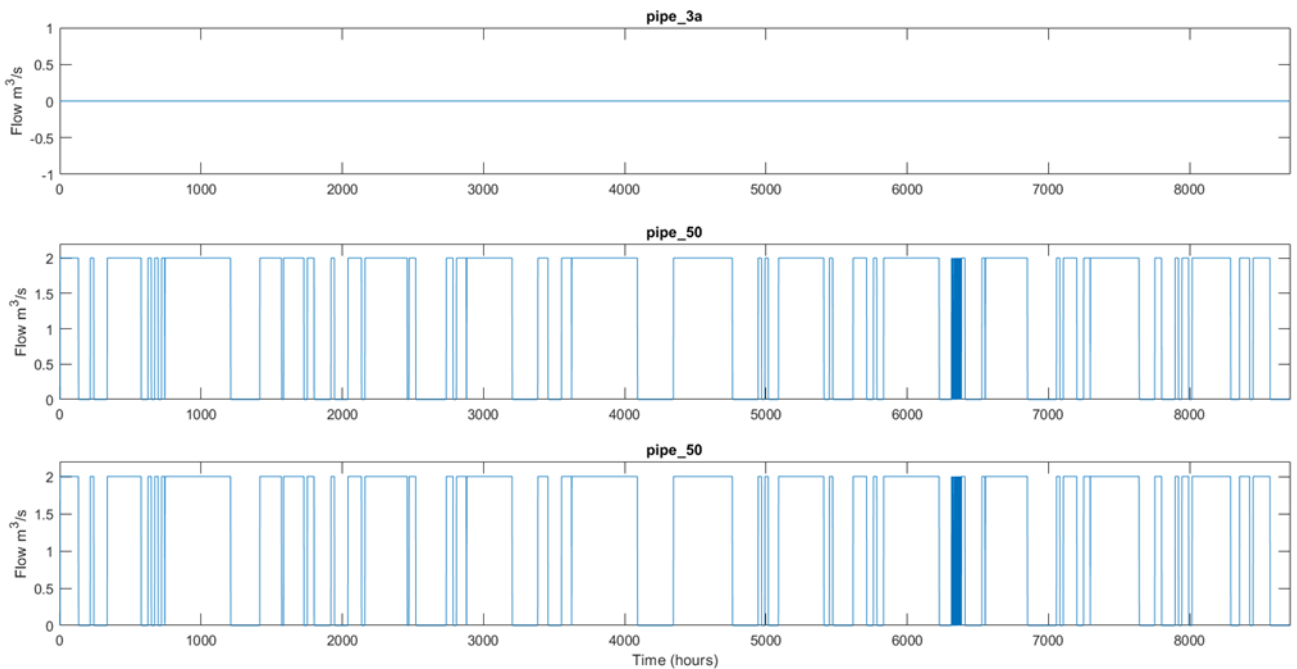

Figure 42 Flows in Pipe of WaterNode_4 for Scenario 3



It is important to notice that there is not input to the system through the pipe_3a, so no water is taken from the InputSeaWater1, and all the water used by the cities is reused after the AWZI to be directed to the Drinking Water Plant.

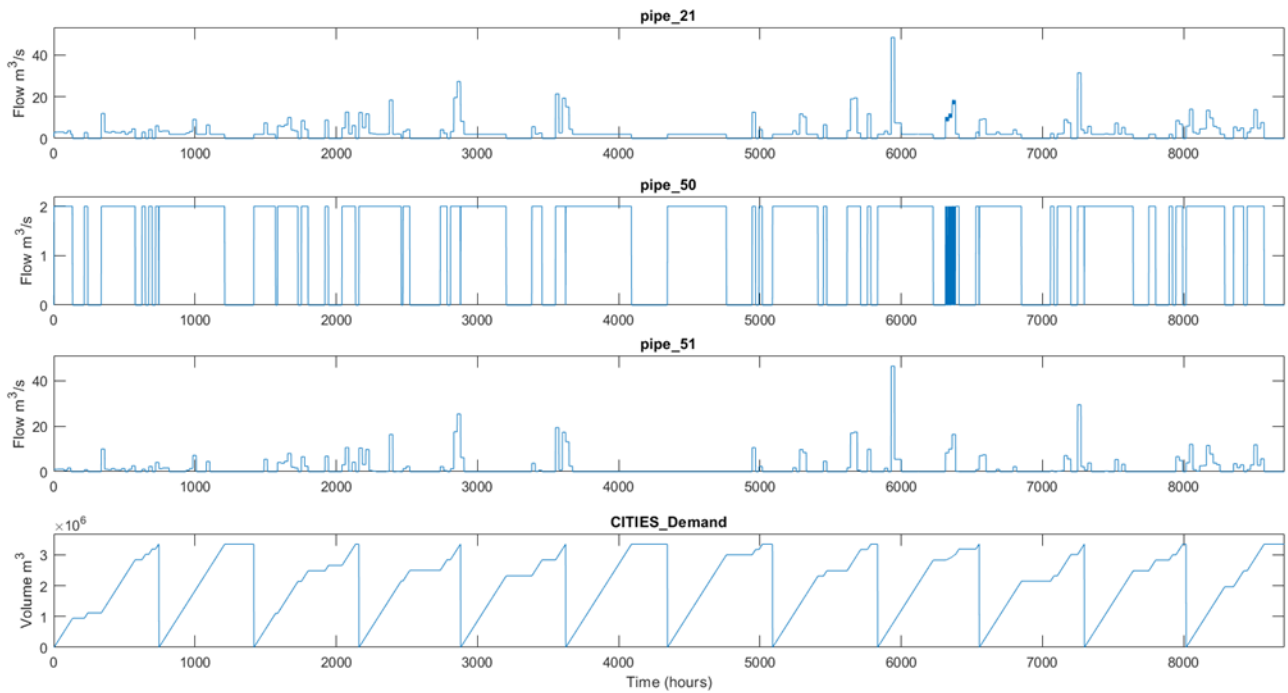

Figure 43 Flows in Pipe of WaterNode_3 for Scenario 3

It can be noticed that the output flow to the WaterNode_3 (pipe_50) is the one corresponding to the rain collected in the cities (added to the demand output): the part associated to the demand of the city is recirculated through the pipeline pipe_50, and the part of the rain is discarded into the sea (pipe_51).



The rainwater tank in Figure 44 was added because it was necessary in V3 of Scenario 1 to collect the runoff coming from the fields. It was anticipated that with this tank, it would no longer be necessary to transport water from the city's branch, but it has been observed that transport is still required. The explanation is that, even though the water is stored in the tank and used more consistently, the total amount is insufficient (even if it is used in a timely manner) to meet the demand for irrigation.

Table 16 Summary table of stress test for Scenario 1

	Rain	Deposit Rain
V0	Fields + City	No
V1	No	No
V2	City	No
V3	Fields + City	Yes

Table 17 are the results obtained in terms of the costs of each case. The total cost includes all model costs, including those of the treatment and desalination plants.

Table 17 Cost result table of stress test for Scenario 1

	Transportation Cost (€)	Rain Cost (€)	Total Cost (€)
V0	17,744	22,133	104,780,000
V1	49,035	0	67,579,000
V2	49,035	0	104,790,000
V3	6,699	22,133	104,780,000

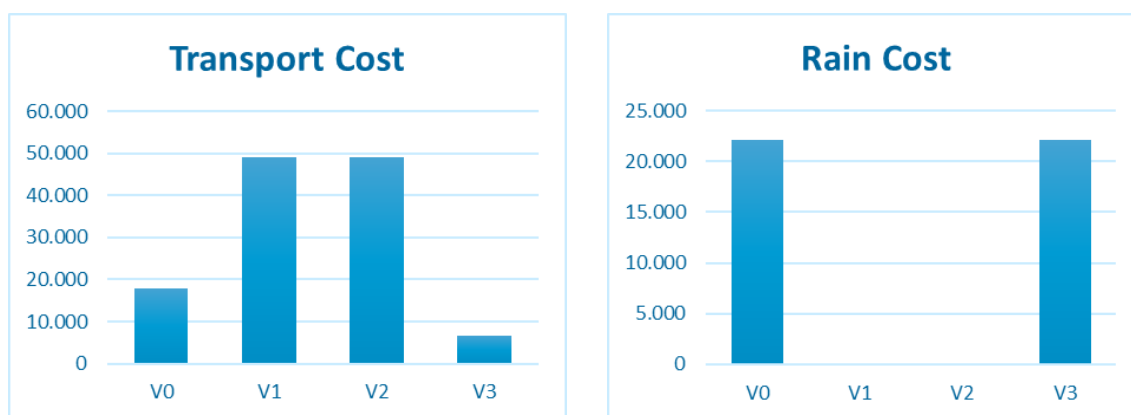

Figure 45 Cost of transport between branches (left). Cost of rain in the fields (right)



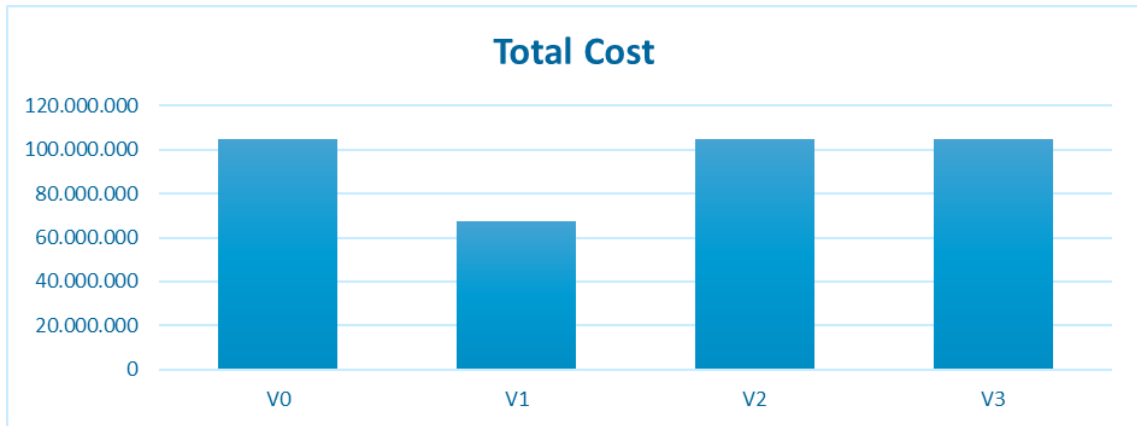

Figure 46 Total cost (€), including all network costs

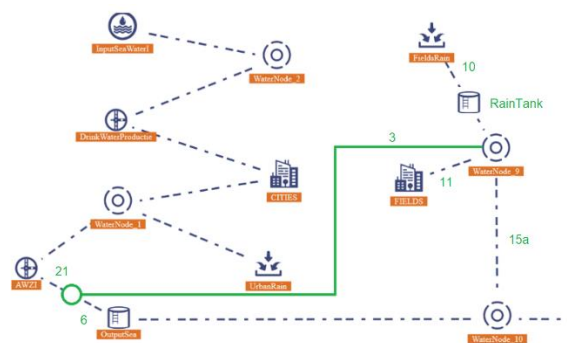

Figure 47 Identification of variables for Scenario 1

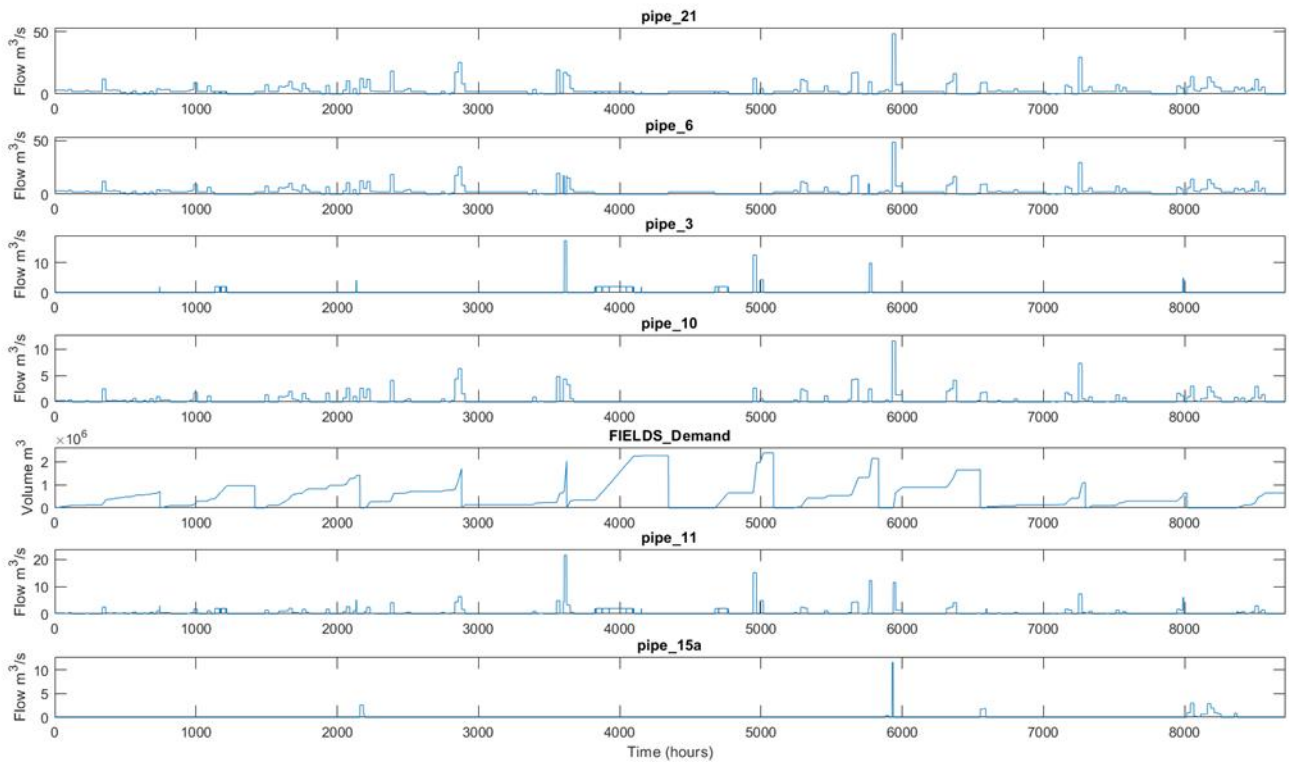

Figure 48 Different flows for Scenario 1, V0



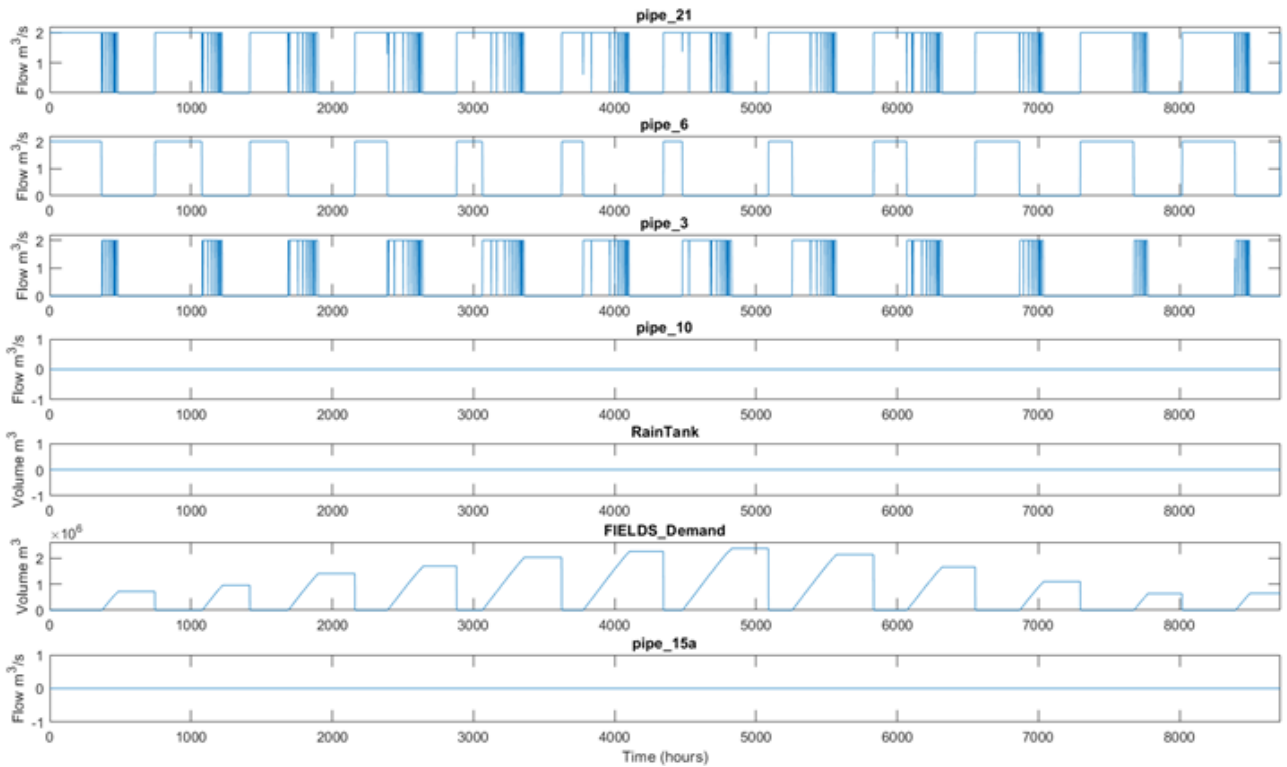

Figure 49 Different flows for Scenario 1, V1

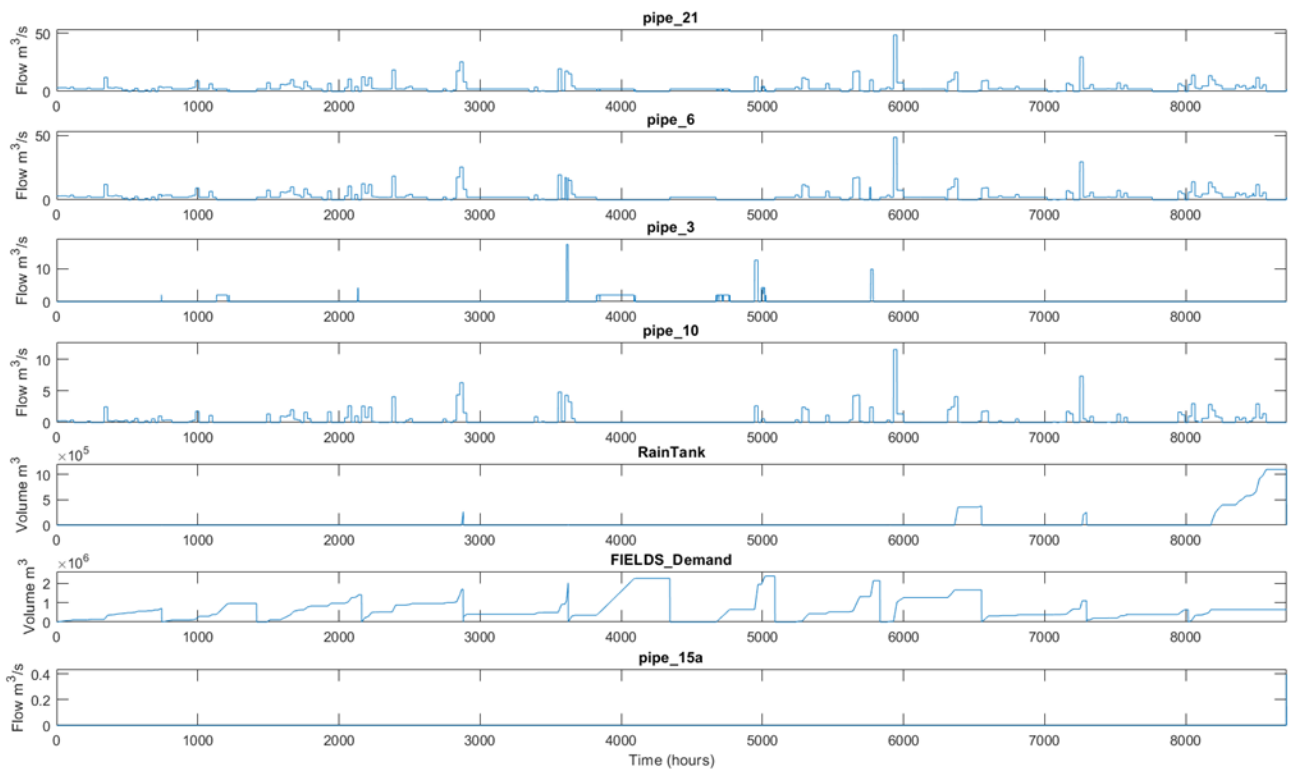

Figure 50 Different flows for Scenario 1, V2



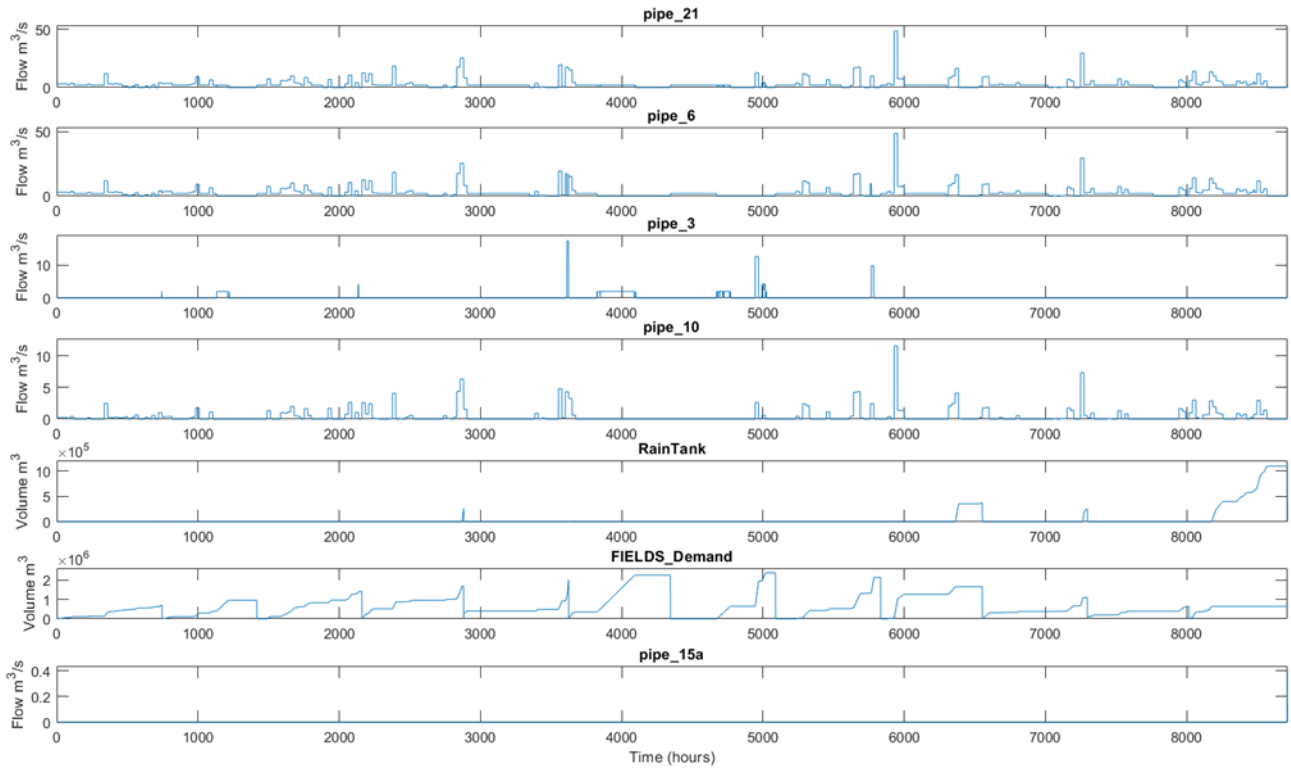

Figure 51 Different flows for Scenario 1, V3



Table 19 shows the results obtained from the costs, with the cost of seawater, the cost of rainwater and the total cost. Total cost shown here includes other costs such as those of the plants that are not shown in the table.

Table 19 Cost results table

	Sea Cost (€/m ³)	Recirculation Cost (€/m ³)	Total Cost (€)
V0	2,022	6,644	91,878,000
V1	15,310	0	91,885,000
V2	10,897	11,438	110,490,000
V3	15,635	6,699	73,292,000
V4	22,335	0	110,490,000

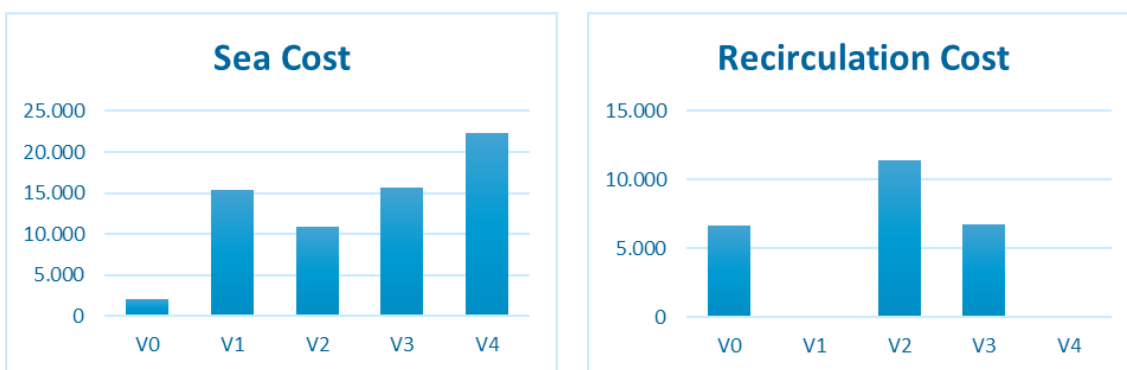

Figure 53 Cost of transport (€) between branches (left). Cost of rain in the fields (right)

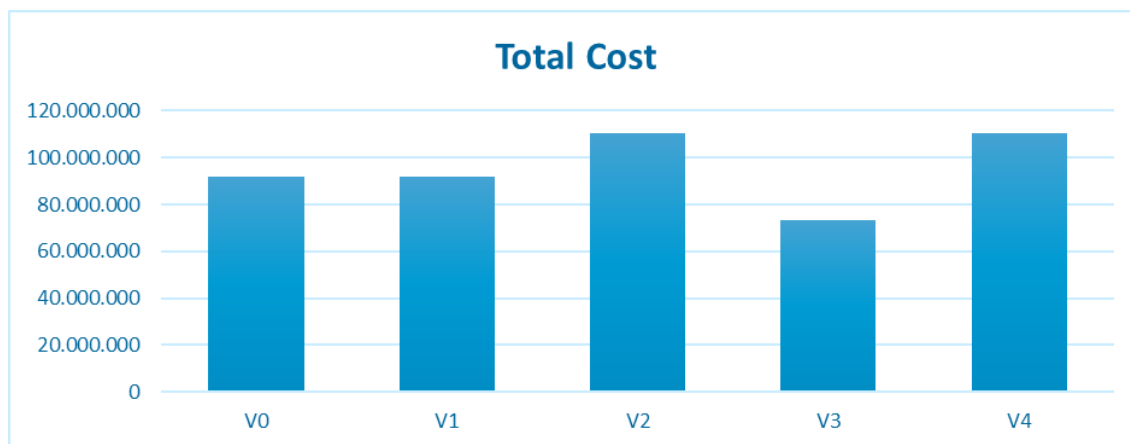

Figure 54 Total cost (€), Including all network costs



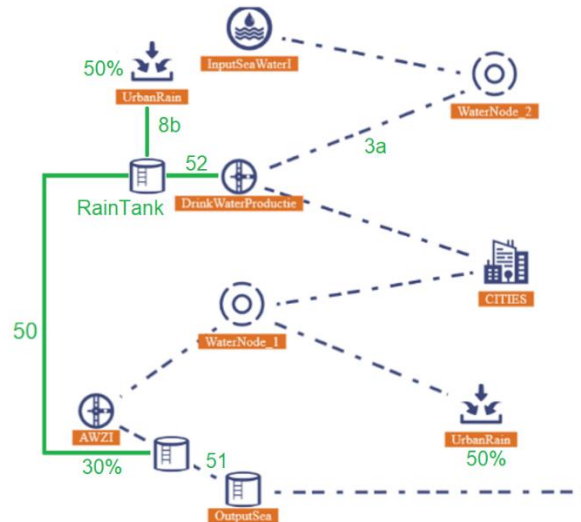

Figure 55 Identification of variables for Scenario 3

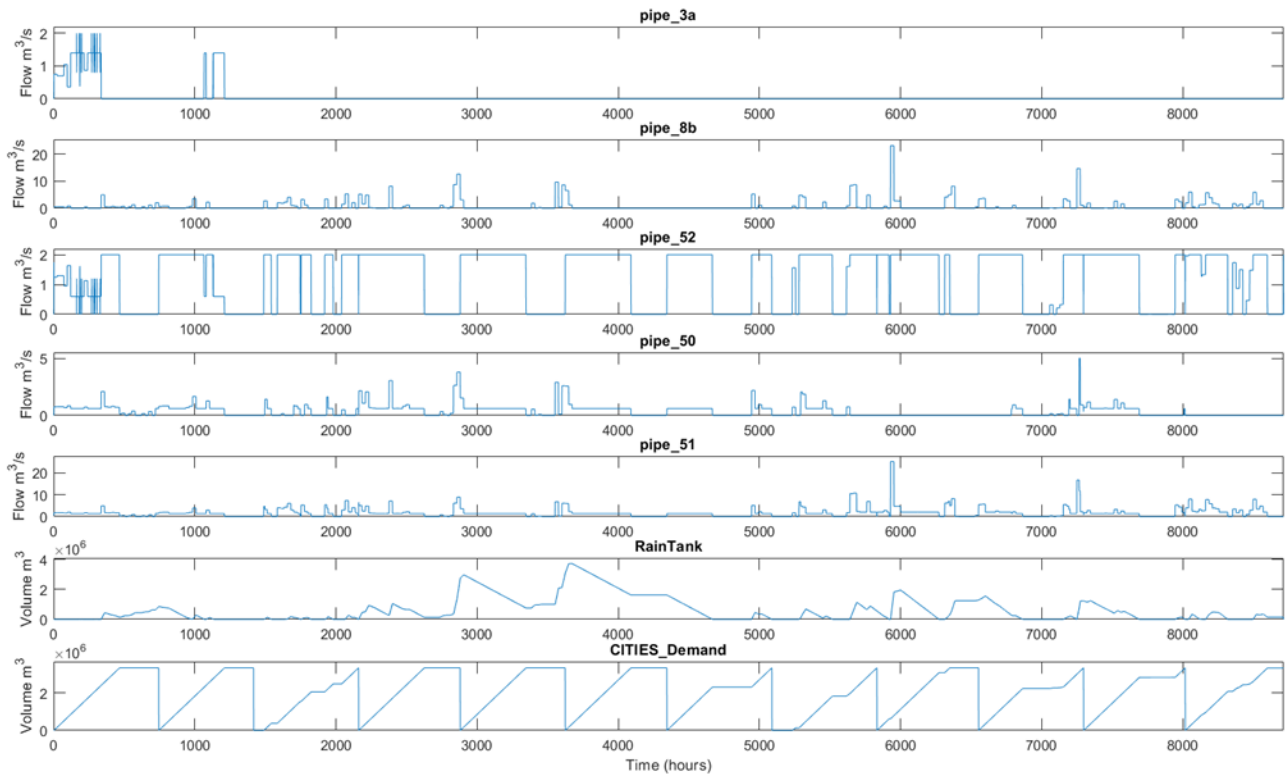

Figure 56 Different flows for Scenario 3, V0



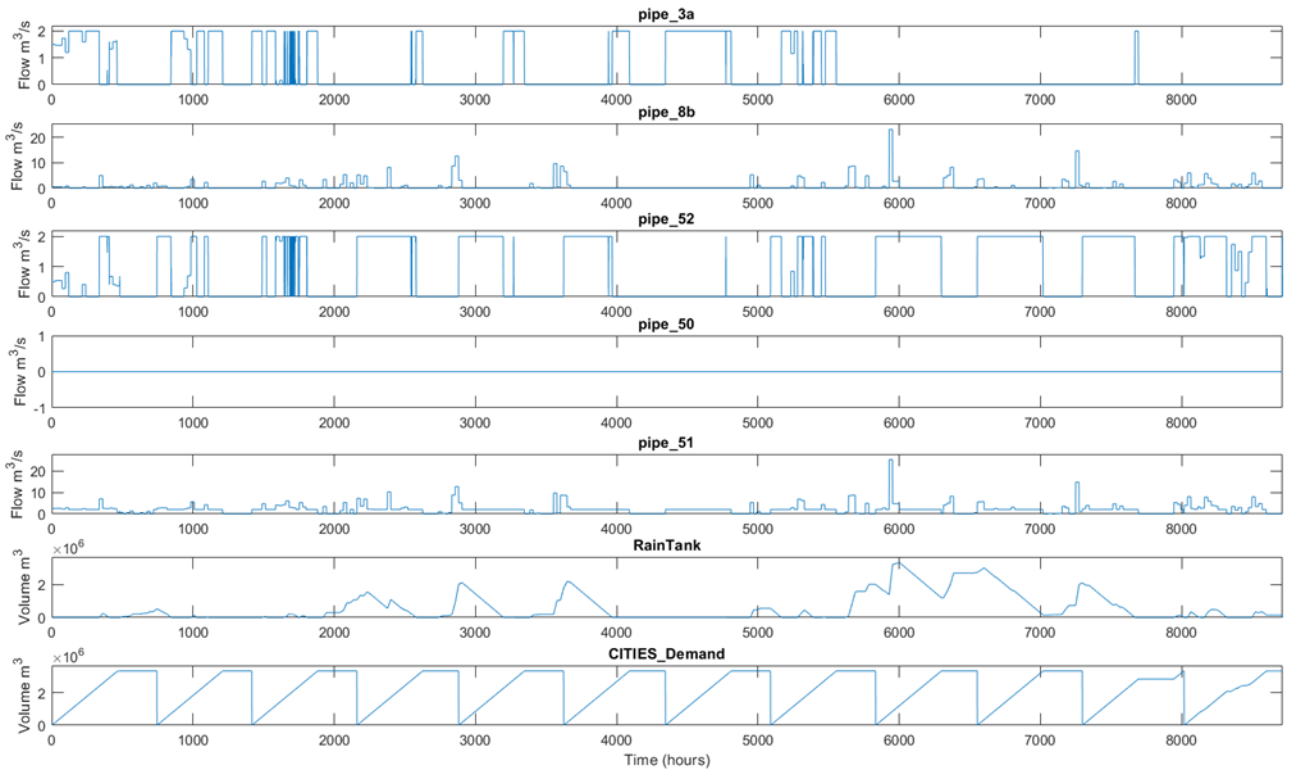

Figure 57 Different flows for Scenario 3, V1

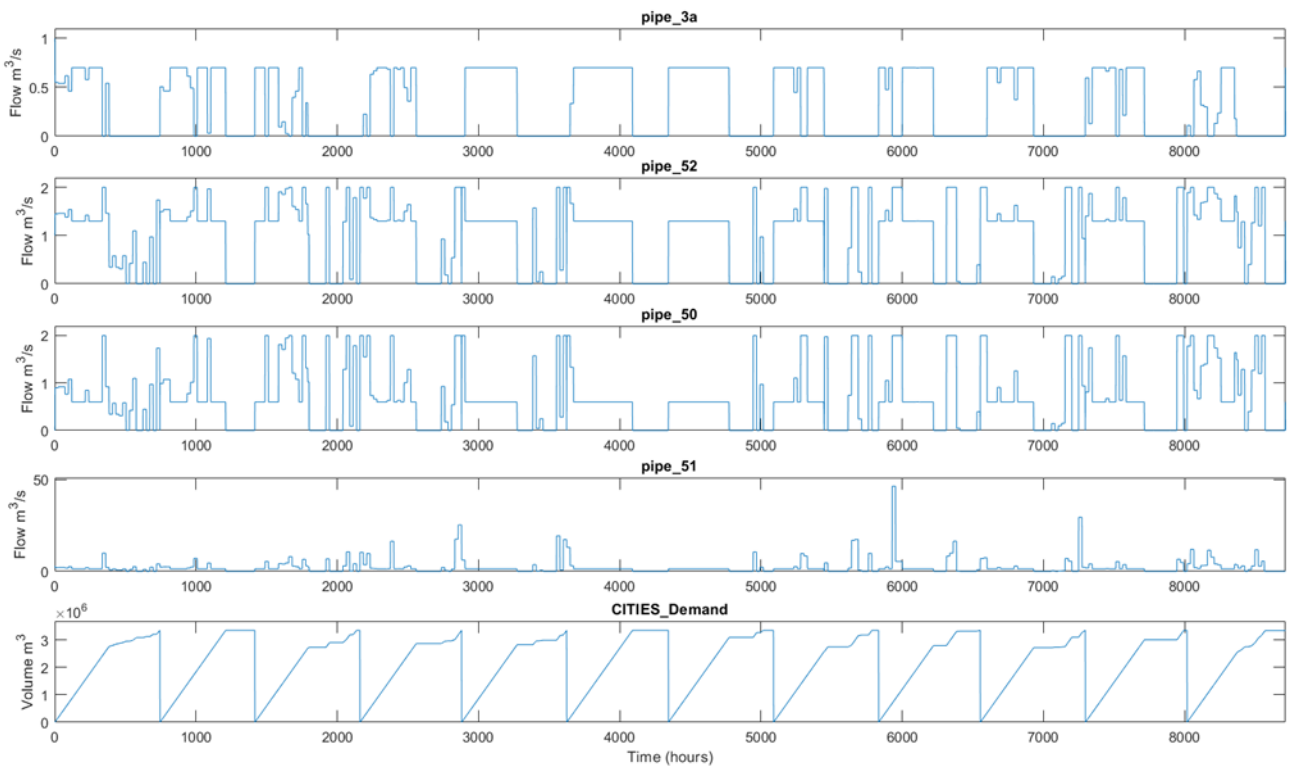

Figure 58 Different flows for Scenario 3, V2



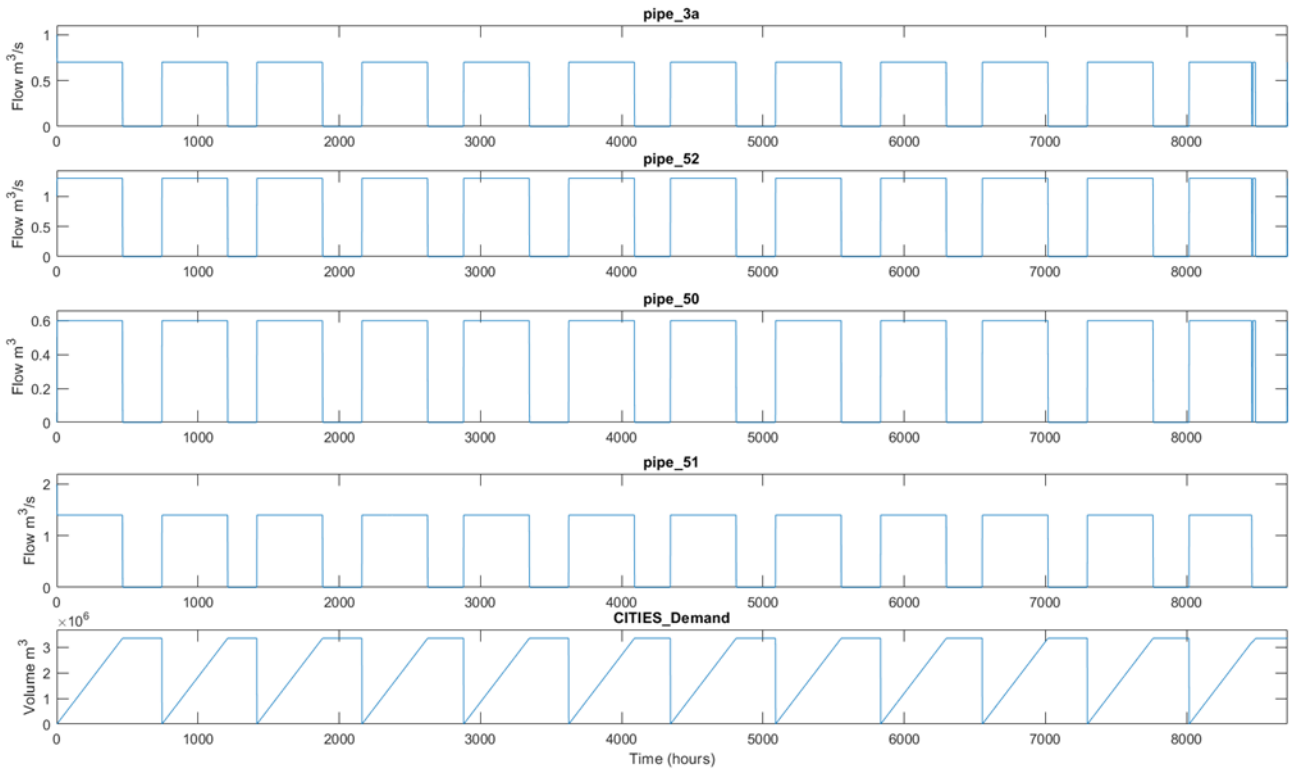

Figure 59 Different flows for Scenario 3, V3

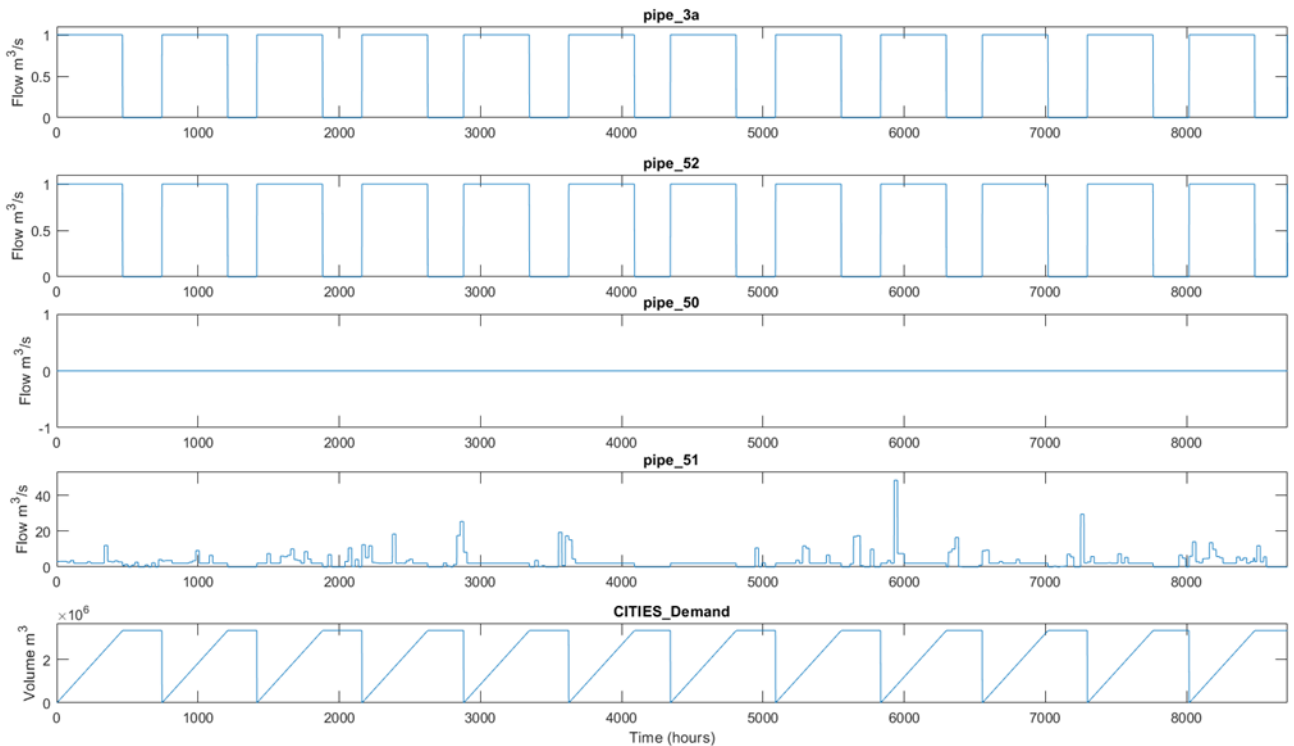

Figure 60 Different flows for Scenario 3, V4

It is observed that the recirculated water comes from the outlet of the AWZI treatment plant, that what could be treated wastewater or treated rainwater. The water is recirculated upstream of the water treatment plant. But for the rainwater, it has been treated twice, which



would not be necessary and therefore the global cost of the system is the same as in the case if the recirculation.

In the case of Scenario 3 (Figure 52), the tank added to the exit of the treatment plant eliminates the numerical problems of the loop caused by the recirculation, and perfectly solves the problem.



5. The Athens demo Case (UWOT)

5.1. Description of the set-up

Athens is the largest city in Greece in terms of population. This situation raises water scarcity issues. The Athens demo application is located in an area called Athens Plant Nursery, in the Goudi region and hosts a circular, decentralized and innovative pilot system. This mixed-use area comprises urban agricultural spaces as well as administrative uses (Plevri et al., 2019). The Athens Nursery covers an area of approximately 96 acres/0.39 km². The particular site comprises 40 acres of vegetation, supplies all urban parks and green areas of Athens with plant material and uses potable water from Athens Water Supply and Sewerage Company (EYDAP) for its irrigation (Plevri et al., 2020). According to data acquired from the Nursery and EYDAP, peak mean daily consumption (for example in summer) is estimated at 250 m³/day, while the yearly consumption is around 62,250 m³. Thus, the installation of a sewer mining (SM) unit at the point of demand would greatly support the sustainability of the area.

The sewer mining technology is an innovative way to address water scarcity issues in an urban area. Untreated wastewater is extracted from local sewers and after treatment, the produced fresh water is used directly for irrigation purposes at the point of demand. The proposed set-up consists of a sewer mining unit which produces about 25 m³/day of recycled water from wastewater to meet the demands of the Nursery.

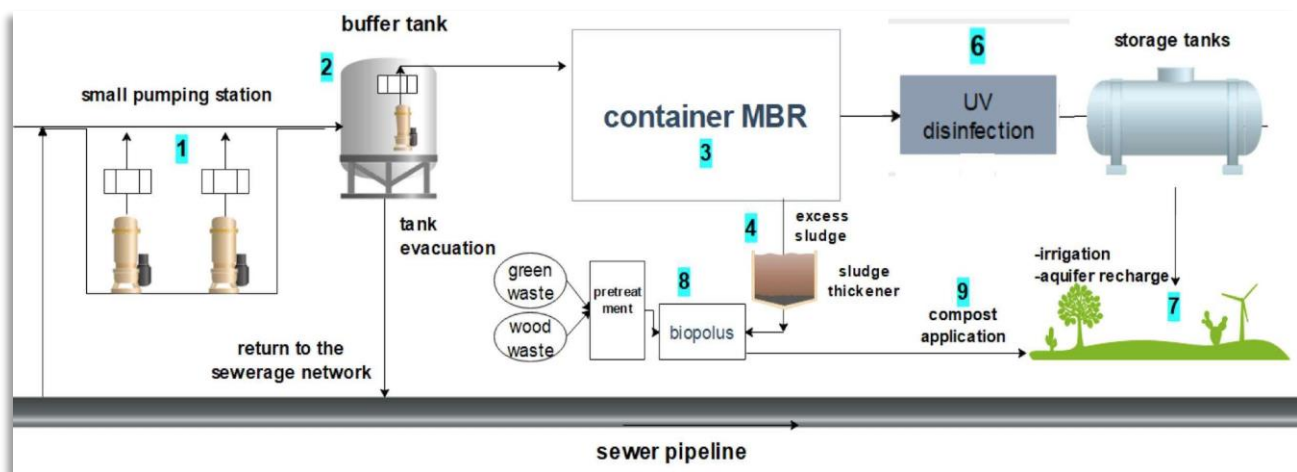

Figure 61 The Athens pilot flow diagram for water and material recovery



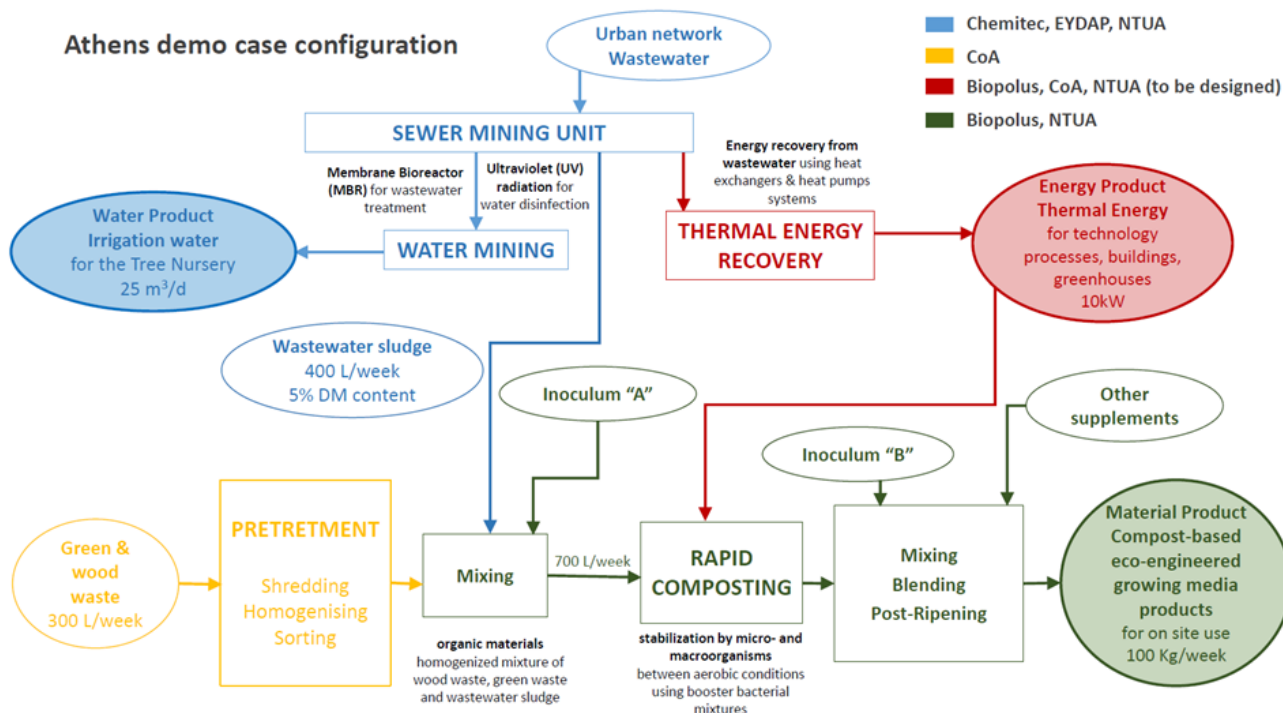

Figure 62 Diagram of the processes in the Nursery's sewer mining set-up

In Figure 61 and Figure 62, two diagrams related to the processes which take place in the Nursery's sewer mining set-up are presented. In the second figure, the blue color refers to the water cycle, the green color to the materials cycle and the red color to the energy (heat) cycle. More specifically, wastewater is extracted from a local sewer, treated at the point of demand through a sewer mining unit, which consists of a membrane bioreactor unit (MBR) along with a UV disinfection unit. After this process, the produced treated water is ready to be reused for irrigation. The produced sludge from the treatment process as well as appropriate organic waste streams from pruning are further treated via a rapid composting solution and the produced compost is used as fertiliser to cover local (on-site) needs.

5.1.1. Modelling in Urban Water Optioneering Tool (UWOT)

The Urban Water Optioneering Tool (UWOT), as referred to in Section 2.2, is a decision support tool that simulates the urban water cycle and enhances the achievement of sustainable water management. In this case study, UWOT is mainly used to assess the water flows of the sewer mining set-up in the Nursery. The collected data, which mainly concern quality characteristics of the inflow (BOD), wastewater supply provided by EYDAP, monthly timeseries for rainfall and mean temperature for a specific period of time and an estimation of water demands are used as input in the UWOT model in order to simulate the sewer mining set-up in the Nursery, as it is presented in Figure 63. The collected data along with the data sources are summarized in Table 20.



Table 20 Collected data and data sources

Data Needs	Sources
Quality characteristics of the inflow (BOD)	Athens Water Supply and Sewerage Company (EYDAP)
Wastewater supply	Athens Water Supply and Sewerage Company (EYDAP)
Monthly timeseries for rainfall and mean temperature for a specific period of time	Meteorological station in National Technical University of Athens campus in Zografou, Greece
Nursery's water needs for the irrigation of the plants	- Athens Water Supply and Sewerage Company (EYDAP) - Municipality of Athens

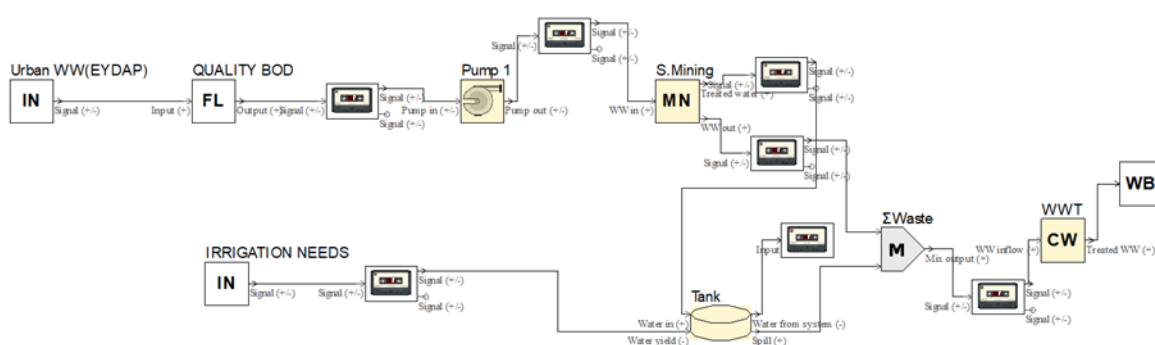

Figure 63 The set-up consisting of a sewer mining unit in UWOT

The set-up of the sewer mining unit, as it is developed in the UWOT environment, includes many different elements in order to simulate the operation of the unit for a specific period of time. The first “IN” component includes the timeseries from EYDAP, regarding the amount of wastewater. Then, a “FL” component is inserted which contains the BOD timeseries in order to control and maintain the quality at an acceptable level. After that, there is a pump that sends the water in the sewer mining unit where the treatment process takes place and, as a result, a part of the water (treated) is transferred to the tank to cover irrigation needs, whereas the rest goes to the mix “M” component. The topology includes another “IN” component with timeseries for irrigation demand, which is going to be covered by the tank. If the amount of treated water in the tank is not enough to totally cover irrigation needs, there is an extra demand from the system to cover the deficit. If the tank spills, this amount of water is mixed with wastewater from the sewer mining unit and returns to the sewerage system.

5.2. Athens

While the results of the local pilot in Athens Nursery are promising, sewer mining has the potential to be used on larger scales and for larger urban spaces. The main purpose of the upscaling analysis is to find green urban areas in Athens suitable to accommodate sewer mining units in order to cover a great part of their needs for irrigation. This analysis was carried out within a GIS software using data from the CORINE Land Cover (CLC) database. After a



classification of green urban areas based on their suitability for the implementation of sewer mining technology, in the dominant parks a simulation of sewer mining set-up took place, following the process described on previous Section.

The first step of the upscaling process was the location of green spaces in the region of Athens, using GIS software. After downloading the CORINE Land Cover (CLC) shapefile, the wider area of Athens was isolated in order to have fewer data to manage. Then the green spaces were exported by selecting only the polygons related to Corine’s class 1.4.1 Green urban areas. After having checked the results and corrected some points, the final map is shown in Figure 64.

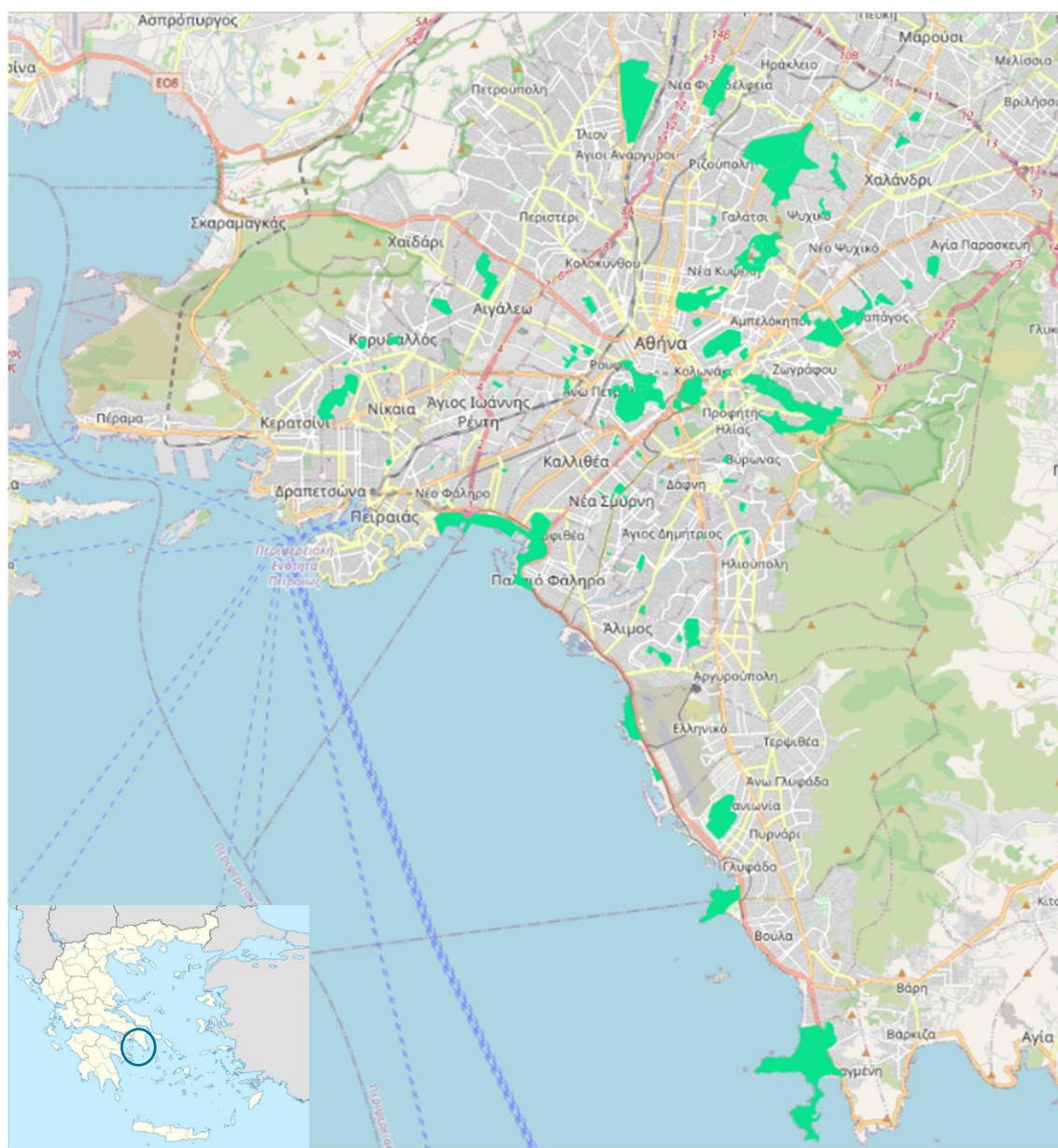

Figure 64 Green urban areas in the region of Athens



5.2.1. Multi-criteria analysis in GIS environment for the identification of potential sewer mining locations

The next step of the process was the identification of parks or green areas most suitable to establish a sewer mining set-up. The main criteria for this analysis were the area of each green space, the distance from highways or roads, the population near the parks and other relevant available data. Based on these criteria, each urban green area was categorized as shown in Figure 65. The darker the color of the polygon (green space), the more suitable the area is and the opposite.

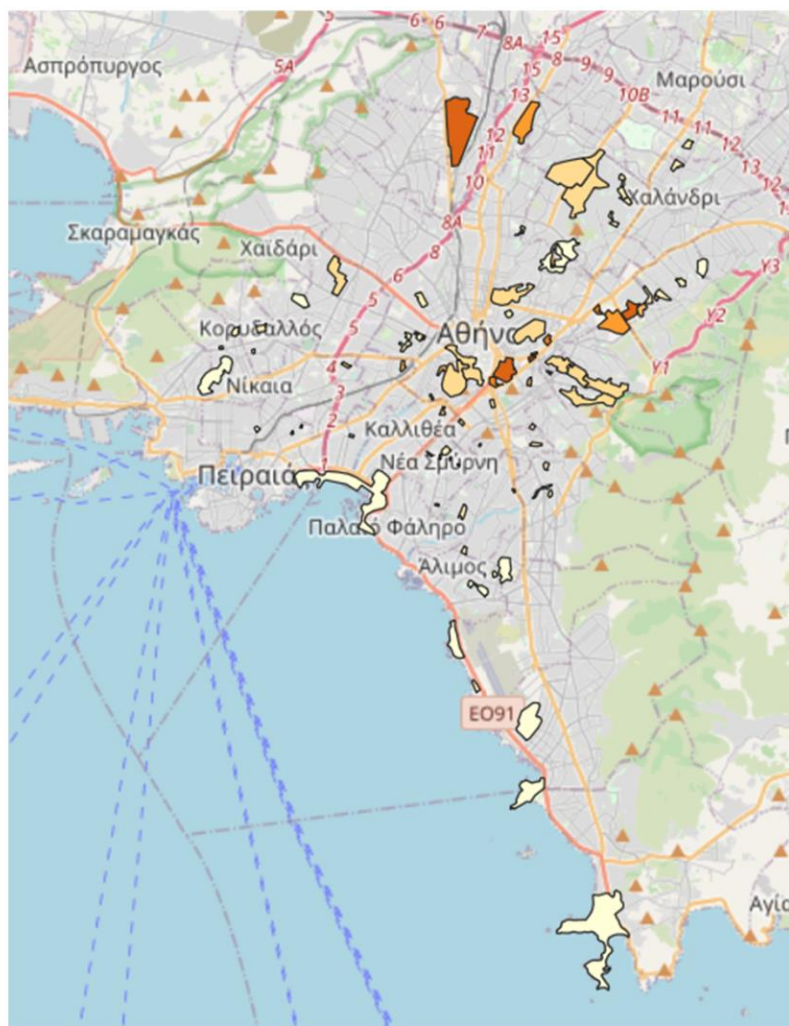

Figure 65 Results of multi-criteria analysis in GIS environment

The results of the multi-criteria analysis in GIS indicate that the most appropriate parks are: The Plant Nursery in Goudi, the Rizari Park, the “Antonis Tritsis” Metropolitan Park (A. Tritsis Management Board, 2022) and the National Garden. Taking into account that the Plant Nursery is the Athens pilot in the NextGen project and the National Garden is primarily irrigated by Peisistratian aqueduct and drillings at zero cost, Rizari Park and Antonis Tritsis were selected to be further examined regarding the implementation of a sewer mining set-up. In each park three scenarios were examined: the set-up of a sewer mining unit that produces water from treated wastewater, with a capacity of 25 m³/d, 50 m³/d and 100 m³/d.

5.2.2. Chosen parks for implementing an upscaling approach

Rizari Park, as it is illustrated in Figure 66 and Figure 67, is located in the city center and covers a green area of 12 acres, 6 acres of which are in the responsibility of the municipality of Athens to maintain. During the works for the reshaping of the park, which lasted for many years, even more “Mediterranean” trees and bushes were planted, making the vegetation denser. The annual water needs for irrigation are estimated to be approximately 8,150 m³.

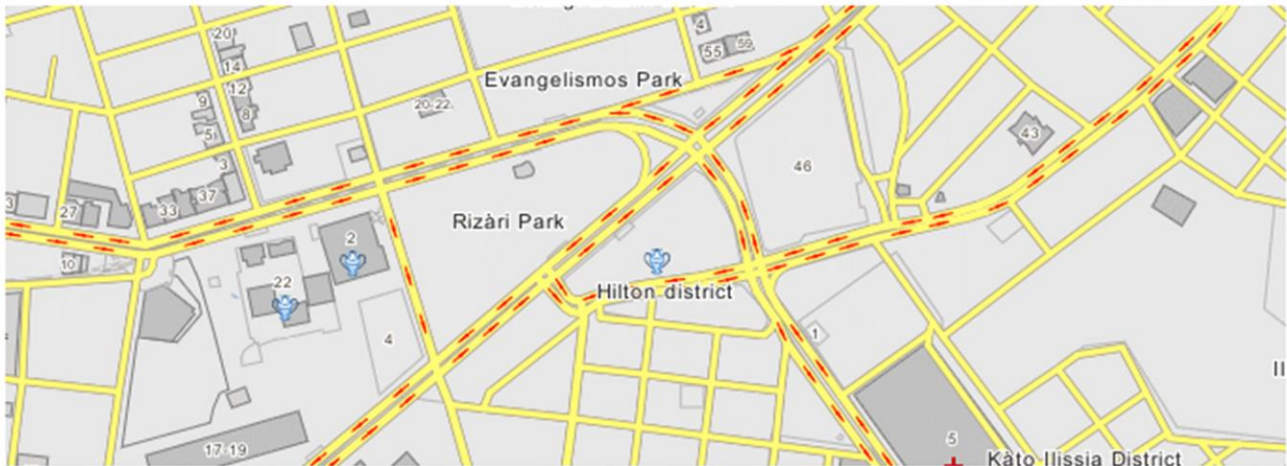

Figure 66 Rizari Park's location in Athens



Figure 67 Rizari Park

Antonis Tritsis Park, as it is shown in Figure 68 and Figure 69, is located in western Metropolitan Athens, within the administrative boundaries of the Ilion region. It is the largest Metropolitan Park of Athens and is dedicated exclusively to environmental awareness and education in Greece. It expands across 1,200 acres of land with 6 artificial lakes and connecting canals; it has 389 plant species (of which 311 are native), 110 acres of pistachio trees, 60 acres of olive trees, 182 species of birds (of the 200 that are in Attica) including predators and migratory birds; it also has freshwater fish and reptiles, thousands of bats and butterflies. In the park is located a church of architectural importance, dozens of administration buildings and numerous function halls (A. Tritsis Management Board, 2022). The green area covers approximately 918 acres and the annual water needs for irrigation of the plants is estimated to be 346,750 m³.

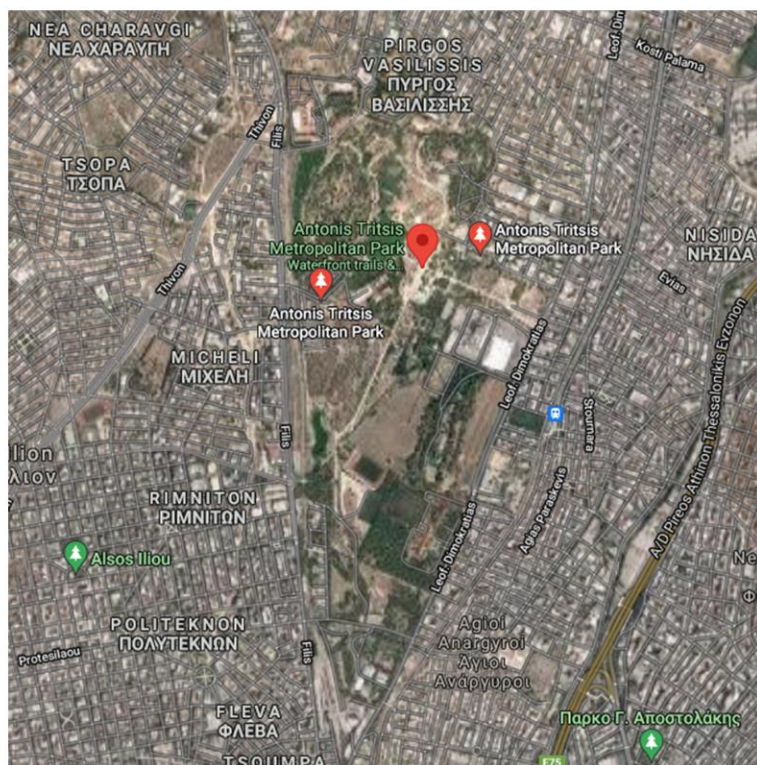

Figure 68 Antonis Tritsis Metropolitan Park's location in Athens (Source: Google Earth)



Figure 69 Antonis Tritsis Metropolitan Park



5.2.3. Modelling in UWOT and results

Following the model presented in Figure 63 and making some relevant assumptions, as it is shown in Table 21, regarding the population density around the examined parks in order to estimate the wastewater supply using the Population Equivalent PE (BOD method) and the amount of wastewater a resident in a normal house is expected to produce (170 l/d), the collected data was inserted into the UWOT tool to simulate a sewer mining set-up in both parks. The results of the analysis are described in Table 22 - Table 24.

Table 21 Assumptions related to the population and the daily wastewater supply

Parks	Inhabitants	Daily wastewater supply (m ³)
Rizari	1,000	170
Antonis Tritsis	5,000	850

The assumption regarding the population density near these two parks is shown in the second column of the Table 21. Multiplying the inhabitants with the amount of wastewater a resident in a normal house is expected to produce, that is 170 l/d, the daily wastewater supply is calculated (using BOD method) in order to be used in the analysis that follows.

Table 22 Results of simulation in UWOT tool

Capacity of SM unit: 25 m ³ /d			Capacity of SM unit: 50 m ³ /d		
Parks	Produced water (m ³ /month)	Residual wastewater (m ³ /month)	Parks	Produced water (m ³ /month)	Residual wastewater (m ³ /month)
Plant Nursery	750	3,600	Plant Nursery	1,500	2,850
Rizari		4,350	Rizari		3,600
Antonis Tritsis		24,750	Antonis Tritsis		24,000

Capacity of SM unit: 100 m ³ /d		
Parks	Produced water (m ³ /month)	Residual wastewater (m ³ /month)
Plant Nursery	3,000	1,350
Rizari		2,100
Antonis Tritsis		22,500

As it is shown in Table 22, three different capacity scenarios are examined. The first one is related to a sewer mining unit with a capacity of 25 m³/d, similar to the one established in Athens Plant Nursery. Then, this capacity was doubled and quadrupled in order to compare the results for produced water and residual wastewater. It is obvious that the selection of the capacity of a sewer mining unit is related to many elements, such as the area of the park, the water demand etc.



Table 23 Other results

Parks	Annual water demand for irrigation (m ³)	Capacity of SM unit: 25 m ³ /d	Capacity of SM unit: 50 m ³ /d	Capacity of SM unit: 100 m ³ /d
		Annual remaining demand (m ³)	Annual remaining demand (m ³)	Annual remaining demand (m ³)
Plant Nursery	62,250	53,125	44,000	25,750
Rizari	8,150	0*	0	0
Antonis Tritsis	346,750	337,625	328,500	310,250

*Rizari park's annual needs are fully covered by a SM unit with capacity of 25 m³/d.

Taking into account the annual water demand for irrigation of the three examined parks, the annual remaining demand is calculated for all capacity scenarios, and the results are shown in Table 23. It is interesting to observe that the Rizari Park, which annually demands only a small amount of water, can totally cover this need by using one sewer mining unit with a capacity of 25 m³/d. On the contrary, Antonis Tritsis Park demands a huge amount of water for irrigation and possibly needs many units of different capacities to cover a great amount of this demand.

Table 24 Cost-related results

Cost per unit for drinking water (€/m³): 1.17

Capacity of SM unit: 25 m ³ /d			Capacity of SM unit: 50 m ³ /d			Capacity of SM unit: 100 m ³ /d		
Parks	Water produced by SM unit (m ³ /year)	Total benefit (€/year)	Parks	Water produced by SM unit (m ³ /year)	Total benefit (€/year)	Parks	Water produced by SM unit (m ³ /year)	Total benefit (€/year)
Plant Nursery	9,125	10,676	Plant Nursery	18,250	21,353	Plant Nursery	36,500	42,705
Rizari								
Antonis Tritsis								
Capital Cost		120,000 €	Capital Cost		128,700 €	Capital Cost		146,100 €

The last step was the calculation of the total benefit such interventions have on the places they are established, as shown in the Table 24. The amount of water and money that is saved due to this circular decentralized technology is really significant in many cases, making such investments most preferable.

According to the results of the upscaling approach, the main conclusion is that after the detection of the most appropriate green spaces to install sewer mining units, the benefits of such set-ups can be multiple. Parks like Antonis Tritsis are highly recommended as it combines the characteristics of a large park, with plenty of vegetation which is also dedicated exclusively to environmental awareness and education. In this case, a sewer mining unit could be used for educational purposes as well.



5.3. The stress testing

Stress testing in water systems is a simulation technique used to test the resilience of water supply against possible future extreme situations. Stress tests can use historical, hypothetical or simulated scenarios. In this case the examined projections were selected from a previous project called “Simulation of water management scenarios of the Athens Water Supply System, using the Hydronomeas software” carried out by NTUA, Department of Water Resources and Environmental Engineering, on behalf of the Hellenic Ministry of Infrastructure and Transport.

In this project, different projections of demand are examined, based on the increase of the population. One projection is referred to population’s increase by 2025 and 2060, taking into account the EUROSTAT data and the other projection for the same years is related to an assumption of a realistic increase in the population of Athens. As a result, the baseline (current water demand) and four different projections are created, as follows:

- Baseline (387 hm³/year): Current water demand in Athens
- 2025 low (412 hm³/year): Water demand by 2025, taking into account the projection of EUROSTAT regarding Athens population
- 2060 low (428 hm³/year): Water demand by 2060, taking into account the projection of EUROSTAT regarding Athens population
- 2025 high (433 hm³/year): Water demand by 2025, based on the projection for realistic increase of Athens population
- 2060 high (500 hm³/year): Water demand by 2060, based on the projection for realistic increase of Athens population

5.3.1. Examination of three different scenarios of demand covered by sewer mining units

Regarding the analysis which took place in Section 5.2, the total area of urban green areas was estimated approximately 17,205 acres. It is assumed that EYDAP covers the water needs of the 60% of this area. Taking into account that the water demand for irrigation is estimated about 25 m³/month/acre, the total demand is about 3 hm³/year.

Stress testing analysis examines three different scenarios which are related to the demand covered by sewer mining units. According to this, the three examined scenarios are:

1. Scenario 0: Without sewer mining units
2. Scenario 1: Sewer mining units cover 50% of the demand for irrigation, that is 1.6 hm³/year.
3. Scenario 2: Sewer mining units cover 80% of the demand for irrigation, that is 2.5 hm³/year.

5.3.2. Results: Resilience curve and Resilience-cost diagram

Studying the Athens demand according to the baseline and the four projections mentioned above, for each demand coverage scenario, the reliability of each Athens demand projection



is examined separately, and the results are shown in Table 25 and Figure 71. As it is expected, the reliability is maximized when the water demand is low and as a result the sewer mining units can cover a significant part of this demand whereas when the demand is high, approaching about 500 hm³/year, the contribution of sewer mining units is not enough to increase the reliability of the system.

Table 25 Demand and reliability results for Athens water supply system

Scenario 0: Without sewer mining units	baseline	2025 low	2060 low	2025 high	2060 high
Athens water demand (hm ³ /year)	387	412	428	433	500
Reliability (%)	98.9	97.1	96.2	96.2	91.4

Scenario 1: Sewer mining units cover 50% of the demand for irrigation	baseline	2025 low	2060 low	2025 high	2060 high
Athens water demand (hm ³ /year)	385.4	410.4	426.4	431.4	498.4
Reliability (%)	98.9	97.2	96.3	96.3	91.6

Scenario 2: Sewer mining units cover 80% of the demand for irrigation	baseline	2025 low	2060 low	2025 high	2060 high
Athens water demand (hm ³ /year)	384.5	409.5	425.5	430.5	497.5
Reliability (%)	98.9	97.4	96.5	96.4	91.8

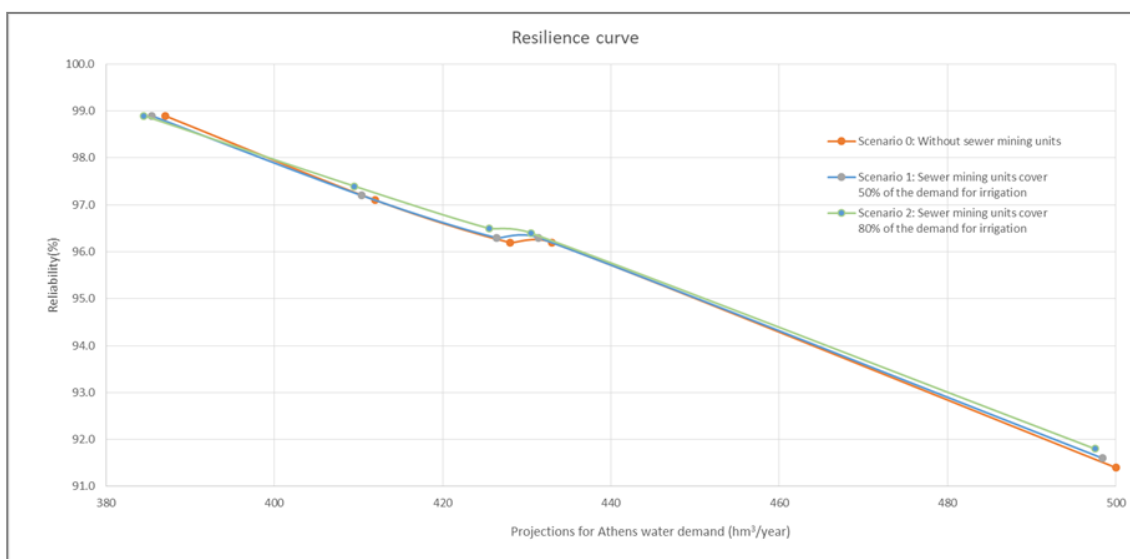

Figure 70 Resilience curve



The resilience score of each demand coverage scenario is calculated as the average reliability for all projections. These scores are shown in Table 26.

Table 26 Resilience score of three demand coverage scenarios

	Scenario 0: Without sewer mining units	Scenario 1: Sewer mining units cover 50% of the demand for irrigation	Scenario 2: Sewer mining units cover 80% of the demand for irrigation
Resilience score (%)	96.0	96.1	96.2

The establishment of sewer mining units requires a cost which includes the capital cost of the units, the operational cost and the energy cost. Next step of the procedure is the estimation of the total cost regarding Scenarios 1 and 2. According to the calculations, in Scenario 1, 42 units with capacity of 100 m³/d should be established to cover the irrigation demand whereas in Scenario 2 the number of units with the same capacity is 68. The capital cost for all units in Scenario 1 is about 6.2 mil.euros and the operational cost 0.34 mil.euros/year. As for Scenario 2, the capital cost for all units is approximately 9.9 mil.euros and the operational cost 0.54 mil.euros/year. The operational cost is estimated for 40 years (planning horizon). The energy cost and the total cost are shown in the Table 27 and Table 28 respectively.

Table 27 Energy cost for Athens' water supply system

Scenario 0: Without sewer mining units	baseline	2025 low	2060 low	2025 high	2060 high
Athens water demand (hm ³ /year)	387	412	428	433	500
Energy cost (mil.euros/year)	2.29	2.72	3.40	3.41	6.56

Scenario 1: Sewer mining units cover 50% of the demand for irrigation	baseline	2025 low	2060 low	2025 high	2060 high
Athens water demand (hm ³ /year)	385.40	410.40	426.40	431.40	498.40
Energy cost (mil.euros/year)	2.26	2.69	3.36	3.36	6.51

Scenario 2: Sewer mining units cover 80% of the demand for irrigation	baseline	2025 low	2060 low	2025 high	2060 high
Athens water demand (hm ³ /year)	384.50	409.50	425.50	430.50	497.50
Energy cost (mil.euros/year)	2.24	2.66	3.33	3.34	6.48

Table 28 Total cost of three demand coverage scenarios

	Scenario 0: Without sewer mining units	Scenario 1: Sewer mining units cover 50% of the demand for irrigation	Scenario 2: Sewer mining units cover 80% of the demand for irrigation
Cost (mil.euros)	147	165	176
Resilience score (%)	95.96	96.06	96.2



To sum up, the Figure 71 illustrates the Resilience - Cost diagram as it turns out from the stress testing analysis. The diagram shows that there is a significant increase in the cost in order to achieve a small increase in the resilience. This is logical taking into account the Athens complex water system and the more and more increasing water demand. Sewer mining units can cover a significant part of irrigation demand but not a large amount of total water demand of Athens.

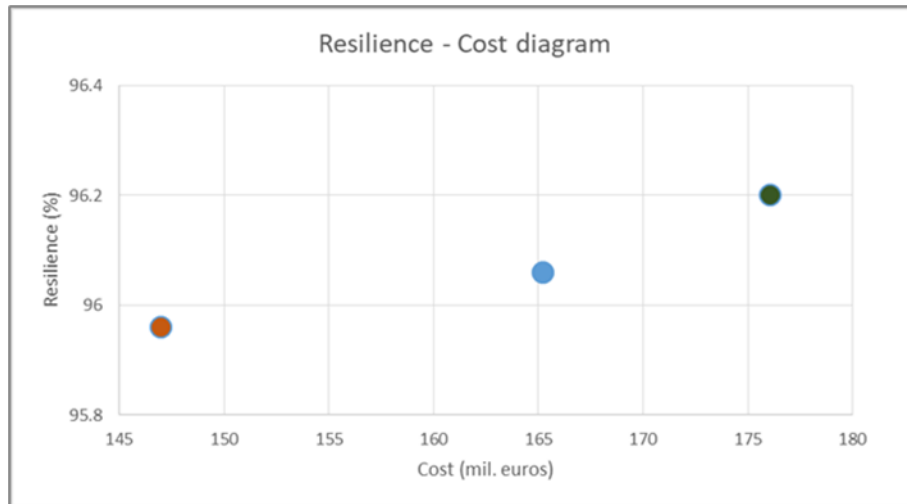

Figure 71 Resilience - Cost diagram



6. The Delfland demo case (UWOT)

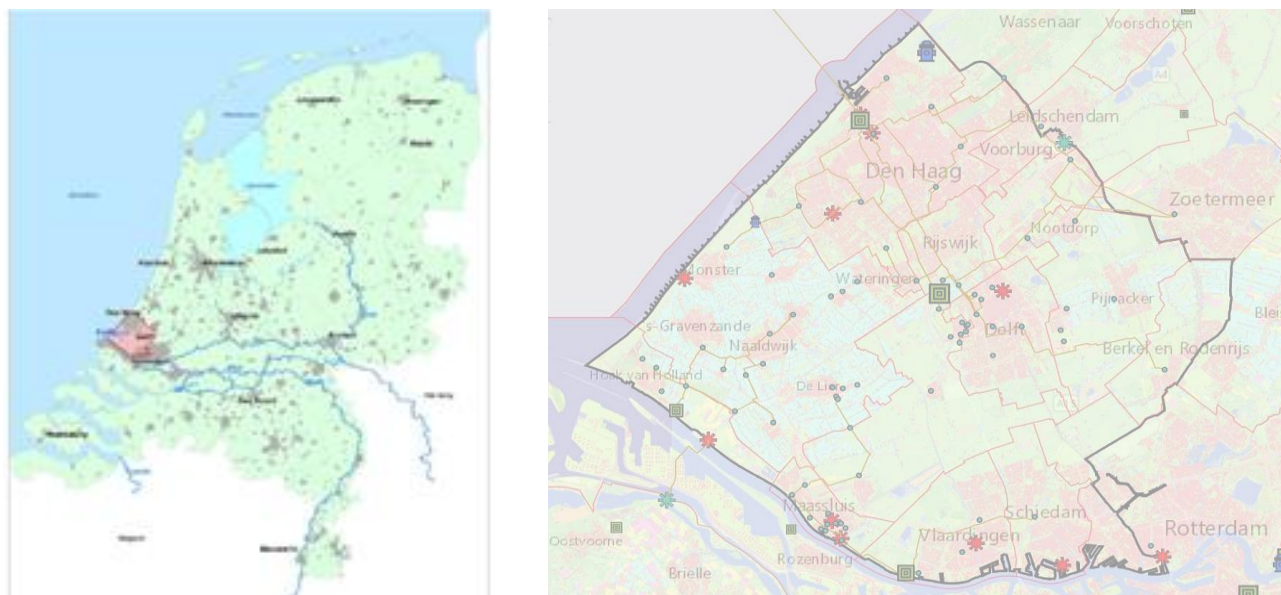

Figure 72 Location of Delfland in the Netherlands (left), along with a more detailed regional view (right).

The Delfland¹ region lies in the western part of the most populated province in the Netherlands, the province of South Holland. Spanning a total area of c. 410 km², Delfland features urban and industrial areas of high density, as well as extensive greenhouse complexes that are mainly used for horticulture. Within NextGen, this area is referred to as Delfland (Figure 72), which has the same extents as the area of the Water Board of Delfland and contains the Westland region (a rural area in the southwestern part mostly with greenhouse complexes), along with part of the cities of Rotterdam and The Hague (urban areas). Figure 72 right includes the regional extents (black line), urban areas (red) and horticulture areas (blue). Delfland is one of the most populated spaces in the Netherlands and thus the world, with approximately 1.2 million inhabitants living and working in a total of 450,000-520,000 households and 40,000 businesses and industries (Dijcker et al., 2017; *Dutch Waterboard Delfland Website*, 2020). Evidently, smarter urban water (re)use options have a potentially strong impact in this dense area, as the province aims at strategies towards wiser, more circular water management in the coming decades, in light of challenges such as a variable climate and a changing population (Dijcker et al., 2017). The region is furthermore renowned for its intensive glasshouse horticulture, with multiple horticulture companies using between 3,000 – 10,000 m³/ha-year, depending on the crops grown.

¹ In older mentions of this demo case, the name “Westland region” was used to outline the same area. This name is equivalent to Delfland, which better reflects the entirety of the region, as Westland is the subregion containing mostly horticulture.



Due to their intensive demands, horticulture companies in Delfland currently rely on rainwater harvesting through (shallow) water basins for coverage. With an average volume capacity of $800 \text{ m}^3/\text{ha}$, this system is widely used but cannot cover demand peaks (particularly in the summer), as the storage capacity is low due to space limitations. This results in a mean annual irrigation water demand deficit that needs to be covered from other sources. Additional freshwater for irrigation is provided from brackish/saline groundwater extraction and desalination by reverse osmosis. This currently used practice is unsustainable, as it leads to net withdrawals from the aquifer that are associated with further salinization and, in part of the area, with subsidence. Moreover, desalination produces a residual flow of saltier concentrate (also referred to as brine) that has detrimental effects on the environment (Ahmed & Anwar, 2012) and that is currently discharged by infiltration into the deeper ground. As a more sustainable alternative, infiltration of excess rainwater from some greenhouses with low demands to deeper layers (and reuse via pumping during dry months) has been proposed, through a system of infiltration wells that are used to create a balance between infiltration into and extraction from a groundwater system. This system has been studied in detail (Stofberg et al., 2021; Stofberg & Zuurbier, 2018) and is known as *waterbanking*. Using a waterbanking system, the cost related to rainwater infiltration is shared between the parties that mainly benefit from groundwater withdrawals, i.e. the users that have the highest demands due to their more intensive crop types. Waterbanking is a form of Aquifer Storage and Recovery (ASR), but it is different than typical ASR systems in that the infiltration and extraction points need not be in the same aquifer zone; what matters is that the net regional balance to the aquifer is restored.

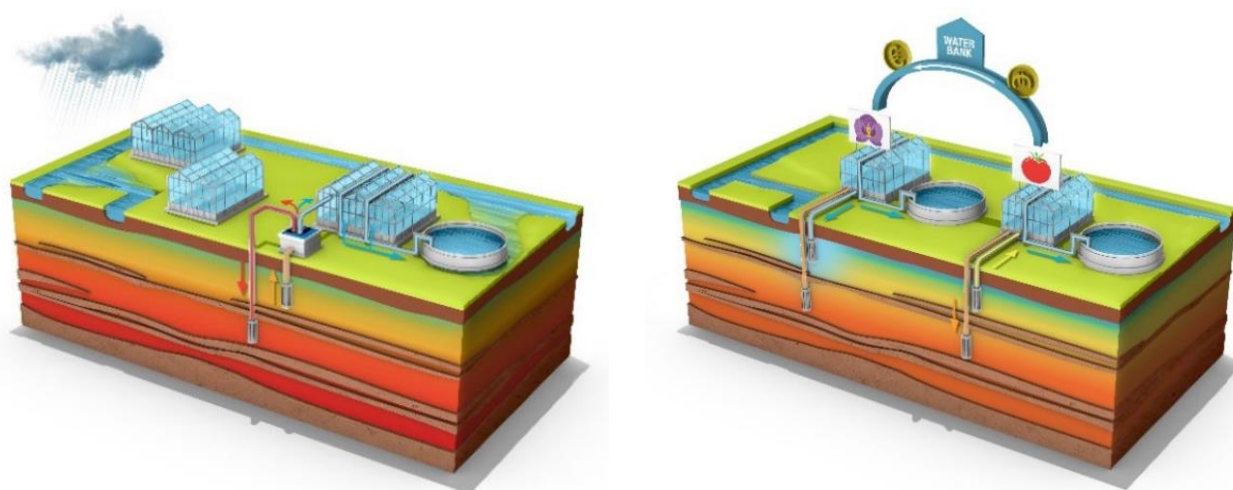

Figure 73 The current water management system in horticulture (left), and a more sustainable alternative (right)

Figure 73 shows the current water management system in horticulture (left), relying on rainwater harvesting in shallow basins and pumping and desalination of brackish groundwater. On the right is a more sustainable alternative, the water banking system, proposes a system where some horticultural users infiltrate rainwater to deeper layers, while other rely on groundwater extractions, with a zero net effect on the aquifer.

There are other dimensions in the water-energy-nutrient nexus for Westland (for instance, nutrient recovery in the regional wastewater treatment plants (WWTP) or within the horticulture complexes, as well as the potential for using energy waste (from industrial areas)



to power intensive horticulture consumption, but these are not explored in the context of D2.3. The corresponding UWOT model focuses on the integrated water management system that includes urban, peri-urban and rural (horticulture) uses, exploring their interplay and potential for circularity through a set of interventions.

6.1. Data preparation

To prepare the data inputs from UWOT, raw data from different sources are first collected, evaluated, and inserted into one common database that includes spatial (GIS) files, as well as tabular (MS Excel) data. As an integrated urban-rural water system model, the data requirements include urban system data (urban coverage and uses, household occupancy and consumption, rainfall data, past recorded demands and WWTP effluent timeseries) as well as rural system data (rainfall and evaporation data, greenhouse units, greenhouse demand consumptions, technical characteristics of the horticulture roofs and basins). The data was obtained and collected from different sources (both open-source and proprietary) prior to the modelling exercise. A summary of the collected data along with the corresponding data sources is summarized in Table 29.

Table 29 Assessment of the land uses in the region of Westland.

<i>Data Needs</i>	<i>Sources</i>
Number of households, residential distribution (houses/apartments)	cbs.nl (Province Zuid-Holland), hhdelfland.nl (Delfland Water Board), using latest annual data
Household consumption (water appliance uses and frequencies of use)	national statistics (WaterStatistieken), Past KWR consultancy on Dutch settings (SUPERLOCAL)
Rainfall (daily time-series)	KNMI
Temperature (daily time-series)	
Spatial characteristics of urban areas (pervious/impervious land use)	hdddelfland.nl (Delfland Water Board) pdok.nl (Dutch open datasets) zuid-holland.nl (Province Zuid-Holland) CORINE land cover (EU dataset)
Treatment capacity and storage of typical decentralized urban systems (RWH/GWR) at neighbourhood level	Past KWR consultancy on Dutch settings (SUPERLOCAL)
Spatial characteristics of rural areas Number of greenhouses Greenhouse demands (daily time-series)	Past KWR projects on horticulture management (COASTAR)
Technical characteristics of shallow basins	Past KWR projects on horticulture management (COASTAR)
Technical characteristics of water banking system	

The collected data are then used for model preparation through the following steps:



1. Collection of all spatial information about Westland in GIS files and formulation of a geodatabase in QGIS (Figure 74). This geodatabase holds all spatial layers of the model and is primarily used for tasks such as measuring areas, estimating urban and rural land uses etc.
2. Pairing of this geodatabase with a spreadsheet that is also able to host the UWOT model output, thus bringing model input and output to a common database. This is called the reference database for the UWOT model (see Figure 74).
3. Insertion of the data in the UWOT model, which is then used for simulating the combined urban-rural water system (URWS) as a whole. The simulation timeframe is set to ten years, with a daily time step, thus comprising of 3650 steps and is typically executed in seconds. Following the simulation process, the produced model outputs are extracted (either manually or through the UWOT API, depending on the use case and scenario). The UWOT model is provided as an executable file in a Windows 10 operating system (64-bits) and is mainly operated through its Graphical User Interface (GUI).
4. Supplementary data analysis tasks (e.g. downsampling demand time series, checks for missing values etc.) are done using the Python language (version 3.6).

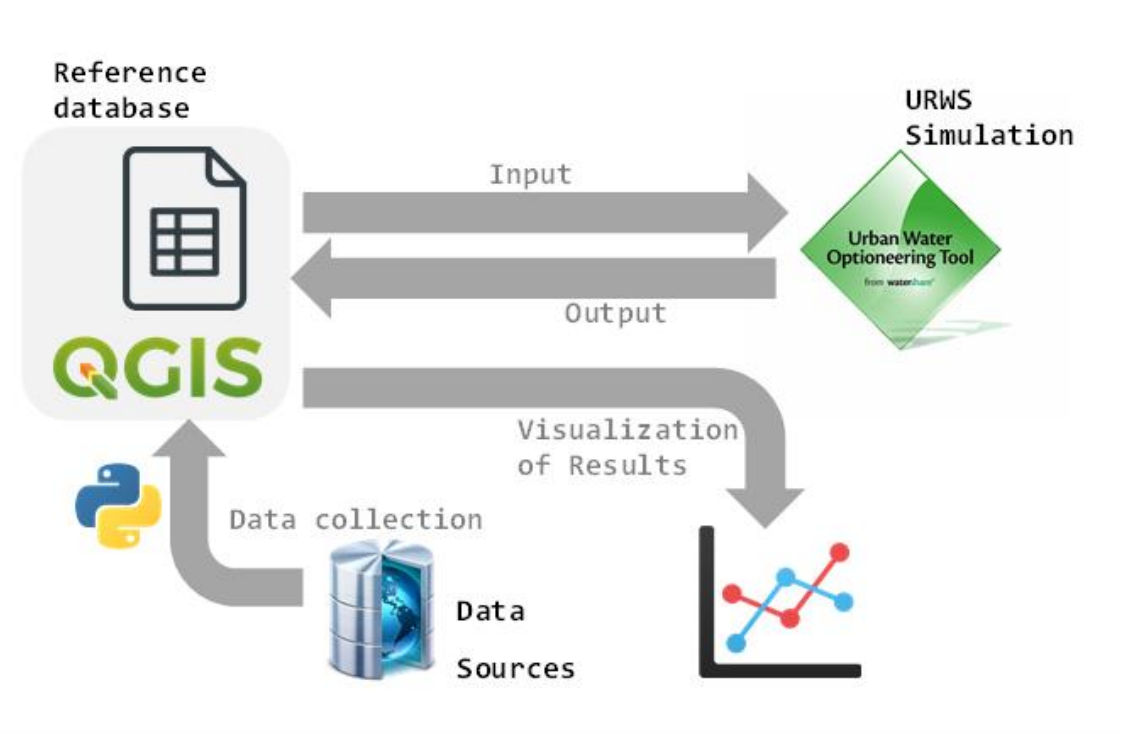

Figure 74 Schematic of the data preparation scheme that utilizes a reference database for model input and output.

6.2. UWOT baseline model

6.2.1. UWOT baseline model setup (BAU)

To calculate runoff, UWOT requires pervious and impervious surfaces (area in km²). This is calculated for Westland by employing the CORINE dataset (Büttner et al., 2004), an open source spatial (raster) database of multiple land use classes that includes urban uses, rural uses and other surface bodies (e.g. open water, landfills etc.). The latest operational CORINE raster data (year of reference 2020) are inserted into the project geodatabase (see Figure 75) and aggregated into zones that can be modelled with UWOT (Table 30), before being translated into relevant UWOT components (pervious and impervious areas). As a validation step of this process, the total area from the CORINE dataset is calculated, amounting to 405.51 km², a deviation² of 1.1% from the reference area of c. 410 km², which is itself a rounded approximation. The housing area of 141.82 km² is then divided further into: (a.) the rooftop area of houses. (b.) pervious neighbourhood area (gardens, yards), and (c.) impervious neighbourhood areas (pavements, roads, built yards) (85.1 km² / 28.4 km² / 28.4 km²), based on a comparison of a random sample of CORINE raster cells (with a resolution of 100m x 100m) against visual imagery in the cities of reference (the Hague, Delft, Rotterdam). An example of this comparison is shown in Figure 75. This further disaggregation is done to able the calculation of the surface area that can be used for rainwater harvesting scenarios at a neighbourhood level.

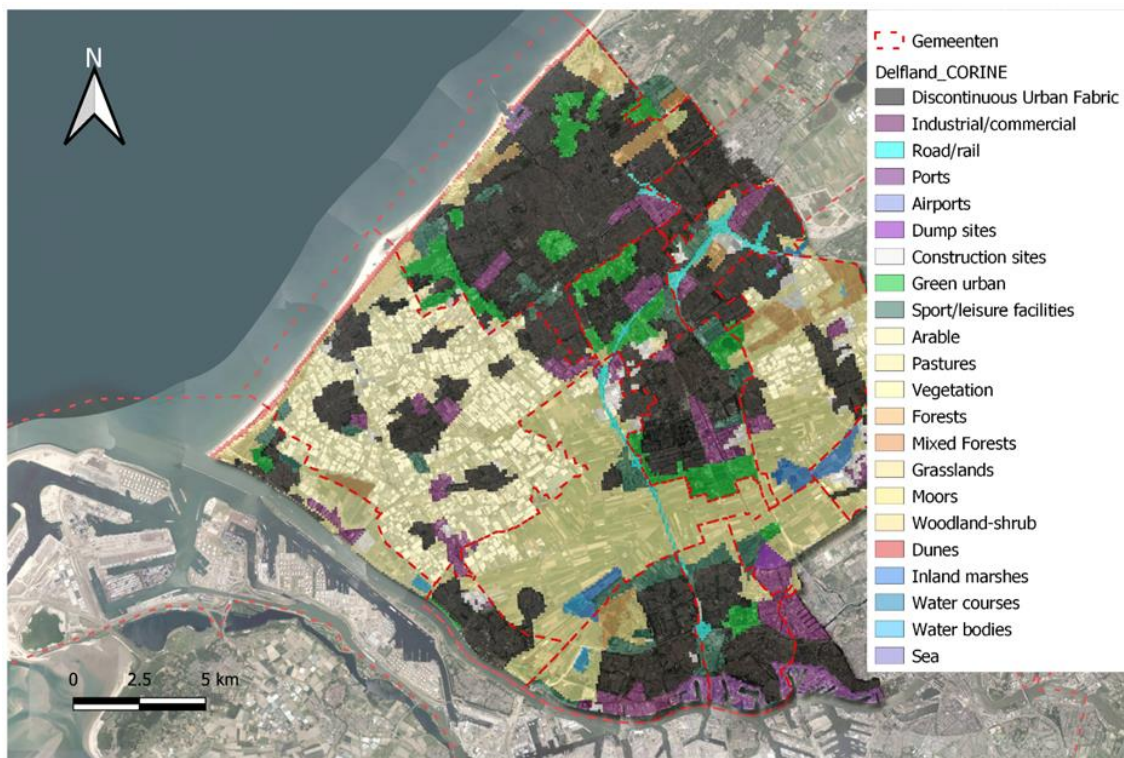

Figure 75 Overview of the Delfland geodatabase that was used to prepare the UWOT model. The different CORINE land use classes are visible against the orthophoto of the area, along with the municipality (gemeente) borders with red dotted lines.

² The deviation is within reasonable limits, given cropping errors in the CORINE raster map (where boundary raster cells may be cut off), as well as the fact that the estimation of 410 km² is an approximation.

Table 30 Assessment of the land uses in the region of Westland.

Land use	Value	Percentage
	km ²	
Housing	141.82	35.0%
Industry and Commerce	22.09	5.4%
Roads	4.38	1.1%
Urban - other	14.06	3.5%
Green urban	20.32	5.0%
Sport and leisure facilities	17.4	4.3%
Agricultural land (incl. horticulture)	156.45	38.6%
Forest	10.22	2.5%
Rural - other	9.88	2.4%
Dunes, sand	3.33	0.8%
Water	5.56	1.4%
Total areas	405.51	



Figure 76 Further disaggregation of CORINE housing cells in rooftops, public pervious and public impervious areas.

With regards to the rural domain (horticulture), UWOT employs horticulture data collected from past KWR reports (Stofberg et al., 2021; Stofberg & Zuurbier, 2018) that includes: (a) horticulture areas, crop types and the corresponding demands, (b.) information about shallow basin characteristics (capacity per hectare, depth). The horticulture demands are provided in a fine scale (per horticulture company, daily) for three crop categories (low, middle, and high, depending on their demand needs). In UWOT, the greenhouse (horticulture) system is modelled with a lumped approach, assuming that any company behaves as a characteristic Horticulture Unit (HU) that has specific demands (which vary seasonally) and that features a shallow basin system that stores surface water. Given the different crop distributions, the three demand categories are then used to weigh demands into one equivalent, characteristic

demand pattern for a single HU in UWOT³. This is evident in the upper panel (a) of Figure 77, where the conventional HUs, i.e., the group of HUs that feature only shallow basins, are shown as UWOT components through the software interface. This group of HUs is complemented by an (arbitrary) group of HUs that connect to an infiltration well and are thus able to infiltrate excess rainwater into deeper layers, which can be seen in panel (b) of Figure 77. The latter group is employed in the subset of scenarios that feature water banking.

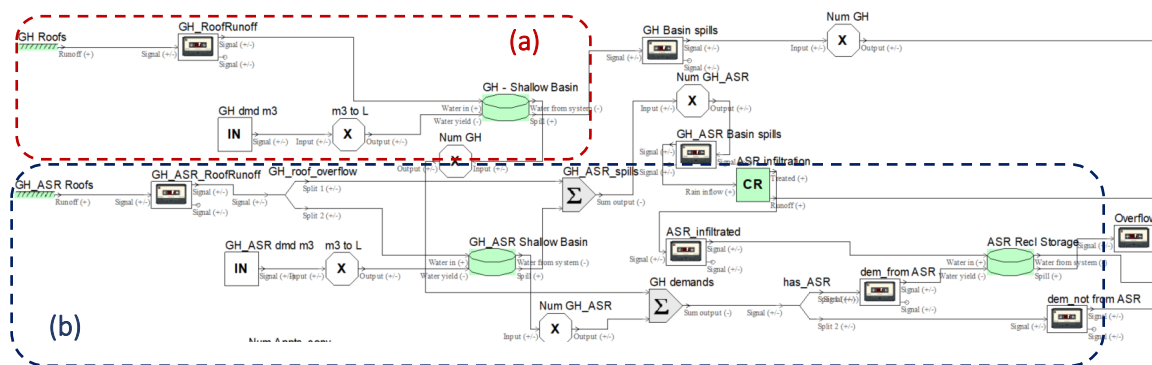

Figure 77 Schematic of the horticulture system components in UWOT.

Each group can have an arbitrary number of units, which means that the same horticulture components system (topology) of Figure 77 can be used to model waterbanking scenarios as well, besides the baseline (conventional system). The division of units follows the recommendations of previous KWR sectoral models on horticulture (Stofberg et al., 2021) and is shown in Table 30, along with the equivalent HU demand categories, which are based on different characteristic crop types.

The entirety of the model as an integrated, regional Urban-Rural Water System (URWS) can be seen in Figure 78, where different parts of the regional water cycle are highlighted with different colours. The upper panel (a) features all horticulture components, which are described in more detail in Figure 77. Panels (b) and (c) show the residential (neighbourhood) units (RU) that feature two household types, detached households (with gardens) and apartments. These residential units are modelled from the household (appliance) level and up, in a similar fashion to previous KWR consultancy studies on circular neighbourhood-level interventions (Bouziotas et al., 2019). The left RU template (panel (b)) features conventional households, i.e. households that do not feature any circular water intervention, such as Rainwater Harvesting (RWH) or Greywater Recycling (GWR). The right RU template (panel (c)) features households with circular water interventions at the neighbourhood level, i.e., decentralised RWH and GWR systems that are activated in certain redesign scenarios and are described in more detail in Section 6.3. Panel (d) features non-household urban runoff components, including urban green spaces. Finally, panel (e) includes components on centralized wastewater (WW) treatment, which models the (partially) combined sewer system in Delfland that receives wastewater as well as part of the stormwater.

³ Compared to horticulture-specific, sectoral water cycle models from previous studies (e.g. COASTAR), UWOT is not able to resolve all HU variabilities in fine scale and has to rely on one characteristic HU type. The implications of this simplification are explored in the results section.



6.2.2. Validation of the baseline setup

Prior to demonstrating the results of the model in the re-designed system of Delfland, it is important to validate modelling results against third-party datasets. This is possible for the scenario of BAU seen in Figure 78, as it represents the present-day reality that can be checked against real information collected from the water system. Validation is generally possible in two different ways (Bouziotas et al., 2019):

- With the use of measurements at the system level, where possible. These measurements can be, for instance, measurements of urban water provisions by the two water utilities⁴ of Delfland.
- With cross-model validation, i.e. validation against the output of third-party water cycle models with the same application domain. This can be done against simple water cycle models that have been used for the entire region (e.g., (Dijcker et al., 2017)), or against more finely-defined, sectoral models that target a specific part of the water cycle, such as models focusing on horticulture (Stofberg et al., 2021).

In the context of this report and owing to the complexity of the model, both methods are used to test UWOT output. Real data measurements, obtained from the past KWR study of WaterFabriek (Krajenbrink et al., 2021), are used to evaluate model performance in two cases:

- a) Recent influx measurements from all wastewater treatment plants (WWTPs) are used to evaluate the modelled effluent in the baseline scenario (BAU).
- b) Data from recent water provisions in Delfland (regional, where available) are employed to validate the residential and non-residential water consumptions modelled in the baseline scenario of UWOT (BAU).

Finally, cross-model validation is performed at cases where there are similar results across models, both in the baseline (BAU) scenario as well as in system redesigns. For instance, in the domain of horticulture, the results of the COASTAR project (Stofberg et al., 2021; Stofberg & Zuurbier, 2018) can be employed to compare both present-day reality (baseline conditions) as well as redesigns that include waterbanking (and are noted in the COASTAR reports as the *waterbank basis* scenario). As models are simplifications of reality and feature multiple (often uncalibrated, due to data unavailability) assumptions, neither model offers a definitive 'ground truth' to check validity, but their comparison provides a way to check different logical processes that allows the discovery of model errors and limitations.

With regards to wastewater, influx data from the four (4) different Wastewater Treatment Plants (WWTP) of the region have been obtained through WaterFabriek and have been aggregated to reflect the scale of the UWOT model. The aggregate influx data range from 2015 to 2018 and have an annual average of 129.57 hm³/year (see Table 31). This quantity is very close to the one presented by other studies and models, for instance 130.0 hm³/year in the Defland Circulaire report (Dijcker et al., 2017) and a range of 123-130 hm³/year in the WaterFabriek model (Krajenbrink et al., 2021), depending on how dry the year of reference is. In the UWOT BAU case, the generated wastewater per year varies in the range of 116.74 hm³/year-135.57 hm³/year, with an average value of 126.2 hm³/year and a standard deviation of 5.8 hm³/year. The modelled annual average has a deviation of 2.67% from the historical value, which highlights good accuracy, given that UWOT models demand and wastewater from the household scale (where regional data on occupancy, regional patterns etc. are largely unknown) and up.

⁴ As an area, Delfland is serviced by two water utilities, which have service areas that surpass the extent of this regional study. As such, only District Meter Areas (DMAs) that lie within Delfland are selected for the validation process.



Table 31 Modelled wastewater results against other data sources.

WW data for Delfland	
Historical effluent 2015 [hm ³ /year]	129.9
Historical effluent 2016 [hm ³ /year]	129.5
Historical effluent 2017 [hm ³ /year]	135.9
Historical effluent 2018 [hm ³ /year]	122.9
Average historical value [hm ³ /year]	129.6
Delfland Circulaire report [hm ³ /year]	130.0
WaterFabriek report [hm ³ /year]	123.0-130.0
UWOT model [hm ³ /year]	126.19

With regards to drinking water demands at the centralised (water utility) level, data from the two water utilities⁵ that operate in Delfland have been obtained. These data include: (a.) the annual serviced water in 2018 and 2019, for both utilities, and (b.) the distribution of serviced water across regular (individual) and commercial (i.e., industrial and large corporate) clients, for one utility only. Table 32 compares these data to the UWOT output (10 years of simulation, daily time step, aggregated), where one observes a generally good agreement in both residential (deviation of 5.0%) and non-residential (2.5%) water. The larger deviation in residential water is reasonable, as the distribution in regular and commercial demands is based on data from one utility only. The distribution of serviced water in residential and other (industrial, commercial) uses can be seen in Figure 79 where, again, UWOT follows the general pattern with good accuracy.

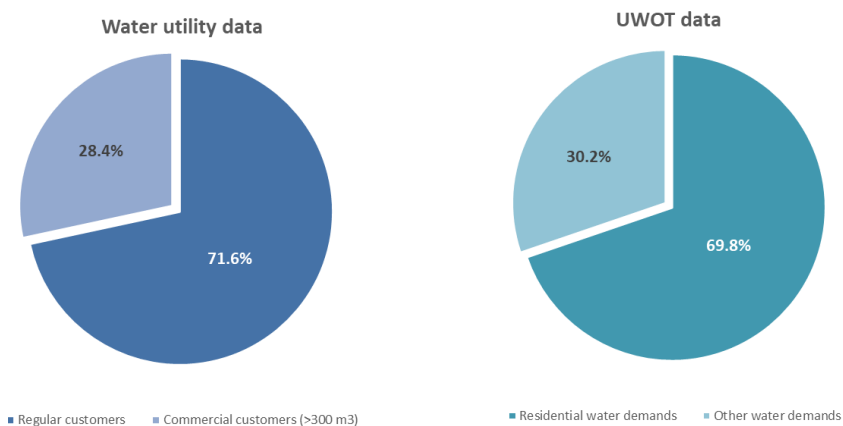

Figure 79 Observed and modelled distribution of DW services.

⁵ To protect the utility anonymity, the data is presented in an aggregate fashion and anonymized.



Table 32 Modelled drinking water results against other data sources.

Water utility data for Delfland	
Total demands 2018 [hm ³ /year]	79.38
Total demands 2019 [hm ³ /year]	79.36
Total demands - average [hm ³ /year]	79.37
Residential demands (extrapolated from the distribution of one utility) [hm ³ /year]	56.85
UWOT output	
Total demands - average [hm ³ /year]	77.42
Residential demands [hm ³ /year]	54.01

With regards to horticulture, a cross-model validation is performed against past sectoral KWR reports that include horticulture models (Stofberg et al., 2021; Stofberg & Zuurbier, 2018), to evaluate the performance of the particular UWOT subsystem (see panel (a) of Figure 78). This comparison is viable, as both studies model the extent of Westland⁶ with regards to horticulture, a total number of 1291 units. The resulting flows from UWOT fall very close to the ones modelled in the waterbanking study baseline, with deviations in every case being less than 4%. UWOT is able to model the rainfall falling on roofs, as well as the overflow from the surface basins to the outlet, with good accuracy. A relatively larger but still low deviation (3.8%) is seen in the greenhouse demand deficit that must be covered by the groundwater annually; this is likely caused by the lower granularity of UWOT in the horticulture domain, as an integrated model with one equivalent HU.

Table 33 Results of the horticulture system in BAU against other data sources.

Description	Value in COASTAR model	Value in UWOT model
Number of greenhouse (GH) units	1291	1291
Rainfall on GH roofs [hm ³ /year]	21.6	21.26
GH demand deficit, covered by RO [hm ³ /year]	3.7	3.84
Overflow to surface water [hm ³ /year]	4.7	4.72

6.3. Scenarios analysis

6.3.1. Preparation of the circular redesign scenarios

In the case of Delfland, redesigning the system means to propose an alternative setup of decentralised or centralised water management interventions, at any or multiple of the included model domains (drinking water, runoff management, wastewater, and horticulture water management), in order to change the currently predominantly linear water management model to a more circular one. Such alternative setups are envisioned to be the product of:

⁶ Delfland also includes a small additional area with horticulture in Oostland, but it is relatively smaller compared to the majority of greenhouse units that are in Westland and with very limited data (Krajenbrink et al., 2021). It is excluded from this study in a similar manner to other horticulture studies in the region, but – since the model is made with generic quantities of HUs - can be added in future iterations of the model, if more data becomes available.



- consistent policy changes, that translate to WM interventions at the household, neighbourhood, or regional scale. Such a policy change is, for instance, to actively support the uptake of rainwater harvesting (RWH) systems at neighbourhoods or in urban parks.
- behavioural or cultural shifts, for instance resulting from an increased level of customer awareness. An example of such a shift is the introduction of water-saving devices in houses, for instance due to a larger portion of customers being water-aware.
- upscaling a promising WM technology, such as Aquifer Storage and Recovery (ASR) and waterbanking to a regional level. Multiple pilots exist for promising technologies in Delfland, such as small waterbanking clusters in Westland and wastewater reuse units for greenhouse horticulture in Nieuwe Waterweg. It would be thus worthwhile to explore upscaled scenarios where these pilots become regionally important.
- materialising a regional vision, i.e. a cross-sectoral master planning for the region that is linked to an integrated water management theme, such as climate change proofing, achieving circularity, or becoming water-smart. Regional visions exist for Delfland (Dijcker et al., 2017) and have been used as building blocks for elements of the proposed redesign scenarios.

Having in mind the aforementioned aspects of regional redesign, a number of circular redesign scenarios have been schematised and discussed with regional stakeholders via one of the NextGen project Communities of Practice (CoP) for Westland, held in 2021. These scenarios are assumed to be redesign visions of varying ambition and technological complexity, that could be materialised by 2030, and that can link to the following two domains (i.e. themes):

- **rainproofing**, which focuses on the use of rainwater as a resource and on actively storing and (re)using rainwater within the region, so as to lessen the impact of flooding in (potentially) more extreme futures, as well as to increase the efficiency with which rainwater is utilised. In the current (BAU) situation, RW harvesting and use is limited to the use of shallow basins for horticulture.
- **water-awareness and circularity**⁷, which focuses on circular interventions in the residential (urban) domain, building from the household level up. In cases of higher complexity, this domain also features household demand management measures and, eventually, links urban flows to rural (horticulture) flows through WW reuse.

⁷ Both themes relate to a circular future, as they introduce reduce-reuse-recycle loops in water management. The term 'circularity' is used in the context of the second theme to outline the circular nature of household interventions (RWH/GWR).



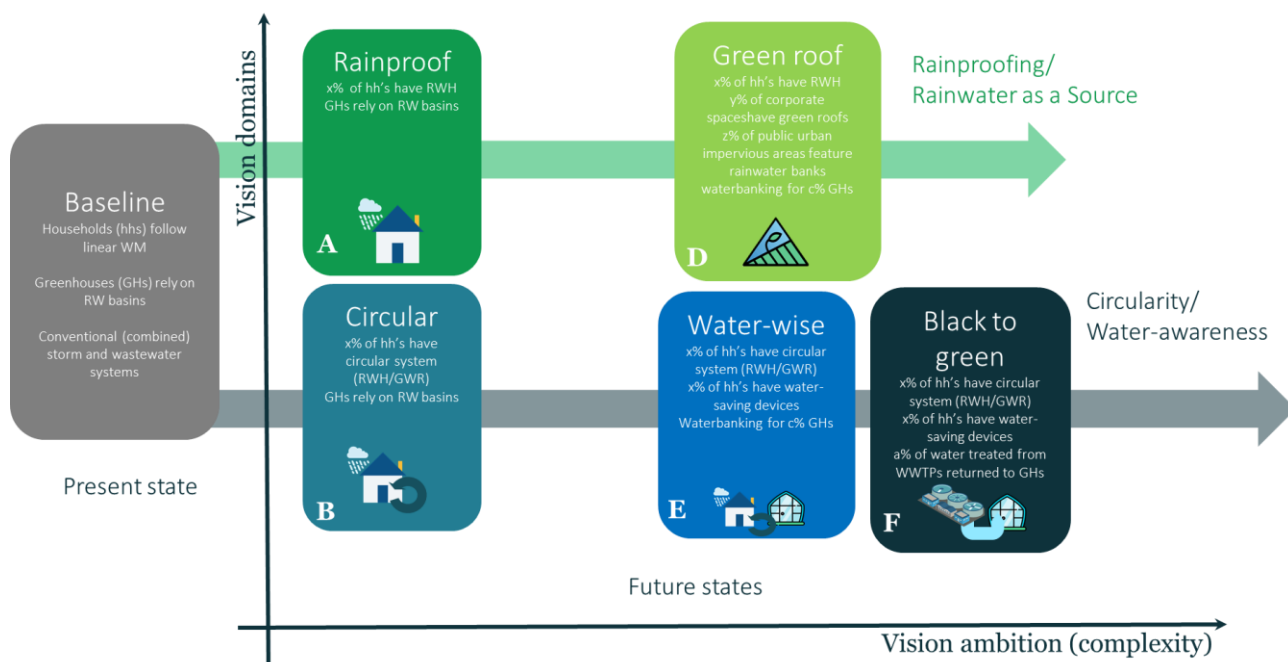

Figure 80 Mapping of the five initial redesign scenarios for Delfland.

As a preliminary step, five (5) redesign scenarios across these two themes are created and shared with the CoP participants. These redesign scenarios have varying complexity, starting from simpler interventions at specific parts of the regional water cycle and expand to more complex changes across multiple water cycle domains. The scenarios are:

1. The rainproof (abbr. RAINP) scenario, where Rainwater Harvesting (RWH) is introduced to households in Delfland, for instance through a supporting, enabling policy. As a result, a goal is achieved in 2030 that x% of households have a RWH system installed, which shares a storage unit at neighbourhood level⁸.
2. The green roof (abbr. GREEN) scenario, where RWH is extended beyond the household level and includes regional-scale interventions as well, such as green roofs in some (y%) office spaces and certain public impervious areas (z%), as well as a waterbanking system for green houses in Westland, where c greenhouse units infiltrate water to deeper groundwater layers.
3. The circular (abbr. CIRC) scenario, where circular technologies are introduced to a percentage of households in Delfland. Circularity lies in the reuse of household effluent (greywater, GWR), as well as the capturing of rainwater (RWH), in a hybrid RWH-GWR system installed at neighbourhood level. As a results, x% of households have a hybrid RWH/GWR system installed.
4. The waterwise (abbr. WATWISE) scenario, where these circular household technologies are complemented by active demand reduction measures (DRMs) at the household level, with the introduction of water-saving devices. Moreover, waterbanking is also employed as a circular intervention for greenhouse units in the rural domain.
5. The black to green (abbr. WW2G) scenario, where urban circularity technologies (including demand reduction options) are paired with the (re)use of urban wastewater effluent as a resource for horticulture in the region. This means that, by 2030, a% of the water treated

⁸ This design is generally more cost-efficient and thus possible due to an economy of scale, compared to per-house RWH units.



from one of the regional WWTPs will be reused to cover the greenhouse demands and increase the sustainability of the greenhouses.

Which scenenario is preferred?

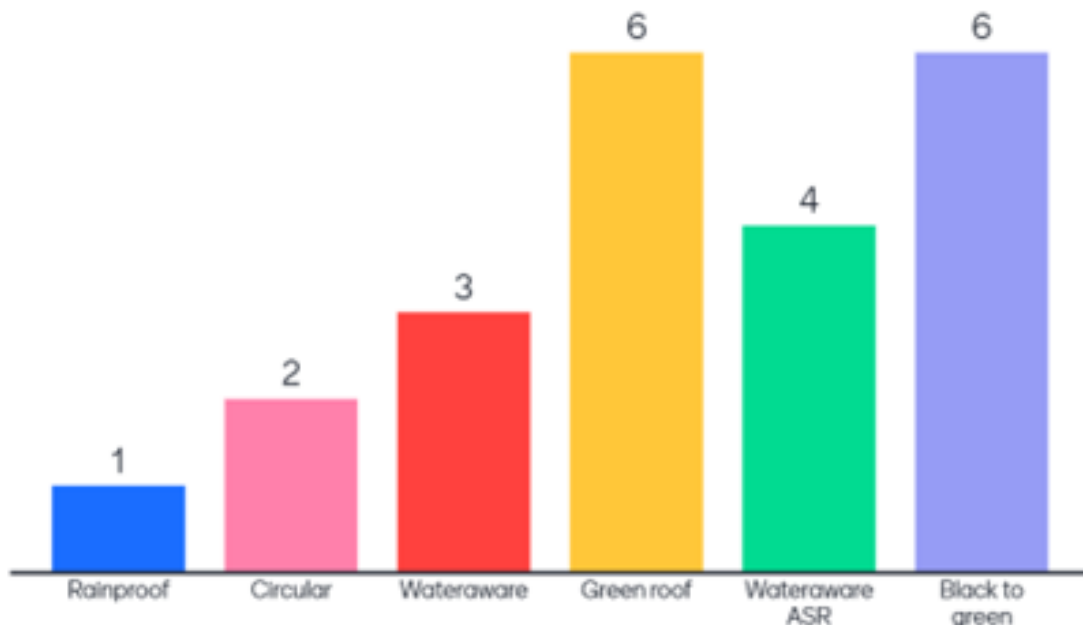

Figure 81 Results of the redesign scenario evaluated by the 2nd Delfland CoP participants.

An overview of these five redesign scenarios is given in Figure 81, scaled against the vision ambition and complexity for each redesign. As part of the 2nd NextGen Delfland CoP (held in 2021), these scenarios have been evaluated by the participating regional stakeholders in terms of practicality and interest with a voting process. The results of this evaluation⁹, seen in Figure 82, show that stakeholders find more complex redesign visions more compelling, with their largest interest focusing on the Green Roof and Black to Green redesigns. Both vision domains are thus covered in terms of interest, but the simpler redesign versions of RAINP and CIRC were not found as interesting. The use of waterbanking for horticulture, along with more water-aware measures (WATWISE), comes in the third place. As a result of this evaluation, it was decided to progress with the three of the most complex redesign scenarios (GREEN, WATWISE, WW2G); the CIRC scenario was also included as a first step to model scenarios of higher complexity, and since no other modeling study for Delfland currently covers urban circular intervention scenarios. The least voted option of RAINP was excluded from the modeling process.

Finally, as part of the participatory redesign evaluation process, the parameterisation of the scenarios has been discussed. The aforementioned quantities that can be reached by 2030 (e.g., x% of households with RWH systems installed) have to reflect the ambition of regional stakeholders and governance, but are also limited by practical factors such as the available capital for investment, legislation, water quality restrictions etc. The discussion of parameters with the stakeholders led to the conclusion that a range of 15%-30% for these parameters is a good tradeoff between high

⁹ The figure shows six variants instead of five, as the water-wise (WATWISE) redesign was presented to stakeholders both with and without horticulture waterbanking ('Wateraware' and 'Wateraware ASR').



ambition and applicability; the parameters seen in Table 34 were thus selected as quantitative targets of each redesign vision. The knowledge obtained from other KWR studies was used as well; for instance, for each scenario that includes waterbanking for horticulture, the guidelines and scenarios from the COASTAR waterbanking study are employed (Stofberg et al., 2021; Stofberg & Zuurbier, 2018), which estimate that the use of 600 HUs for infiltration is plausible. For the scenario that includes WW reuse for horticulture, the findings of the waterfabriek STOWA study are used (Krajenbrink et al., 2021), which indicate that 5% of the WW effluent annually from selected large WWTPs in the area (Nieuwe Waterweg and Harnaschpolder, whose effluent totals 78 hm³) is a realistic target for an upscaled reuse system.

Table 34 Overview of the redesign scenarios parameterization

Redesign scenario	Parameter	Unit	Value	Comments
CIRC	x_1 % of houses that are circular	%	20.0%	
	x_2 % of apartments that are circular	%	25.0%	¹
WATWISE	x_1 % of houses that are circular	%	20.0%	
	x_2 % of apartments that are circular	%	25.0%	
	x_3 % of houses that have demand reduction measures	%	20.0%	²
	x_4 % of apartments that have demand reduction measures	%	25.0%	
	x_5 % demand reduction for office spaces	%	20.0%	
	Number of GHs with infiltration c	-	600	
	Number of conventional GHs	-	691	
GREEN	x_1 % of houses that are circular	%	20.0%	
	x_2 % of apartments that are circular	%	25.0%	
	y % of the commercial/industrial surface converted to green roofs	%	30.0%	
	z % of public impervious spaces converted to green spaces	%	30.0%	
	Number of GHs with infiltration c	-	600	
	Number of conventional GHs	-	691	
WW2G	x_1 % of houses that are circular	%	20.0%	
	x_2 % of apartments that are circular	%	25.0%	
	x_3 % of houses that have demand reduction measures	%	20.0%	
	x_4 % of apartments that have demand reduction measures	%	25.0%	
	x_5 % demand reduction for office spaces	%	20.0%	
	a % of WW effluent gets reused	%	5.0%	³

1 It is generally easier to introduce household interventions in stacks of apartments, hence the increased uptake

2 As a limitation to the model, two house types are considered (conventional and circular), each with a household and apartment template. As such there is the topological limitation that $x_1=x_3$ and $x_2=x_4$.



- 3 This refers to the effluent capacity of one large WWTP closer to the horticulture area.



6.3.2. UWOT circular redesign models setup

The selected circular redesign scenarios (CIRC, WATWISE, WW2G, GREEN) alter, in different ways, the UWOT model components of the conventional water system (see Figure 78) and, on occasion, introduce new loops - and thus new components - to the topology that reflects the regional water management strategy. Some of the circularity interventions that are discussed in Section 5.4.1 are already built in the BAU topology seen in Figure 78; for instance, the circular houses and apartments in the CIRC scenario can be readily altered by activating residential units in panel (c) of Figure 78 (while simultaneously reducing the number of conventional units in panel (b)), while HUs that are able to infiltrate water (in any scenarios that require waterbanking, such as WATWISE) are able to be activated through panel (a) in Figure 78.

Two of the selected scenarios (GREEN and WW2G) introduce new components in UWOT and thus require alterations of the topology to reflect new interventions. GREEN introduces green roofs (and the corresponding new components) as a supplement to specific surfaces (such as office spaces and public impervious areas), thus altering panel (d) of the BAU topology. These alterations are noted in area (f) of Figure 82. Moreover, the WW2G scenario introduces a new loop from WW that is generated in panel (e) of Figure 78 to cover horticulture unit demands, seen in panel (c). The resulting new topology can be seen in Figure 83, with an extra loop introduced in panel (f) to reuse WW from the WWTP to the horticulture units, through a Sewer Mining component (i.e. with a set capacity per day, set to 5% of 78 hm³).

6.3.3. Redesign results at the coarse scale

Following the completion of different UWOT schematisations – both for the present-day, BAU case, and the alternative proposed redesign scenarios – simulation is executed to obtain results at the fine (i.e. daily) time scale. The UWOT model is forced with historical daily rainfall timeseries obtained from KNMI (2008-2018¹⁰), using the station with the closest proximity to Delfland with adequate data length that could be found in the KNMI datasets (station of Rotterdam). For the scenario that includes green roofs (GREEN), this data is supplemented by timeseries of minimum and maximum daily surface temperature for the same decadal timeframe, as temperature is a requirement for the Green Roof component to calculate evapotranspiration. The horticulture and non-residential demands are also generated in Python and inserted as decadal time-series of daily time step, in order to represent the seasonality seen in the historical data. As explained in Section 6.2, the horticulture units (HUs) modelled in UWOT have an equivalent unit demand (in m³/day) that is characteristic of the three different crop types and their distribution in the existing system. The rest of the forcing parameters (occupancy, appliance water usage, surface areas, shallow basin attributes etc.) are constant and assimilated from different sources, as seen in Table 29. Each single simulation is run with UWOT v.2.00.0.2 in x64-systems (Microsoft Windows 10, 8.0 GB of RAM), with a runtime in the range of 20-30 seconds. No errors are reported from the software during the simulation of each topology, indicating that all components are connected and that the water balance is closed. The generated model data are then inserted in the reference database (see Section 6.2) and are able to be further edited, aggregated and visualized with the use of spreadsheet software and other data analysis tools.

As the UWOT model provides output at a daily timestep, the results can be analysed at a coarse or fine scale. At a coarse scale, one may aggregate to a monthly, seasonal or annual scale and obtain flows at different parts of the URWS, for instance in hm³/month or hm³/year. Since the model is integrated and includes multiple facets of the water cycle at both urban and rural domains, these flows can be collected at multiple points to form an extensive output dataset from tap to source and from the initial runoff surface to the outlet. One of the most efficient ways to visualize the model outcome at the coarse scale and at the system level is through the use of Sankey diagrams, which were originally developed to visualize flows in energy systems but have been also adapted for use in water systems (Curmi et al., 2013; Pronk et al., 2021). To represent system results at coarse scale, Sankey diagrams are developed to summarize the average annual water flows at multiple locations of the URWS in Delfland. The relative quantity of the water flows is expressed by the size of the arrows, while the different domains (stormwater (SW), drinking and clean water (DW) and wastewater (WW) are visualized as different hues (green, blue and brown correspondingly). All quantities depicted in the graphs are obtained directly from the model, so there might be reasonable deviations from the Sankey graphs of other studies about the same region (Dijcker et al., 2017) depending on the model assumptions (for instance, residential water usage, evapotranspiration rates, interception in rooftops etc.).

The results for the present-day, conventional water management can be seen in Figure 83. One may observe a predominantly linear management that propagates from source to tap or outlet in three main flow lines along two domains (urban and rural):

¹⁰ At the time of data assimilation, KNMI also had two extra years (2019 and 2020), but their zero value frequency was significant (>20%). It was thus decided to limit the dataset at the decadal time scale (2008-2018).



- a) drinking water treatment (77.4 hm³/year) that covers urban demands and is then converted to wastewater, processed to WWTPs and disposed of as sewage,
- b) rainfall in urban areas (equal to 194.3 hm³/year on average) that falls on built (impervious) and open (pervious) spaces, of which 49.3 hm³/year ends up in the (partly combined) sewer system and thus the WWTPs, while the rest is split between urban drainage (stormwater sewers) and water going in the surface (canal) system or infiltrating in deeper layers¹¹,
- c) rainfall in rural areas (equal to 163.7 hm³/year on average) that falls on open (pervious) spaces and on horticulture roofs, where it is directed to the shallow basin system and used to cover horticulture demands (17.6 hm³/year). An annual deficit of (on average) 3.8 hm³/year is obtained through brackish pumping and desalination with RO¹². The treated wastewater, stormwater overflows and seepage from rural areas all end to the regional outlet recipients of Nordsee and Het Scheur.

This largely linear water management scheme is changed to a more circular one when urban circular measures are introduced in the CIRC scenario (Figure 84), with loops of water recycling and reuse being introduced to the urban domain. The drinking water demands from the central utility have been reduced by 10.7% to 69.1 hm³/year as a portion of households has now become circular, featuring RWH systems that manage to capture 4.3 hm³/year annually and GWR systems that recycle 3.0 hm³/year. This results to less water entering the urban drainage systems and, along with the reduction in central water, results to less wastewater at the entry point of WWTPs. The horticulture system remains unchanged in this scenario, with all HUs using shallow basin units and thus having identical demands to the baseline scenario.

Circularity is further reinforced in the WATWISE scenario, which combines - besides residential interventions in the form of a hybrid RWH/GWR system – demand reduction measures in the form of water-saving appliances and the introduction of a waterbanking system for horticulture. One may now observe all circularity measures, in the form of:

- a) reduction, as the demand management measures further reduce the reliance of central drinking water to 62.6 hm³/year, in a more drastic reduction by 19.1% compared to the baseline,
- b) reusing, both in the urban and rural domains, as rainwater is efficiently captured and used, both directly in households (4.3 hm³/year) and through the waterbanking system (15.9 hm³/year in the shallow basins and 4.8 hm³/year infiltrating in deeper layers),
- c) recycling, with the internal household loop from the GWR system. Interestingly, owing to the demand reduction at the appliance scale, the yields of this loop are lower than the CIRC scenario to 2.4 hm³/year.

The introduction of waterbanking in the horticulture domain is also important, as it negates, for the most part, the deficits to 0.7 hm³/year¹³, with 4.8 hm³/year being sustainably covered by the infiltration system from the greenhouses that feature infiltration wells as well as a shallow basin (600/1291). The yield rate from the shallow basin system is now reduced to 15.9 hm³/year, due to

¹¹ UWOT does not explicitly model the surface water system or deeper (groundwater layers), so these parts of the water cycle are depicted with lower detail.

¹² This groundwater abstraction is displayed with a separate node to distinguish it from the reuse of groundwater with a waterbanking system, which is displayed in waterbanking scenarios such as Figure 85.

¹³ The COASTAR report that focuses on horticulture finds zero deficits for the same scenario, so UWOT is slightly more conservative with regards to the yields of the waterbanking system. This is discussed further in Section 5.4.4



the different operating rules of the shallow basins that now need to account for infiltration – and reserve some space for flood protection – as per the suggestions of horticulture studies.

A different vision of circularity can be seen in the GREEN scenario (Figure 86), which combines more substantial RWH for households in combination with green roofs for a percentage of urban spaces. Urban demands are reduced by 11.3% to 66.8 hm³/year, a reduction caused by the introduction of RWH in circular households and apartments. As the GREEN scenario emphasises RWH more than previous circular scenarios with a larger design, the reuse of rainwater is more efficient, with 6.3 hm³ being able to be captured and used to cover household demands annually. A more notable difference is the change in the urban runoff stream, with effects being introduced by the use of green roof spaces instead of the conventional impervious built surface. Firstly, a larger quantity of water is returned to the atmosphere, not only through interception and direct evaporation but also through plant transpiration from the green roofs. Moreover, the distribution of runoff between impervious and pervious surfaces changes, as green roofs are considered pervious and also direct their infiltration and overflow to pervious areas¹⁴. Finally, a notable difference is that sustaining green roofs also leads to higher water demands in dry seasons, with a demand deficit of 1.9 hm³/year on average that needs to be covered by other sources besides rainfall (i.e. the drinking water system). The horticulture system is the same as the WATWISE case, with most of the water being covered sustainably.

Finally, the WW2G scenario results at the coarse scale, seen in Figure 87, are comparable to the WATWISE scenario, with the notable difference that coverage of the greenhouse demands is now mainly achieved through reusing part of the wastewater effluent, equal to 5.0 hm³/year. This, in combination with the shallow basin system, practically negates any deficits and unsustainable groundwater abstractions to 0.07 hm³/year, with only one year out of the ten simulated ones indicating such abstractions. The rest of the displayed loops feature the same quantities as the WATWISE scenario in Figure 85, as the intervention options are the same (see Table 34). It is noted that, in the WW2G redesign scenario, the underlying assumption is that treated wastewater is directed through infiltration to the subsurface in a similar manner to the waterbanking system, even though there are other possible uses of the WW reuse technology for horticulture, such as direct transport to the basins of horticulture units (Krajenbrink et al., 2021).

More insights about the impact of different scenarios the domains of the water cycle can be obtained by looking at aggregated, (inter-)annual or monthly results. Starting at the household level, Figure 84 shows the efficiency in demand reduction at the tap level¹⁵ across different scenarios, as water-aware appliances become more prevalent in circular houses and apartments. The results are shown as average daily household consumption for the circular house and apartment type, but also scaled to an average household consumption for Delfland according to the percentages of circular houses seen in Table 34. Two of the scenarios (CCIRC and GREEN) have the same household consumption as BAU – and no further difference in circular household consumption – as demand reduction measures are not in place. For the other two scenarios (WATWISE and WW2G), the introduction of water-aware appliances can conserve 21.2%-21.7% of water (depending on the household type), or 4.3%-4.4% of the average household demand in the area for the assumed uptake rate (20% for households, 25% for apartments).

¹⁴ As per the scenario assumptions.

¹⁵ The tap level is equivalent to the point before the introduction of decentralized (RWH/GWR) or centralized water management options.

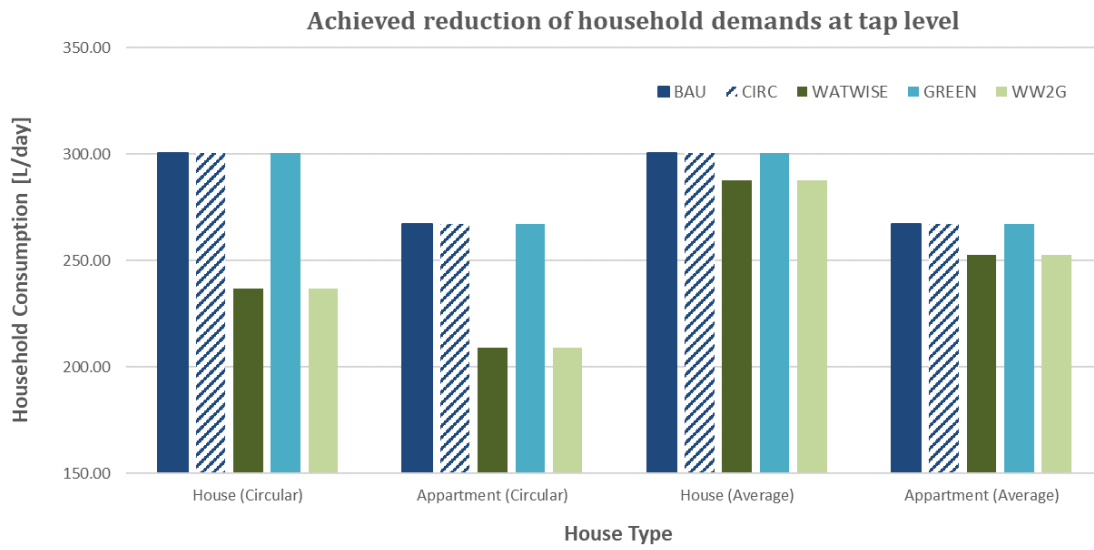

Figure 84 Model results in terms of household demands at the tap level.



Delfland Baseline

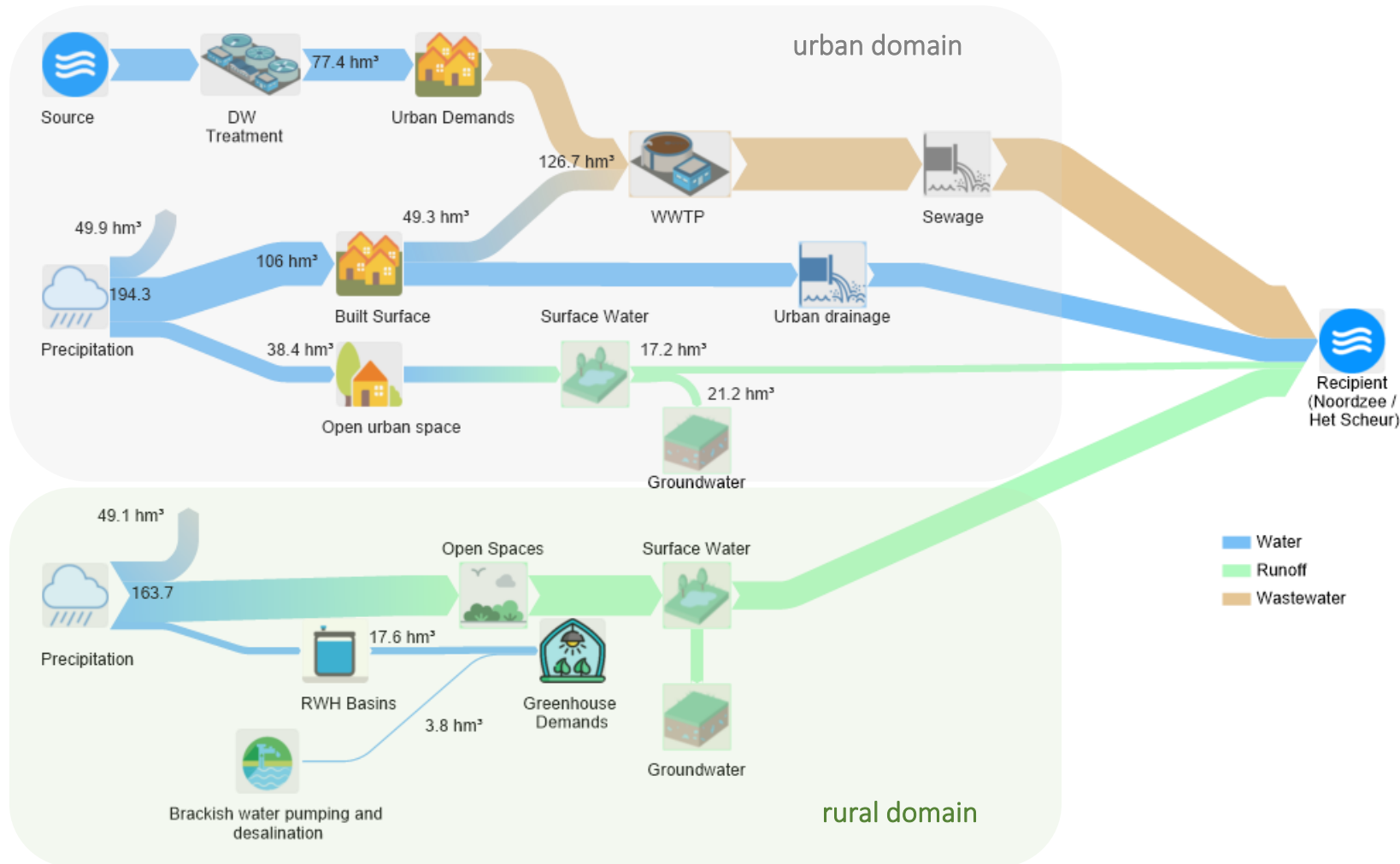

Figure 85 Sankey diagram of the UWOT baseline (BAU) case.



Delfland CIRC Scenario

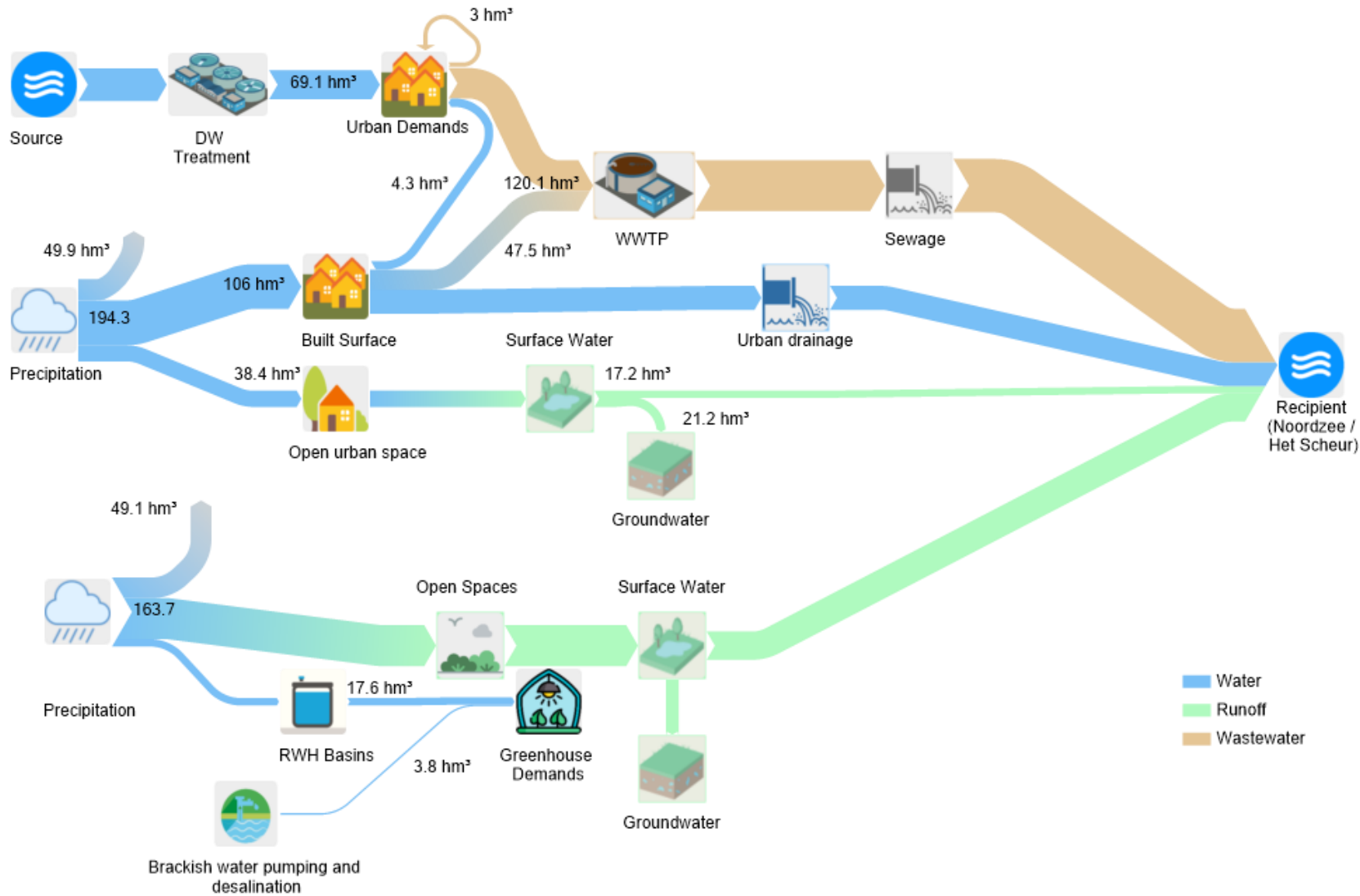

Figure 86 Sankey diagram of the UWOT CIRC redesign scenario.



This project has received funding from the European Union’s Horizon 2020 research and innovation programme under grant agreement N°776541

Delfland WATWISE Scenario

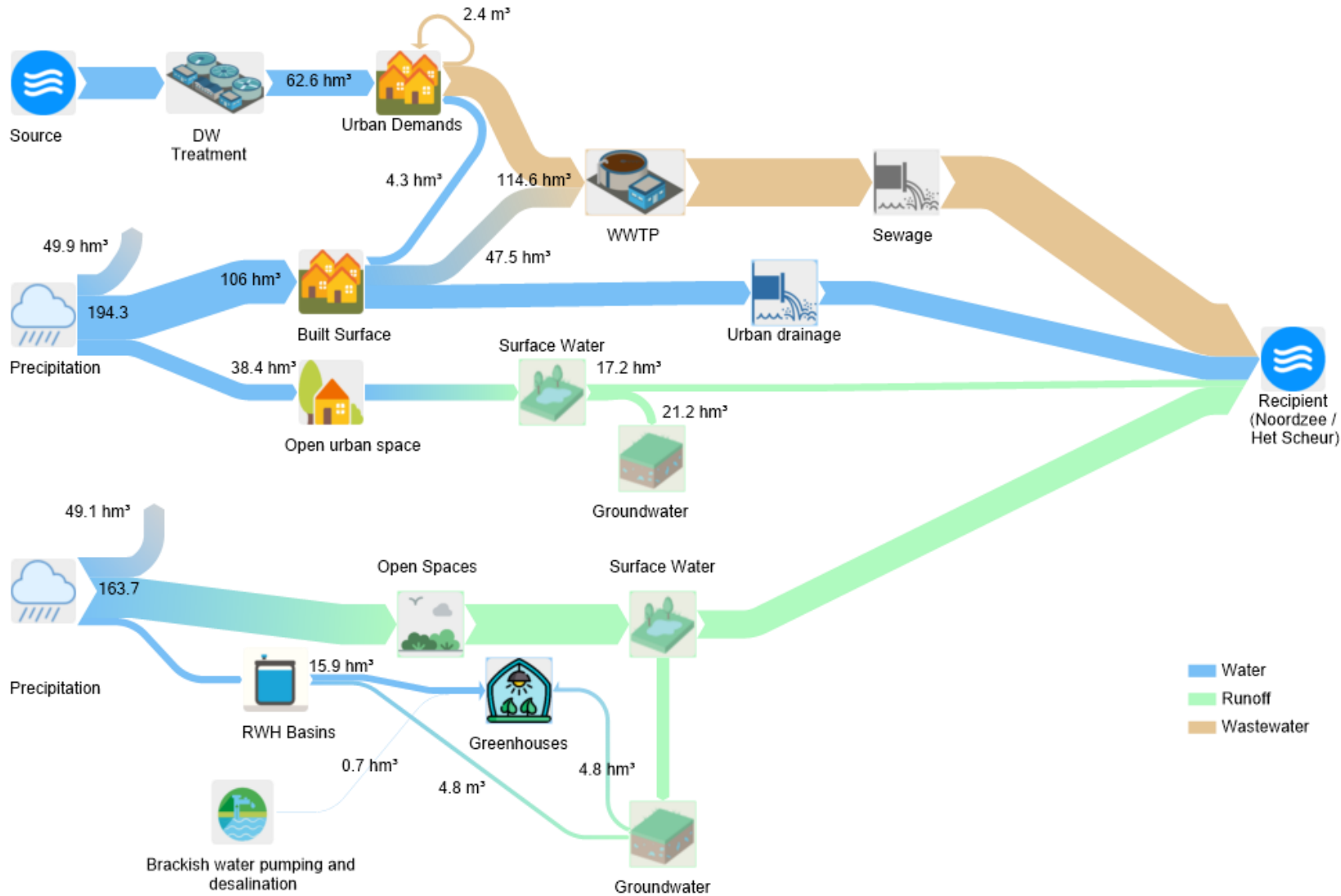

Figure 87 Sankey diagram of the UWOT WATWISE redesign scenario.



This project has received funding from the European Union's Horizon 2020 research and innovation programme under grant agreement N°776541

Delfland GREEN Scenario

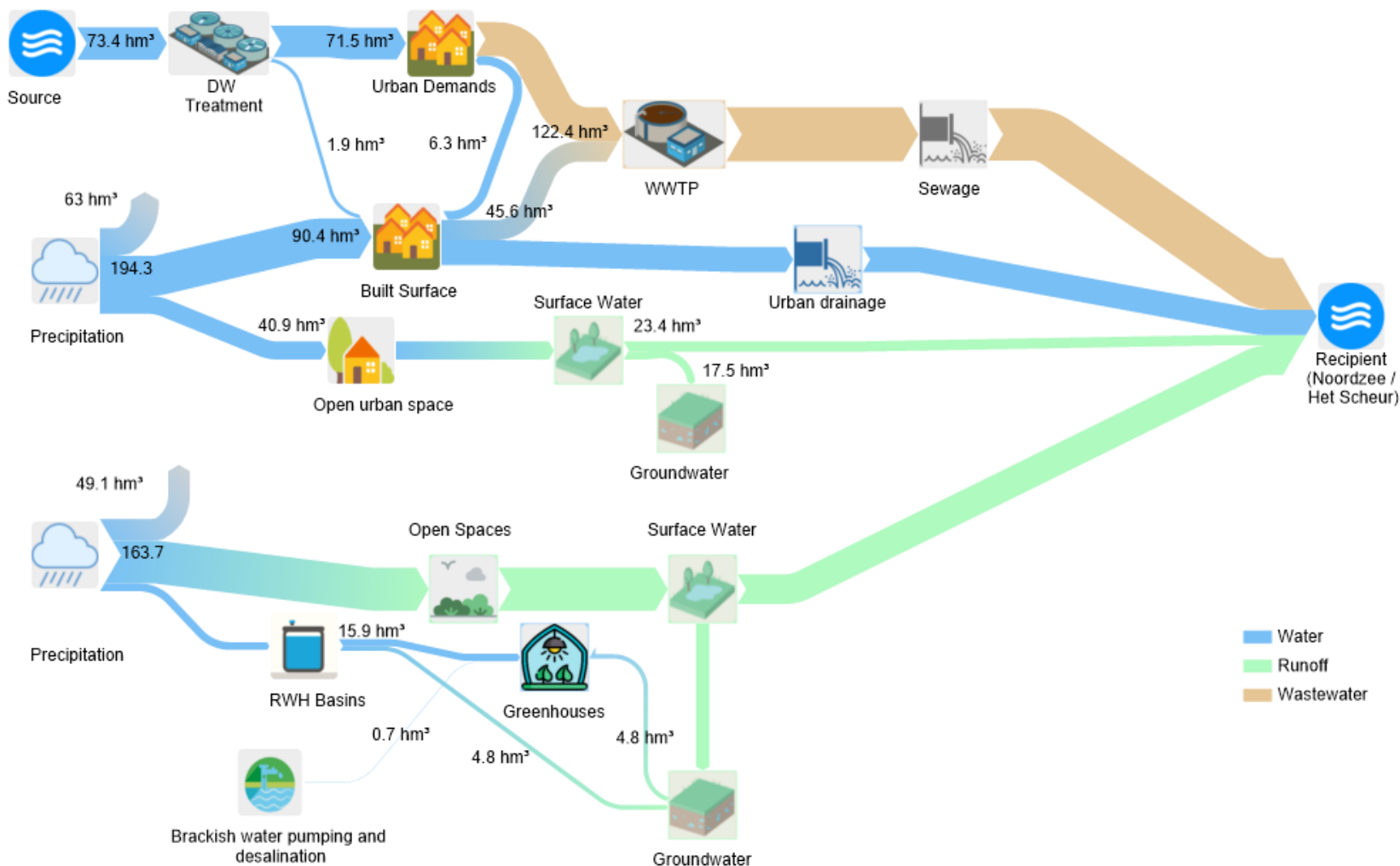

Figure 88 Sankey diagram of the UWOT GREEN redesign scenario.



This project has received funding from the European Union’s Horizon 2020 research and innovation programme under grant agreement N°776541

Delfland WW2G Scenario

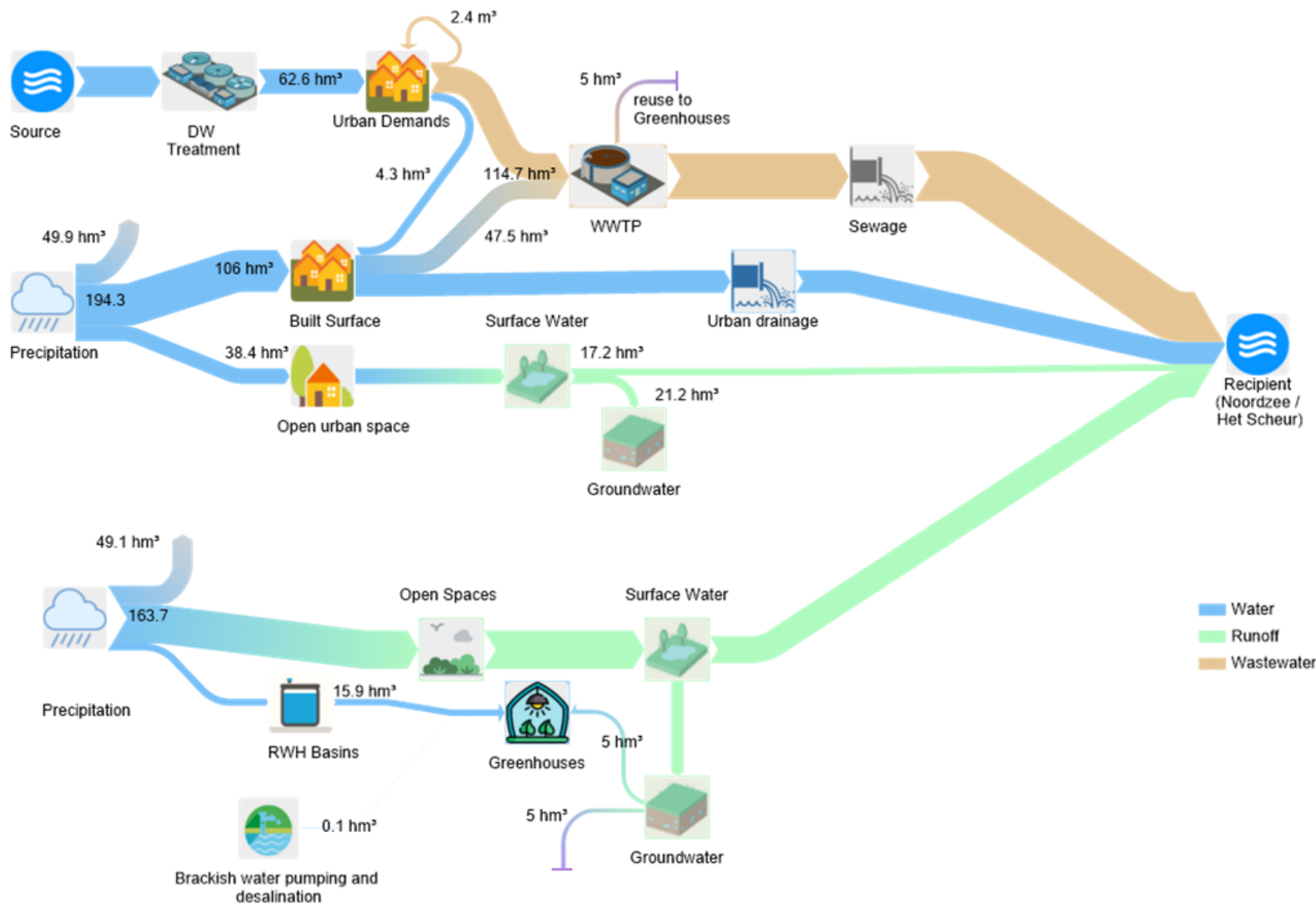

Figure 89 Sankey diagram of the UWOT WW2G redesign scenario.



This project has received funding from the European Union's Horizon 2020 research and innovation programme under grant agreement N°776541

Inter-annual and monthly comparisons in different aspects of the water cycle across redesigns can be insightful as well. For instance, Figure 90 displays the results across all simulated years in different urban water cycle domains such as urban demands that need to be covered centrally (panel (a)), urban runoff (panel (b)), and influx to WWTP, including and excluding the stormwater contribution (panels (c) and (d)). The results for scenarios WATWISE and WW2G coincide, as they feature differences only in the coverage of the horticulture domain. With regards to demands (panel (a)), every intervention is able to reduce dependence from the water utilities with varying efficiency (10.0%-11.0% for CIRC, 18.5%-19.4% for WATWISE and WW2G, 2.9%-7.0% for GREEN), with the WATWISE and WW2G scenarios having the highest reduction in central demands, as they combine decentralized and household-level measures. Interestingly, the GREEN scenario has less efficiency and introduces the highest variability in central dependence, as it focuses solely and more heavily on a source of uncertainty - rainwater (RW) - to cover demands, while the rest of the redesigns combine RWH with GWR. With regards to urban runoff (panel (b)), the situation is now reversed, as the GREEN redesign scenario is able to reduce runoff more efficiently (11.9% on average, against 5.5% using CIRC and 8.2% using WATWISE/WW2G). Panels (c) and (d) show the effect of the redesigns to the WWTP influx, and reveal the role of combined sewer systems; for instance, the GREEN scenario does not lead to a reduction in actual generated WW, but it does have an impact on the WWTP total influx as there is less urban runoff and more retained and infiltrated RW in urban zones. CIRC scenario features a notable reduction to generated WW, but this reduction is mitigated in the total WWTP influx, with results being similar to the GREEN redesign, due to the strong RW contribution that is not retained. Again, the WATWISE and WW2G redesigns show the highest efficiency in reducing effluent.

To complement annual results, Figure 91 shows the average monthly distribution of flows for the same domains, using the same panel lettering template. With regards to DW dependence from water utilities, panel (a) reveals that the GREEN scenario shows a seasonal variability on its efficiency as it emphasizes RW reuse; it has a similar reduction rate to CIRC in non-summer months but has a significantly reduced efficiency in drier summer months. The other redesigns that combine RW reuse with steadier reuse resources (such as GW recycling) show less seasonal dependency. Inversely, panel (b) reveals that the GREEN scenario has the most efficient reduction in the convective summer events, as the infiltration rate and transpiration rate¹⁶ from green roofs are higher. Panels (c) and (d) generally follow the same reduction rates as the annual ones, but reveal intra-annual variability which is introduced by both demand variability and the stormwater contribution from combined sewers.

¹⁶ Infiltration rate is dependent on antecedent soil moisture, while transpiration depends on temperature. Both of them are higher in the summer, dry months.

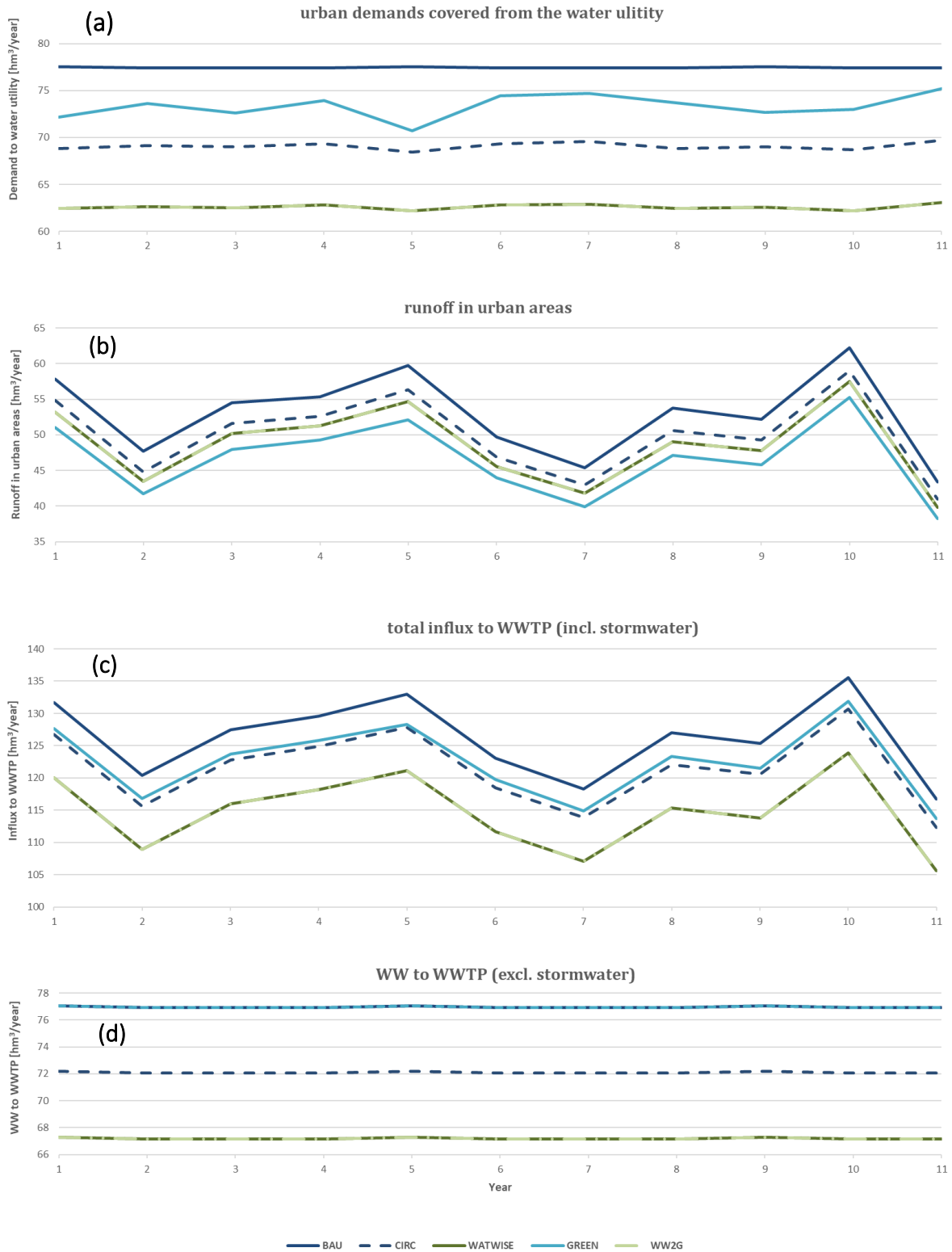

Figure 90 Results of redesign scenarios at the (inter-)annual scale.



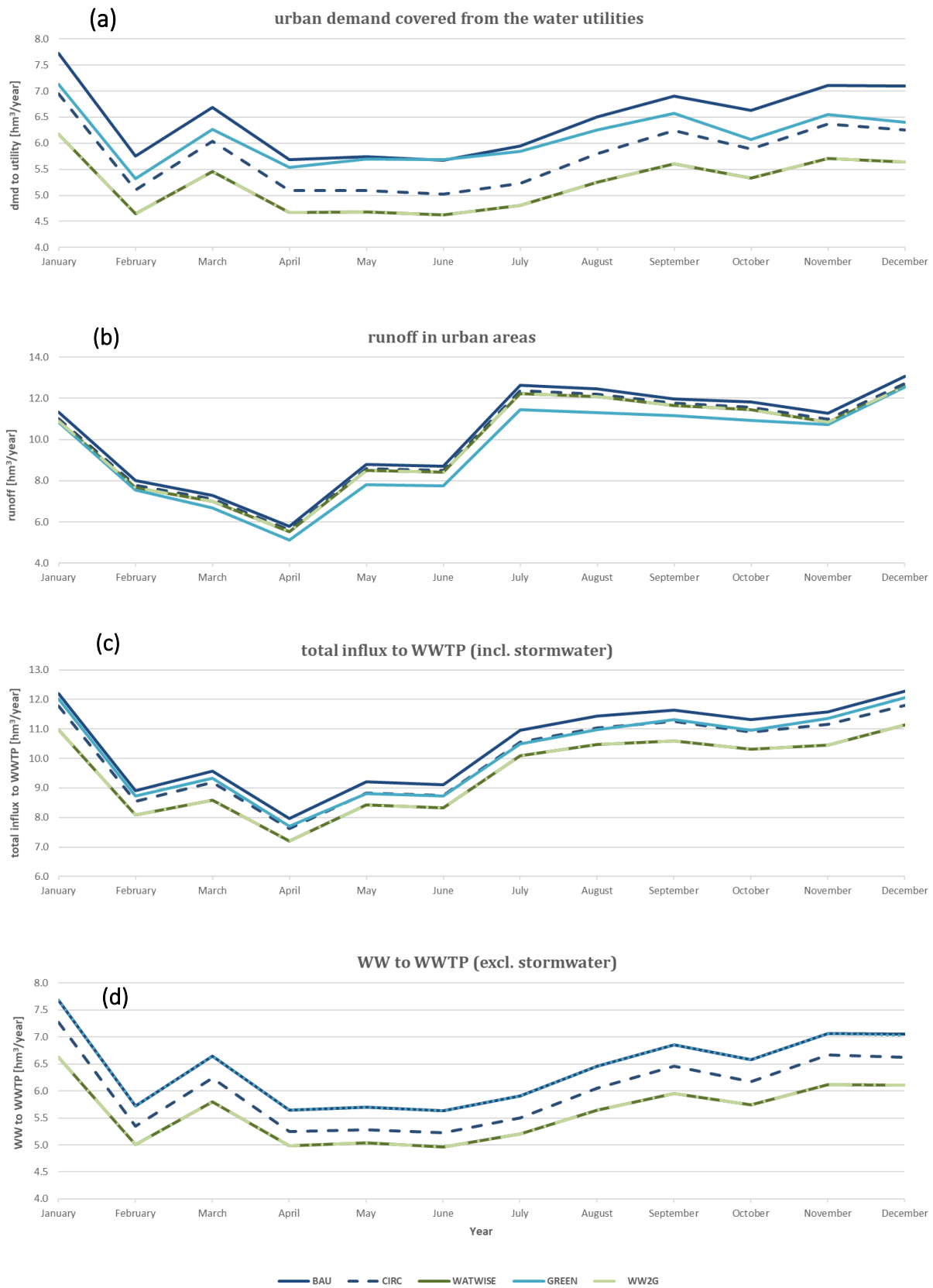

Figure 91 Results of redesign scenarios as average monthly flows.



6.3.4. Redesign results at the fine scale

Besides results at aggregate scales (annual or monthly), one may consult the simulation outcome at its native (daily) scale to observe how different sub-systems within Delfland perform, both in the conventional (BAU) as well as in the redesigned cases. This is particularly important for systems that depend on the fine-scale variability and intermittence of input (e.g. rainfall), such as the horticulture (greenhouse) system¹⁷. Figure 92 shows the fine-scale, simulation results of the horticulture system for the conventional scenarios that do not feature waterbanking or WW reuse (BAU, CIRC). The results are given at a unit scale (panels (a) to (c)) as well as at a system scale (panel (d)), in the form of time-series with a daily time steps, spanning across the entire simulation period. Panel (a) shows the seasonal variability of the greenhouse unit demands, with demand peaks in the summer months, paired with the unit roof runoff, which is an indication of rainfall water availability. One may see that, while for the largest part of the year roof runoff is larger than greenhouse demands, there are relatively dry periods with little runoff that coincide with high demands. This leads to the shallow basins of each GH unit (panel (b.)) being empty during part of the summer season, which in turn leads to system demand deficits (panel (d.)) which are covered externally (i.e. by pumping and using RO). The limited storage capacity of the shallow basins leads to frequent overflow in the wet months (see panel (c)), so the entirety of GH roof runoff is not able to be stored and used.

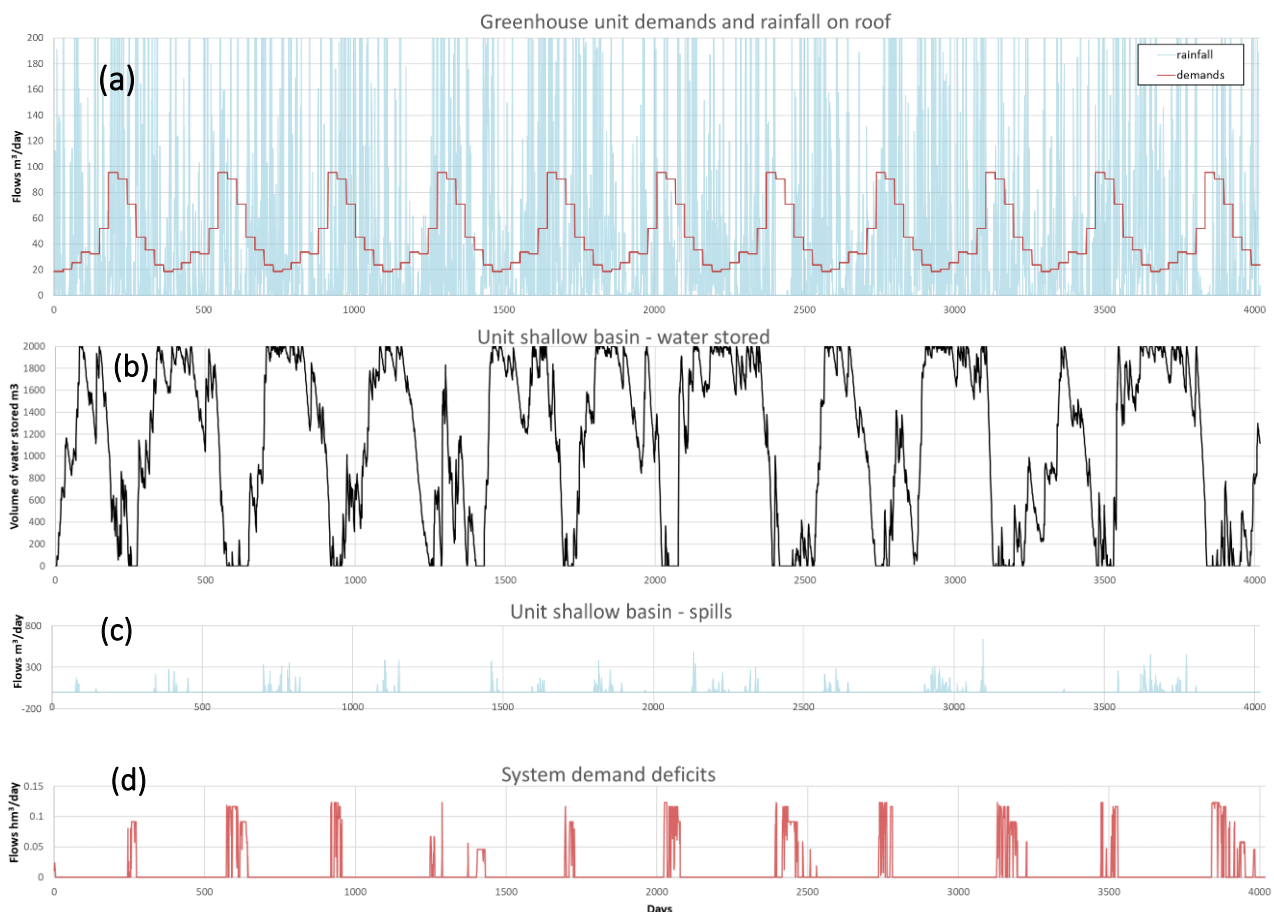

Figure 92 Fine-scale results of the response of the greenhouses in the conventional scenarios (i.e. without waterbanking).

¹⁷ Not all parts of the regional water cycle are exposed to daily variability in the current model – for instance, household demands are considered to occur at a constant, daily rate. They are still modeled at a daily scale, but viewing the results in form of time-series will not yield any extra information compared to the results at the coarse scale.



The situation concerning the GH system demand deficits changes substantially once more sustainable redesigns, such as waterbanking (WATWISE, GREEN) or WW reuse (WW2G) are considered. Figure 93 shows how the deficits change when infiltration is considered, either through the waterbanking system¹⁸ (so that rainfall is infiltrated in the subsurface), or through the WW2G scenario (where it is assumed that treated WW is directed to the subsurface). On the first case, variable runoff volumes are infiltrated to the ground (panel (a)), leading to a positive cumulative infiltration storage that covers the summer deficits to a very large extent (panel (b)). Some deficits are still observed in dry summers, leading to a small average deficit of 0.7 hm³/year, as presented before, but the system is more sustainable and doesn't rely on water imports every simulated summer. On the second case, where WW is reused, a smaller but much more steady stream of treated water is infiltrated in the subsurface (panel (a)), leading to a more robust cumulative infiltration storage that has a net benefit across the 10 years of simulation. The demands are largely covered, with only one simulated event of demand deficit (panel (d)), thus bringing the average annual deficit to 0.1 hm³/year. The cumulative infiltration storage also shows the infiltration and extraction rates of the GH system, that builds up stored water slowly in the subsurface but uses it, with a more rapid rate, when needed. Similar results can be also viewed for urban subsystems, such as the pervious and impervious urban areas or the water that is stored in the decentralized RWH and/or GWR systems in neighborhoods¹⁹.

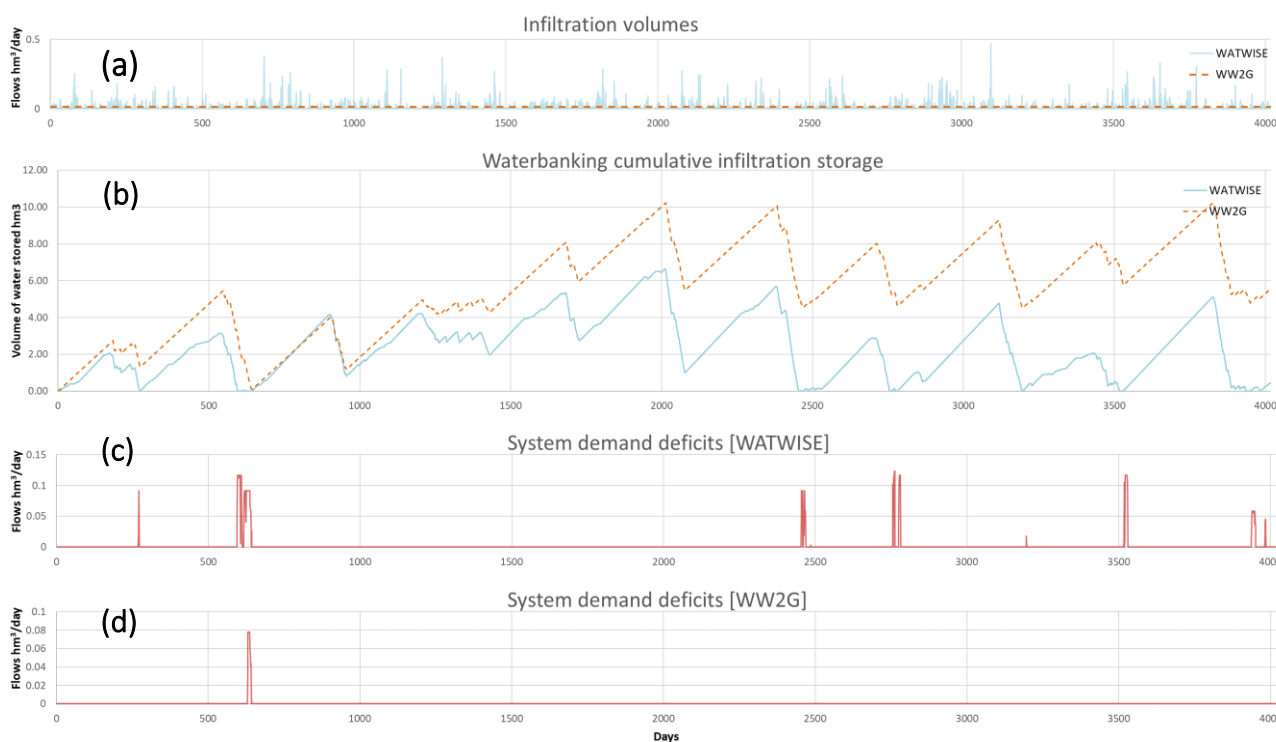

Figure 93 Fine-scale results of the response of the greenhouse system when circular redesigns are introduced.

¹⁸ The WATWISE and GREEN scenarios have similar waterbanking settings for horticulture, so they yield the same results for that subsystem. Only the WATWISE results are thus presented for simplicity.

¹⁹ The results are not shown at the body of the report to conserve space.



6.4. The stress testing

The process and results described on Section 6.3 assumes that the model of the current system - and the selected circular water redesigns – is forced and simulated with present-day conditions in terms of climate (rainfall and temperature), occupancy, urban and horticulture demands. A research question that follows is *how* both the conventional water system and circular water redesigns fare against the (uncertain) future. To tackle this, stress testing is employed, as a recurring simulation technique where the resilience of the system is evaluated against different possible futures (Makropoulos et al., 2018). Stress tests may use historical, hypothetical or simulated scenarios of possible futures or future extremes to assess how different system designs respond. In the case of Delfland, the following stress-testing scenarios are considered in separate:

- In terms of *climate*, the KNMI scenarios for the Dutch region (klimaatscenario's) that project rainfall and temperature changes are employed for 2050 and 2085 (Klein Tank et al., 2014). Each scenario provides a picture of changes in twelve climate variables, including temperature and precipitation, which are of interest to the UWOT model. In total, four scenarios are taken into account for each reference period (2050 and 2085), G_H , G_L (moderate temperature changes, high and low atmospheric pattern changes), and W_H , W_L (larger temperature increase, high and low atmospheric pattern changes).
- In terms of *occupancy*, an increase in the range of 0-40% compared to present-day occupancy is considered, with a granularity of 5% in each simulation run.
- In terms of *horticulture demand*, a uniform increase in the range of 0-40% compared to present-day horticulture demands for each unit is considered, with a granularity of 5% in each simulation run.

In order to assess system resilience, the formulation of relevant, suitable resilience metrics is needed. These metrics need to have practical value for regional decision-making, while accounting for modeling results and limitations (Bouziotas et al., 2019), so that they can be calculated based on model output. In literature, such metrics are also known as Key Performance Indicators (KPIs) (Moraitis et al., 2020) and are typically derived by statistically analyzing model output, which for UWOT comes in the form of daily timeseries for different urban water cycle streams (DW, WW and runoff, as well as water demand signals). Furthermore, to display system resilience, these metrics need to be closely linked to system reliability (Karim et al., 2021; Nikolopoulos et al., 2019, 2021). As part of the study in stress-testing, the following resilience KPIs are conceptualized, which include both:

1. event- (or time-) based reliability, which is defined in a simulation-based environment as the portion of time (%) that the system operated well. This is generally defined as $a_t = 1 - P_f = 1 - \frac{n_f}{n_{total}}$, where P_f is the probability of failure or inefficiency (Bouziotas et al., 2019), which is translated as the relative frequency of failed/inefficient time steps n_f against the total time steps of simulation n_{total} .
2. volumetric reliability, generally defined as $a_V = \frac{V_{supply}}{V_{demand}}$, where V_{supply} is the total volume of supplied water (e.g., from the utility or from local sources), while V_{demand} is the total demand of water asked from the urban or horticulture zone. Volumetric reliability can be readily considered as the percentage (%) of water that can be served from a (present-day) supply system, or – with regards to the horticulture system in Delfland – from sustainable sources such as the shallow basins or through water banking or reuse (Karim et al., 2021), with the latter being the case in the WATWISE, GREEN and WW2G redesigns.

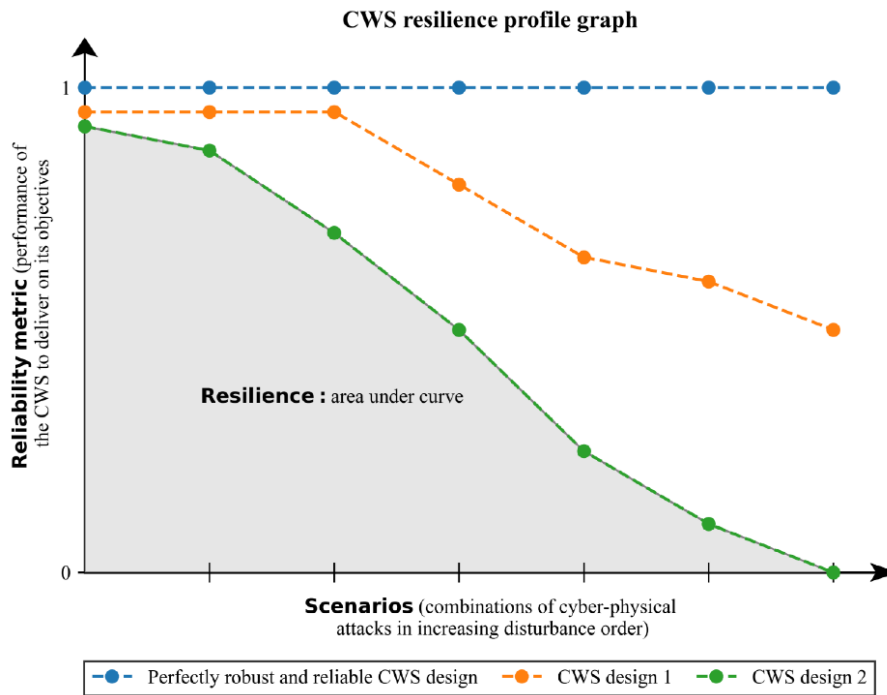

Figure 94 The concept of resilience in water systems (source: (Nikolopoulos et al., 2021))

Both metrics are defined to be equal to 1.0 for perfect simulated conditions (i.e., everything went well, no failure, inefficiency, or system deficits in terms of demands) and 0.0 for total failure/inefficiency in order to be consistent with resilience profile standards (Makropoulos et al., 2018). Moreover, to address the different water cycle streams and corresponding output modeled in UWOT, the following four (4) KPIs are derived, based on the two main categories of event-based and volumetric reliability defined above:

1. Reliability against Capacity Exceedance (RCE), an event-based metric defined as $a_{t,c} = 1 - P(Q > Q_c) = 1 - \frac{n_{Q>Q_c}}{n_{total}}$, where $Q > Q_c$ is the condition that a simulated quantity Q (e.g. the drinking water demand in a day) exceeds the system capacity Q_c . In the context of Delfland, it is assumed that the system capacity Q_c is the maximum value observed during the present-day (BAU) simulation, implying that the present-day system is tuned to run well across all simulation time steps²⁰.
2. Reliability against Demand Deficits (RDD), an event-based metric defined as $a_{t,d} = 1 - P(D_{def} > 0) = 1 - \frac{n_{D_{def}>0}}{n_{total}}$, where $D_{def} > 0$ is the exceedance condition for demand deficits at the external boundaries of the simulated system. This applies in the horticulture domain, to mark time steps where the horticulture system was not able to meet demands from internal sources (i.e. the shallow system basin, infiltration wells, or water reuse in the case of WW2G redesign).
3. Present-day Coverage (PC), a type of volumetric reliability defined as the % of demands able to be covered from the present-day supply capacity $V_{supply,pres}$, or in mathematical terms equal to the ratio $a_{V,c} = \frac{V_{supply,pres}}{V_{demand}}$.

²⁰ In general, the daily system capacity Q_c can be set to a specific value to reflect good operating conditions, e.g. operational conditions without any loss of pressure or customer minutes for a supply network. In this study of Delfland, it is derived from the present-state simulation of the system, with the reasonable assumption that the present-day supply network is fine-tuned to run well in present-day conditions.



4. Sustainable Coverage (SC), a type of volumetric reliability defined as the % of demands able to be covered sustainably $a_{V,c} = \frac{V_{supply,sust}}{V_{demand}} = 1 - \frac{\sum_{t=1}^n D_{def}}{V_{demand}}$, i.e. by internal reduce-reuse-recycle loops. This metric applies to the horticulture system²¹, where the aim is to cover demands sustainably as much as possible and is calculated by calculating the cumulative deficits and dividing them by the total demand volumes, in order to measure the volumetric exceedance rate at each stress-test scenario.

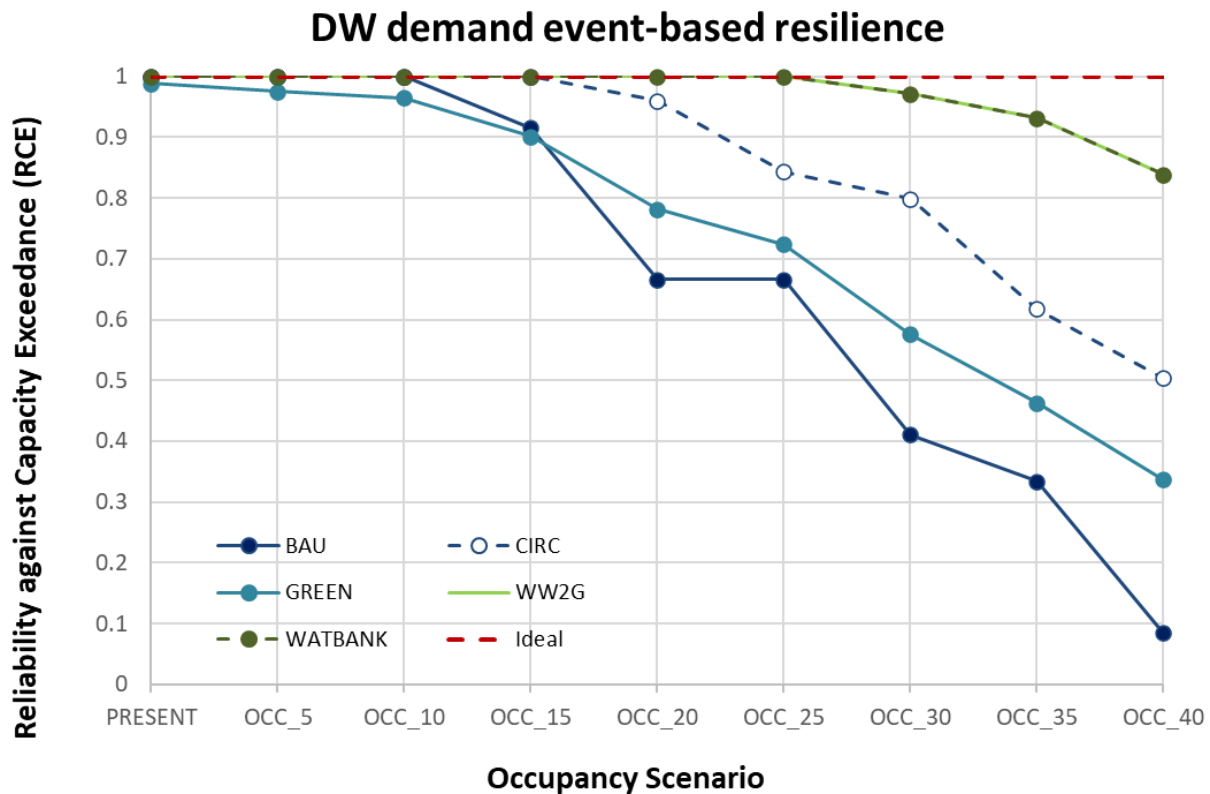

Figure 95 Resilience against increasing DW demands using the RCE metric.

The results in terms of Drinking Water (DW) reliability can be seen in Figure 95 for Reliability against Capacity Exceedance (RCE, event-based reliability) while Figure 96 shows Present-day Coverage (PC, volumetric reliability). The forcing of interest, in this case, is an increase in occupancy, which in turn leads to elevated urban demands. In both cases, leaving the system as-is (BAU case) will result in the less resilient option, which for instance means that a system with 25% higher occupancy will have 87% reliability in terms of volume, which will be delivered safely only 66% of the time. The GREEN redesign also loses reliability against a progressive increase in occupancy, as it leads to higher demands due to maintaining green roofs, but it still remains a more resilient option than the choice of inaction. The options with the highest resilience are WATWISE and WW2G redesigns, which lead to ideal system performance in terms of delivering water demands for up to a 25% occupancy increase and lead to high reliabilities (RCE of 83% and PC of 93%) for even a significant occupancy increase by 40%.

²¹ While it makes sense to apply the metric in urban contexts as well, such as decentralized neighborhoods (Bouziotas et al. 2019), it cannot be applied in the DW supply network of Delfland that relies in external riverine water quantities.



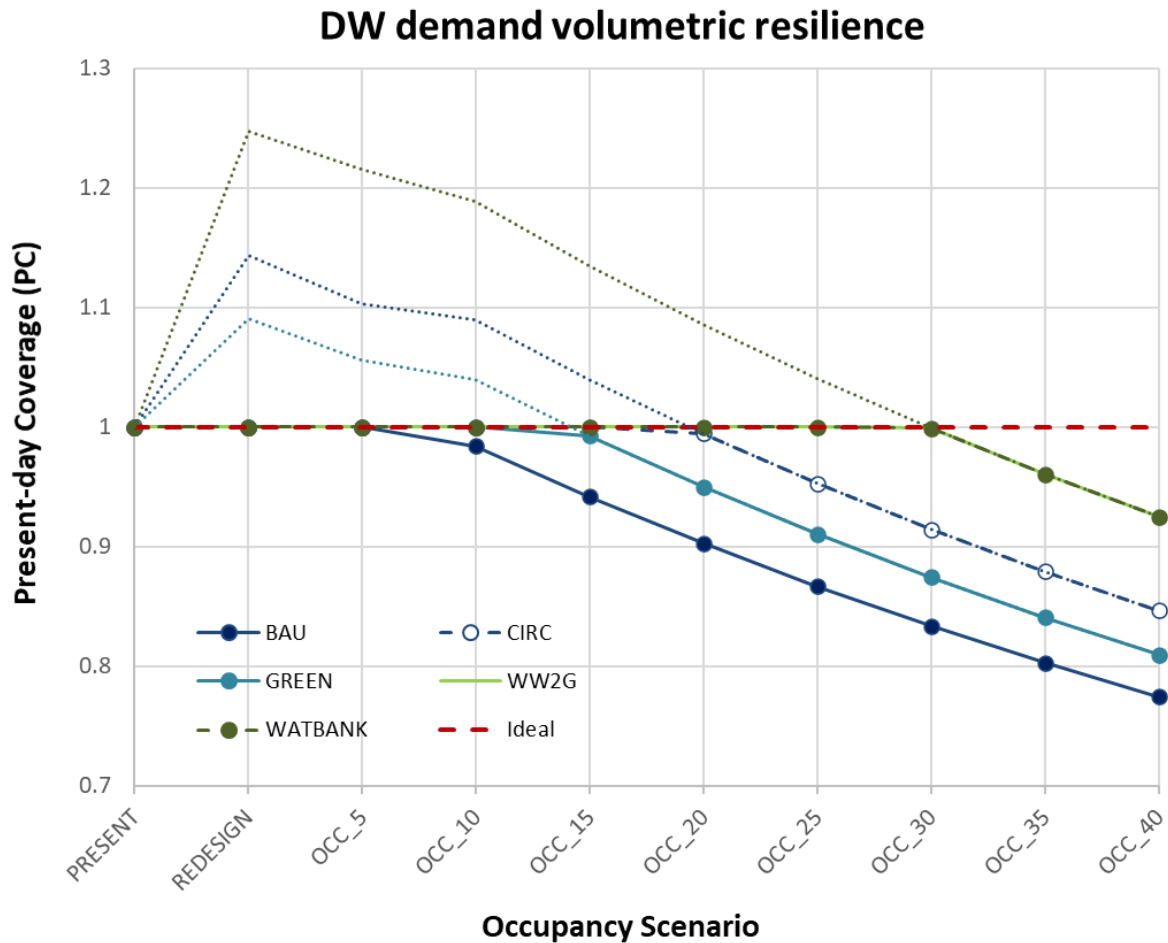

Figure 96 Resilience against increasing DW demands using the PC metric.

An interesting finding in Figure 96 is that, by definition of the PC and SC metrics²², any demand reduction measures will lead to $V_{demand} < V_{supply,pres}$ for present conditions, so the ratio can be larger than 1.0. This means that any redesign that leads to demand reduction (through water-aware appliances or decentralized measures, such as RWH and GWR), without further alterations to the capacity of the supply system, builds up resilience for the system that can be used if external conditions (such as occupancy) become more adverse. This is visualized in Figure 96 with the dotted line, showing this buffer for each redesign in the REDESIGN point of the horizontal axis. This increase cannot be seen from an operational perspective, so the actual resilience never grows to larger than 1.0 (as seen in Figure 96 with the continuous lines), as the (lower) demands asked by the redesigns are still always delivered by the supply system. However, it leads to system designs that retain high reliability for more adverse conditions. The redesigns that lead to the higher resilience are, again, the WATBANK and WW2G options, followed by the CIRC and GREEN options. Volumetric resilience findings tend to agree, overall, with event-based resilience, with the less resilient option being the present-day, centralized system as-is.

²² In principle, similar behavior can be theoretically seen in the SC results of Figure 97, but the system redesigns do not provide this extra capacity, as they are designed with the assumption that they completely negate present-day deficits (instead of securing against increased deficits in the future), thus bringing volumetric reliability to 1.0.



Besides DW demands, scenarios of increased occupancy will also lead to higher WW volumes in the WWTP. Figure 97 shows the relevant resilience of the different system redesigns against an increase in the WW volume that results from higher occupancy. WW2G and WATBANK continue to show consistently good behavior, while the GREEN and BAU show similar results in terms of resilience; this is reasonable as the GREEN is the only scenario that focuses on RWH and does not include WW reuse (e.g., through GWR), as a measure for the circular households.

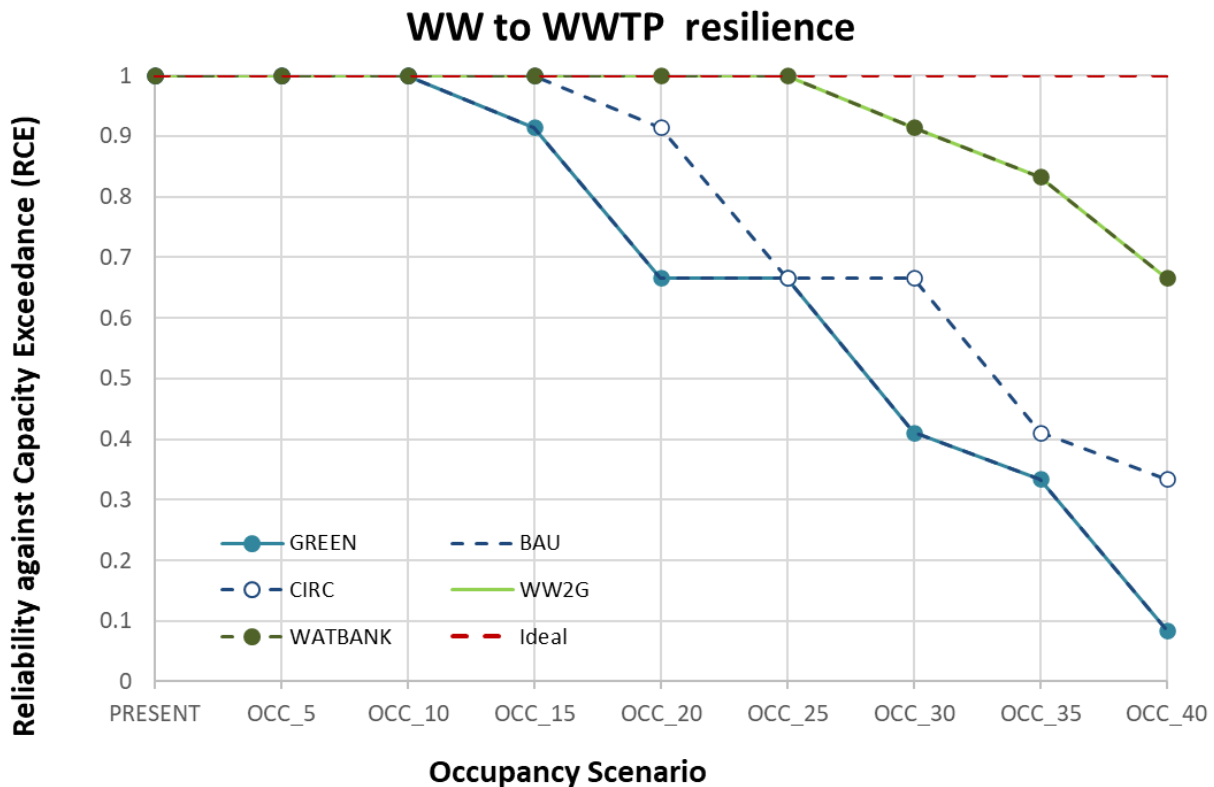

Figure 97 Resilience of the WW influx to WWTP using the RCE metric.

For the greenhouse (GH) system, the metrics of RDD and SC are used to cover event-based and volumetric resilience correspondingly. The results, shown in Figure 98 and Figure 99, show that the present-day management relying on shallow basins fails 12% of the time and is only 82.7% reliable in terms of the volume of covered demands. This unsustainability is reversed by the water banking solution (GREEN and WATWISE redesigns), which lead to a high event-based reliability of 97% and sustainable coverage of 96.7% for present-day conditions. The WW2G option shows even more reliable results, leading to an event-based reliability of 99.7% for the 10 years of simulation. Both of these solutions also secure the system against potential increased horticulture demands, as they retain reliability levels larger than 90% for the scenarios where horticulture demands increase by 15-20%. An interesting finding is that the reliability loss (i.e. resilience curve slope) of waterbanking when conditions become more adverse is slightly higher than the WW2G redesign; this is reasonable as waterbanking relies on an intermittent source, while WW2G provides a steady source of water to the system. This can be noticed as the distance between the two curves in Figure 98 and Figure 99, which progressively grows larger as the horticulture demands become increased. Again, the two-resilience metrics show good agreement with regards to how resilient each redesign is.



Horticulture demand event-based resilience

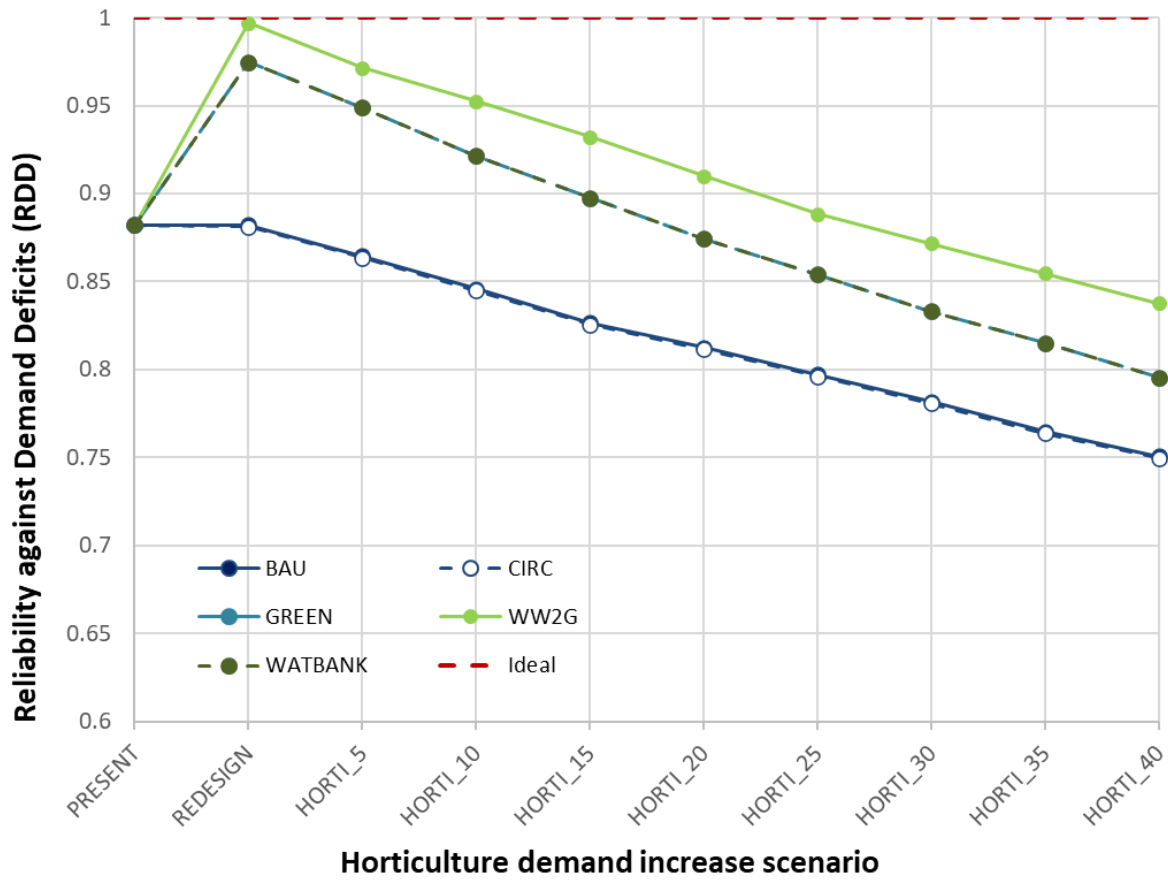

Figure 98 Resilience against increasing horticulture demands using the RDD metric.



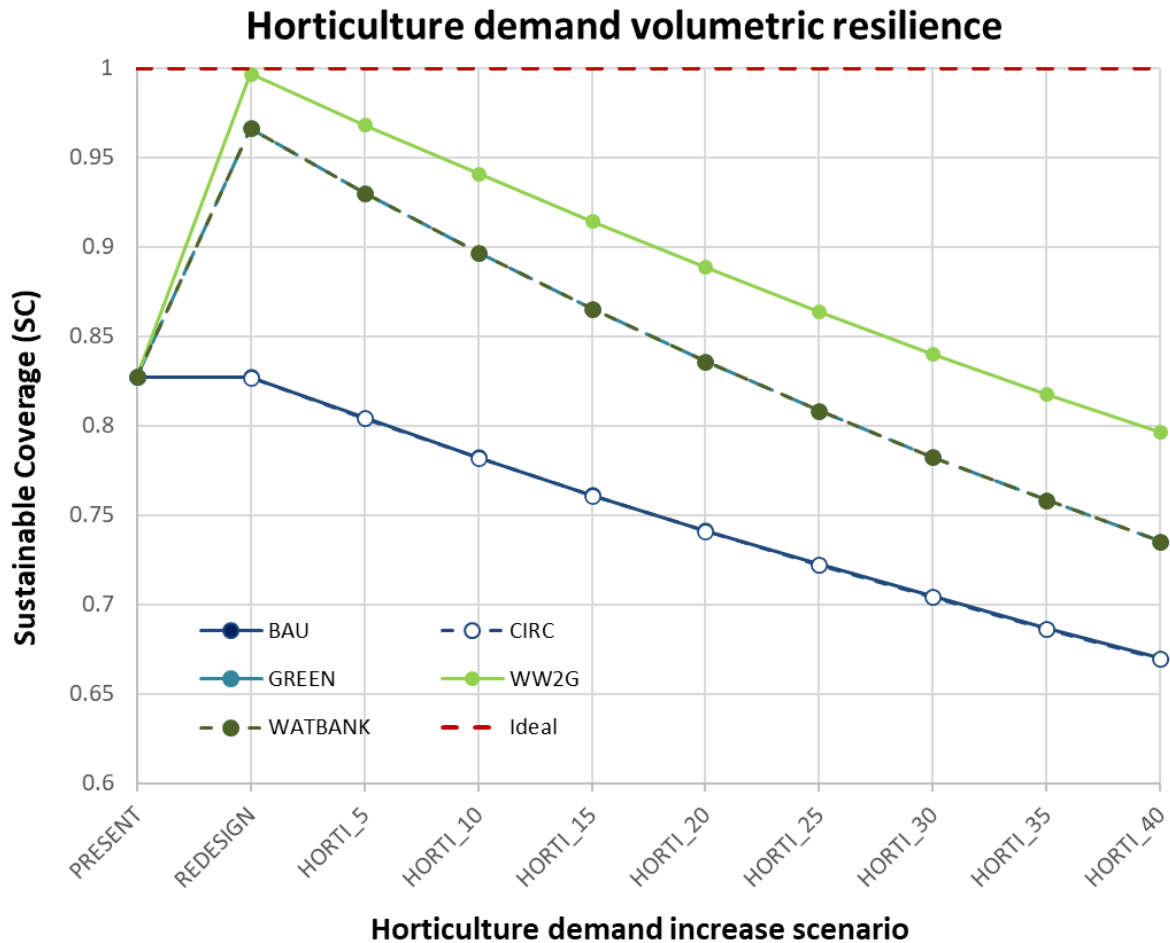

Figure 99 Resilience against increasing horticulture demands using the SC metric.

Finally, the system resilience against possible future climates can be seen in Figure 100 and Figure 101, based on the KNMI climate projections, with each point being a different projection scenario (G_H , G_L , W_H , W_L). Again, the highest consistency in both event-based and volumetric resilience is shown for the WW2G redesign, followed closely by the WATWISE and GREEN redesigns (whose results coincide, as they feature the same design of the horticulture system using waterbanking). The CIRC and BAU designs also coincide, as CIRC doesn't feature any changes in horticulture, and have a markedly lower reliability that falls to 86% (RDD) and 78% (SC) on average in 2085. The largest spread across different climate scenarios can be seen for the WW2G option, while the WATWISE and GREEN options show higher consistency across different emission futures. Despite the higher spread, the WW2G remains the most reliable option both for 2050 and 2085, but gradually converges towards the reliability seen in the waterbanking system. No design features a significant loss of reliability, which might be an artifact of the climate product used, as the rainfall volumes of the KNMI scenarios do not change significantly in 2050 and 2085; however, the largest drop of reliability is seen for volumetric resilience (Figure 101), indicating that, while timing patterns are not dramatically different, the magnitude of extremes and the resulting annual volumes of precipitation change to a drier setting.



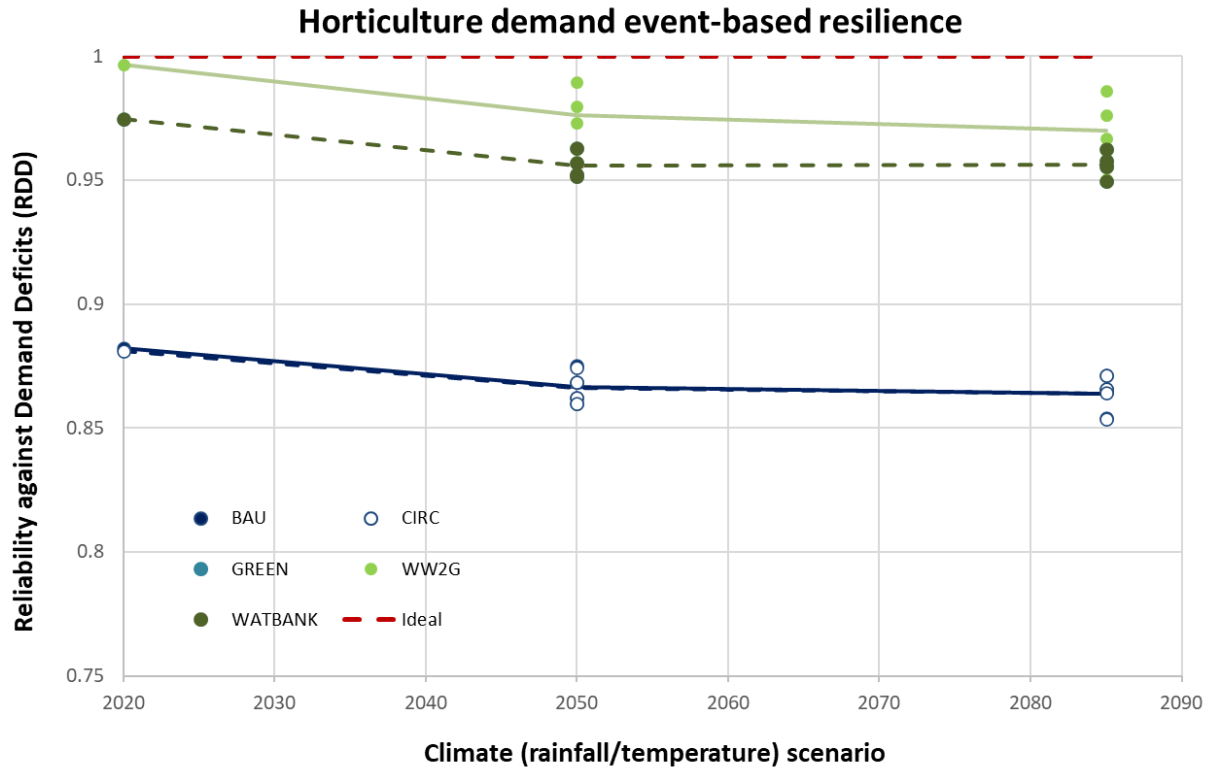

Figure 100 Resilience against possible future climates using the RDD metric.

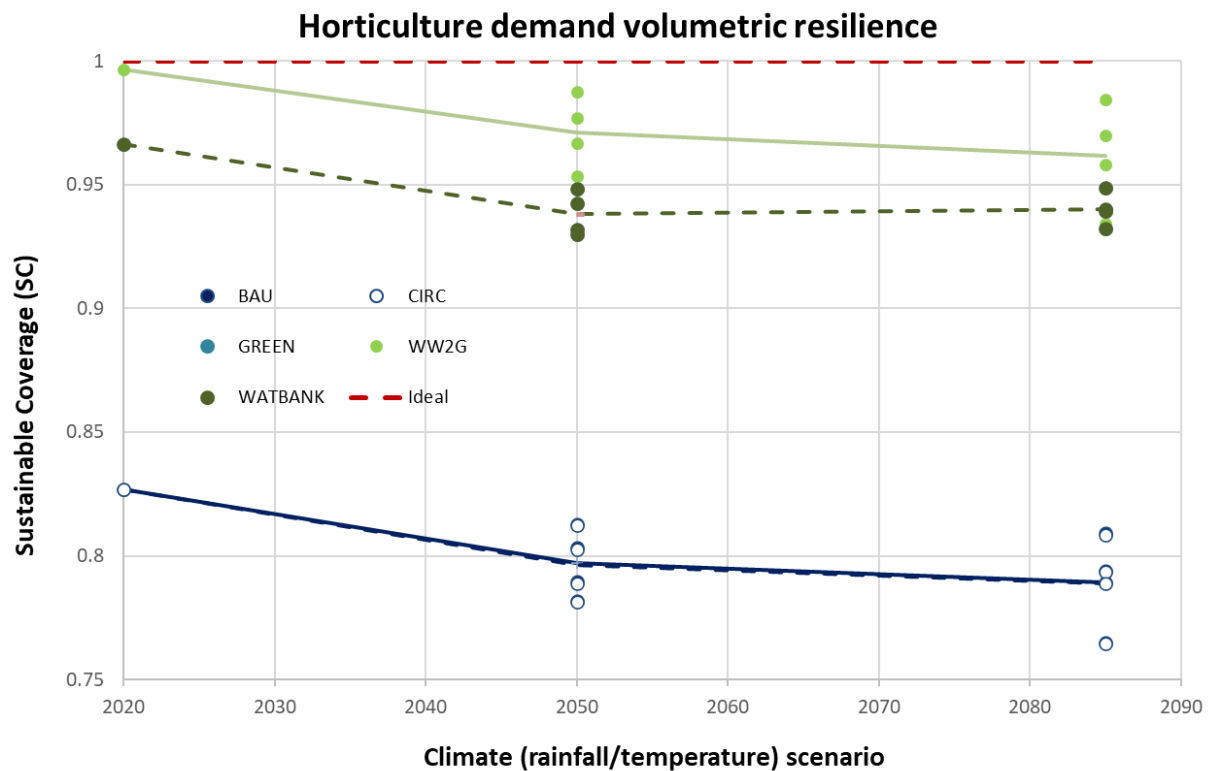

Figure 101 Resilience against possible future climates using the SC metric.

7. The Filton airfield demo case (UWOT)

7.1. Case description

The Brabazon Development is a mixed-use development located at the Filton Airfield site, just outside the city of Bristol. The intention is to integrate a sustainable residential neighbourhood with education and commercial opportunities while promoting the historical significance of the Filton airfield (YTL Developments, 2019). The construction of the development is expected to last for over 10 years, leading to the final phase of homes and office spaces after 2030. However, the first phase of the development, which includes 278 housing units, is currently (as of September 2020) under construction with a scheduled opening in late 2021.

UWOT has been used to simulate water scenarios for the first phase of the development with the intention that the results and findings from the research providing a useful business case for YTL Developments in the future phases of the development. Figure 102 is the plan proposal for the first phase of the Brabazon Development which represents the case study for this research. The diagram highlights that the phase includes 1 and 2 bedroom apartments and 2-, 3-, 4- and 5-bedroom housing units (YTL Developments, 2019).



Figure 102 Phase 1 Residential area

The study conducted was focusing on the feasibility of a rainwater harvesting system and its performance. First the urban water cycle was simulated with UWOT. Water balance scenarios were

developed that were used to assess the economic feasibility and socio-environmental benefits of rainwater harvesting. Rainwater was treated, stored and then distributed for non-potable residential use. Excess of rainwater is spilled via a stormwater network. A simplified schematic of the water balance model is shown in Figure 103 and the full model in Figure 104.

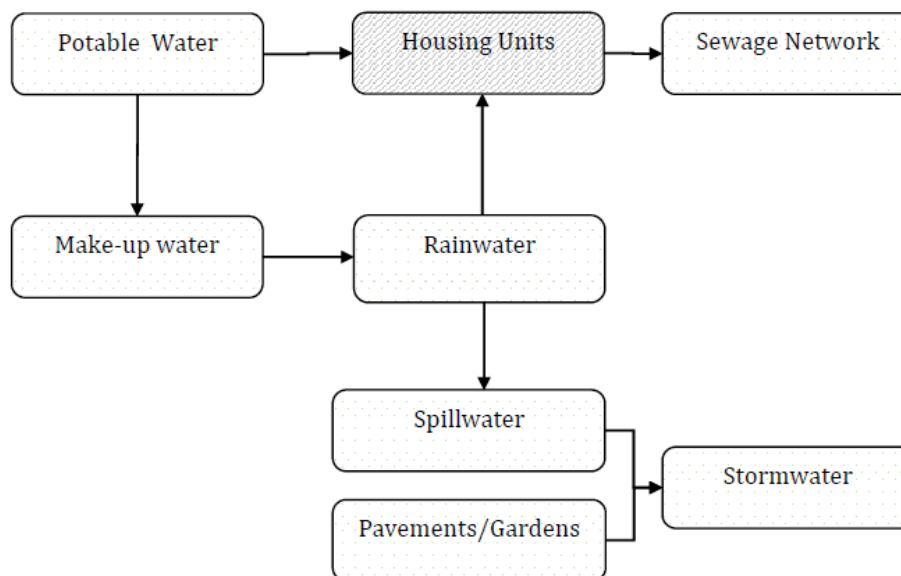

Figure 103. Simplified urban water cycle model.

Rainfall data are based on data from a weather station near the site, operated by the University of Bath, and a few weather stations in the area. Quality checks have been done by Pearson’s correlation checks between the data sets from the different stations. This delivered an accurate rainfall data set for a period between September 2010 and October 2020. Based on the housing plan shown in Figure 102, a total surface area for rainwater collection was estimated at 16,700 m² (total roof surface). Some of the collected rainwater is expected to evaporate again. Two scenarios were calculated: 70% and 90% runoff (30% and 10% evaporation).

For the demand side characteristics, a distinction was made between potable and non-potable uses. To estimate water use, first the occupancy of the different types of houses and apartments had to be determined. Minimum and maximum occupancy were calculated, based on the number of bedrooms in each house. Water consumption per use and appliance were used from pre-set values in UWOT. These were compared to BREEAM Domestic Use Parameters. The UWOT values were compared to the BREEAM Level 3 rating.

Storage and treatment are important aspects of a rainwater harvesting system too. Storage capacity should be appropriate to create sufficient storage that covers most of the demand and prevents spilling. Tank materials should not adversely affect the water quality. For treatment filtration steps are often required to remove suspended solids. It was assumed in this study that the system was equipped with a first-flush system, that removes the first water that is collected after an antecedent dry period.

Two scenarios have been assessed: the best case combines the highest rainwater supply with the lowest water demand, the worst case represents the opposite, i.e. the highest water demand combined with the lowest rainwater supply.



7.2. Results

The results from the simulation are presented as best- and worst-case scenarios. For each scenario, the simulation calculates the potable and non-potable water demand, the total collectable rainwater, the make-up water for topping up the rainwater tanks in dry periods, the spilled rainwater (tank overflow), garden and pavement runoff and the total stormwater volume. Also, the number of failures – when non-potable demand is covered by supplying drinking water – needs to be determined. The number of failures is an important measure to optimize the storage tank size. The results are shown in Table 35 to Table 37.

Table 35 Best case scenario results.

House type	Potable demand (m ³ /year)	Non-potable demand (m ³ /year)	Total collectable rainwater (m ³ /year)
Apartments	7008	2856	1888
2 Bedroom	2473	1008	2947
3 Bedroom	3710	1512	3844
4 Bedroom	4809	1960	2292
5 Bedroom	6011	2450	2740
Totals	24012	9787	13712

Table 36 Worst case scenario results.

House type	Potable demand (m ³ /year)	Non-potable demand (m ³ /year)	Total collectable rainwater (m ³ /year)
Apartments	35720	21641	1073
2 Bedroom	4728	2864	1694
3 Bedroom	6304	3819	2192
4 Bedroom	7661	4641	1318
5 Bedroom	10725	6498	1550
Totals	65138	39463	7828

Table 37 Additional results from the simulations.

	Make-up water (m ³ /year)	Spillwater (m ³ /year)	Runoff (m ³ /year)	Stormwater (m ³ /year)	Failures
Best case	1106	5000	3433	8433	512
Worst case	31645	9.4	3433	3442	3569

The data show that in the best-case scenario sufficient rainwater can be supplied to cover the non-potable demand. More detailed analysis on day-to-day performance however shows that even in the best-case scenario, failures and spills will occur. The analysis shows that in 89% of the non-



potable demand can be covered in this scenario. Further optimization of the storage size could improve the scenario.

The worst-case scenario shows a dramatic increase in water demand. In this case the supply of non-potable demand by rainwater is not feasible.

Further detailed information on the study will be available in D1.8.

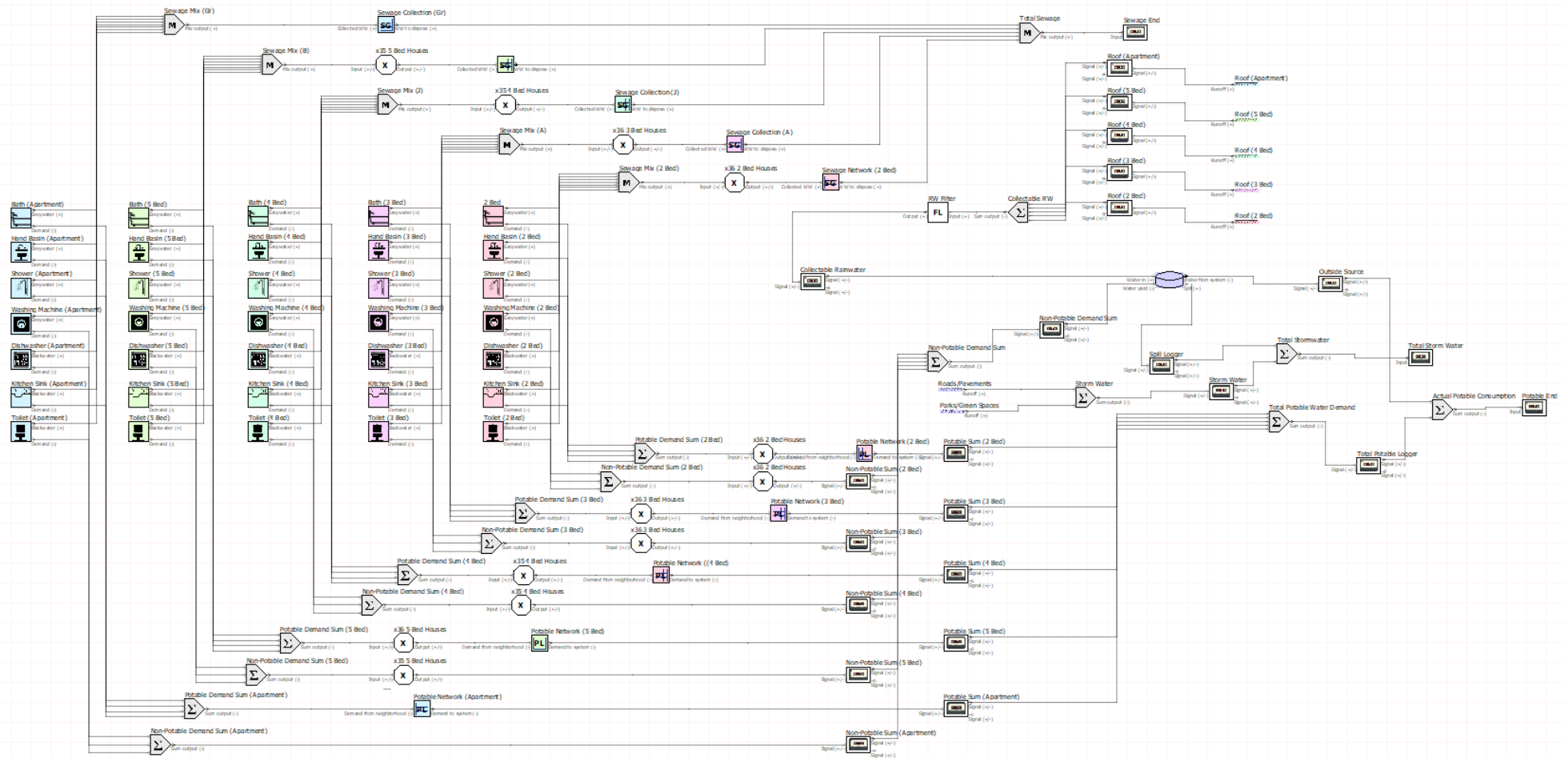

Figure 104 Urban Water Optioneering Tool Simulation Model.



This project has received funding from the European Union’s Horizon 2020 research and innovation programme under grant agreement N°776541

8. Conclusions

8.1. Hydroptim

8.1.1. Conclusions

NextGen tools HydrOptim has been updated, and the re-design and stress test of NextGen selected case study systems executed, obtaining results for Costa Brava and Delfland demo cases. The Hydroptim Software has shown its capabilities to modelize and optimize the cost of the water networks, and its uses in short and long term planification. Also, its application in evaluation of different cost of “what-if” studies as in the Delfland demo case,

Although it is included, in the project it was not necessary to perform the real-time optimization of the operational model, an only short term and long-term optimization for planification was used, and the different studies of “what-if” scenarios.

For Costa Brava demo case, after some initial demonstration of the tool, the end user has decided to evaluate the different scenarios defined for scarcity that affects the availability of the water resources. The cost increase of needs for any water source has been studied and compared, using a normalized price of energy.

- The scarcity scenarios, where the current main source of water is reduced have been studied.
- The stress test scenarios, where more restriction from the aquifer are applied, have been also evaluated, with the increase of cost associated to the use of water from the desalination plant.

For Delfland demo cases, in all scenarios the Hydroptim tool makes no optimization as the model is determined by the demands and a single source of water for each of the branches. Also, in both cases, the results are consistent with the estimated costs and correspond to the expected outcomes.

- In Scenario 1, the demand of the cities is satisfied with desalinated water from the sea, while for the irrigation needs, reclaimed water from the urban areas as well as rainwater.
- In Scenario 3 it has been observed that used rainwater can meet the entire demand of the cities. It has been calculated that the water management eliminates the need for desalinated water, resulting in significant energy and cost savings.

The main limitation observed in the tools is that in some scenarios, where there is a loop in the path of the water, extra elements have been added to ensure the mathematical solve of the optimization problem.



8.1.2. Lessons learned

The Hydroptim tool was selected in this project to evaluate different scenarios of hydraulic networks thanks to its capability of optimising cost of the system. Although initially cost came only from energy costs (that currently is probably the most important part in OPEX of networks), the adding of the environmental cost allows to evaluate also different alternatives of sources of water.

In the project the results of the tool were used to compare different scenarios in terms of cost, but the absolute value of the cost was not used.

8.1.3. Future Plans

For Hydroptim Software there are two tasks planned after the end of the project:

- The first one is to define, using the work done in “D5.1 New business models and services related to CE” the business model to commercialize the Hydroptim tool. This task includes the definition of the markets, possible users and services to
- Evaluate the inclusion of the water quality as a characteristic of the different source of water and as a restriction in the water consumers

8.2. UWOT

8.2.1. Conclusions

Some conclusions specific to the case of Delfland are that:

- UWOT is able to provide a holistic view on both urban and horticulture domains of the regional system, treating it as a unified urban-regional water system (URWS), where different redesigns that target either (or both) subsystems can be quantitatively compared and stress-tested against uncertain possible futures.
- Among the compared redesigns, the more ambitious redesign strategies that include sustainable options for horticulture and combine demand reduction measures with decentralized RWH and GWR for the urban area were found to be the most efficient in reducing demands, reusing and recycling water locally and securing the system against future uncertainty. Among them, WW2G was found to increase reliability the most in the water cycle, followed by the WATWISE and GREEN options. Even simpler strategies that target one domain (such as CIRC) are significantly beneficial to the region and lead to a more resilient future. In any case, the cost of inaction for Delfland will be high, as the conventional, linear water management system will not be able to secure urban and horticulture demands reliably without significant investment in increasing central supply.

Some limitations that were observed vis-à-vis other models for Delfland are that:

- While the model is calibrated using all available regional and water system data, there are slight deviations from sectoral models, for instance in the horticulture domain where sector-specific horticulture water banking models were found to have total reliability for the proposed waterbanking redesigns (100% reliability, vs. 97% reliability for UWOT). This deviation is caused by the operational rules of the shallow basin



- system (start of infiltration and overflow from the shallow basin), which cannot be modelled in detail and are thus more conservative in the case of UWOT.
- This means that UWOT is able to provide an accurate system view and compare different systems at a preliminary stage, but has to be used as a complement to sectoral hydrological models in case detailed questions about a specific redesign need to be answered.

8.2.2. Lessons learned

The Urban Water Optioneering Tool (UWOT) was chosen as the suitable tool for use in this project as it offers the capability of modelling both the supply and demand characteristics of the system within the same model. The limitations to the software are in the GIS capabilities and the economic assessment.

For the purpose of this project, it was only necessary to obtain the overall water balance scenarios, for which the UWOT tool satisfactorily achieves. The economic assessment was the only notable limitation which was overcome by performing hand calculations (not shown in the deliverable).



9. References

- A. Tritsis Management Board. (2022). Antonis Tritsis Environmental & Sensitization Park. www.parkotritsis.gr
- Ahmed, M., & Anwar, R. (2012). An assessment of the environmental impact of brine disposal in marine environment. *International Journal of Modern Engineering Research*, 2(4), 2756–2761.
- Bouziotas, D., Rozos, V., & Makropoulos, C. (2014). Water and the City: Exploring links between urban growth and water demand management. *Journal of Hydroinformatics*.
- Bouziotas, D., van Duuren, D., van Alphen, H.-J., Frijns, J., Nikolopoulos, D., Makropoulos, C., Bouziotas, D., van Duuren, D., van Alphen, H.-J., Frijns, J., Nikolopoulos, D., & Makropoulos, C. (2019). Towards Circular Water Neighborhoods: Simulation-Based Decision Support for Integrated Decentralized Urban Water Systems. *Water*, 11(6), 1227. <https://doi.org/10.3390/w11061227>
- Büttner, G., Feranec, J., Jaffrain, G., Mari, L., Maucha, G., & Soukup, T. (2004). The CORINE land cover 2000 project. *EARSeL EProceedings*, 3(3), 331–346.
- Curmi, E., Fenner, R., Richards, K., Allwood, J. M., Bajželj, B., & Kopec, G. M. (2013). Visualising a Stochastic Model of Californian Water Resources Using Sankey Diagrams. *Water Resources Management*, 27(8), 3035–3050. <https://doi.org/10.1007/s11269-013-0331-2>
- Dijcker, R., Roemers, G., van Nieuwenhuijzen, A., van Tuinen, E., Veldhoen, A., & Kennedy, E. (2017). *Delfland Circulair: Bouwstenen voor een strategie voor kringloopsluiting en zelfvoorzienendheid*.
- Dutch Waterboard Delfland website. (2020). <https://www.hhdelfland.nl/>
- Karim, M. R., Sadman Sakib, B. M., Sakib, S. S., & Imteaz, M. A. (2021). Rainwater harvesting potentials in commercial buildings in dhaka: Reliability and economic analysis. *Hydrology*, 8(1), 1–16. <https://doi.org/10.3390/hydrology8010009>
- Klein Tank, A., Beersma, J., Bessembinder, J., van den Hurk, B., & Lenderink, G. (2014). KNMI '14: climate scenarios for the Netherlands - a guide for professionals in climate adaption. KNMI. <http://edepot.wur.nl/328690>
- Krajenbrink, H., Stofberg, S., Bartholomeus, R., & Disselhoff, D. (2021). RWZI als waterfabriek voor een robuuste watervoorziening. <https://www.stowa.nl/publicaties/rwzi-als-waterfabriek-voor-een-robuuste-watervoorziening>
- Makropoulos, C. (2017). Thinking platforms for smarter urban water systems: fusing technical and socio-economic models and tools. *Geological Society, London, Special Publications*, 408(1), 201–219. <https://doi.org/10.1144/SP408.4>
- Makropoulos, C., Nikolopoulos, D., Palmen, L., Kools, S., Segrave, A., Vries, D., Koop, S., van Alphen, H. J., Vonk, E., van Thienen, P., Rozos, E., & Medema, G. (2018). A resilience assessment method for urban water systems. *Urban Water Journal*, 15(4), 316–328. <https://doi.org/10.1080/1573062X.2018.1457166>
- Moraitis, G., Nikolopoulos, D., Bouziotas, D., Lykou, A., Karavokiros, G., & Makropoulos, C. (2020). Quantifying Failure for Critical Water Infrastructures under Cyber-Physical Threats. *Journal of Environmental Engineering*, 146(9), 4020108.
- Nikolopoulos, D., Ostfeld, A., Salomons, E., & Makropoulos, C. (2021). Resilience assessment of water quality sensor designs under cyber-physical attacks. *Water*, 13(5), 647.
- Nikolopoulos, D., van Alphen, H.-J., Vries, D., Palmen, L., Koop, S., van Thienen, P., Medema, G., & Makropoulos, C. (2019). Tackling the “New Normal”: A Resilience Assessment Method



Applied to Real-World Urban Water Systems. *Water*, 11(2), 330. <https://doi.org/10.3390/w11020330>

Plevri, A., Lytras, E., Samios, S., Lioumis, C., Monokrousou, K., & Makropoulos, C. (2020). Sewer Mining as A Basis for Technological, Business and Governance Solutions for Water in the Circular Economy: The NextGen Athens Demo. *The 4th EWaS International Conference: Valuing the Water, Carbon, Ecological Footprints of Human Activities*, 54. <https://doi.org/10.3390/environsciproc2020002054>

Plevri, A., Samios, S., Lytras, E., Papadopoulos, K., Lioumis, C., Lazari, A., Tazes, N., Monokrousou, K., & Makropoulos, C. (2019). Installation of a Sewer Mining Unit in the Athens Urban Tree Nursery. *16th International Conference on Environmental Science and Technology*.

Pronk, G. J., Stofberg, S. F., van Dooren, T. C. G. W., Dingemans, M. M. L., Frijns, J., Koeman-Stein, N. E., Smeets, P. W. M. H., & Bartholomeus, R. P. (2021). Increasing Water System Robustness in the Netherlands: Potential of Cross-Sectoral Water Reuse. *Water Resources Management*, 35(11), 3721–3735. <https://doi.org/10.1007/s11269-021-02912-5>

Rozos, E., & Makropoulos, C. (2013). Source to tap urban water cycle modelling. *Environmental Modelling & Software*, 41, 139–150. <http://www.sciencedirect.com/science/article/pii/S1364815212002861>

Rozos, E., Makropoulos, C., & Maksimović, Č. (2013). Rethinking urban areas: an example of an integrated blue-green approach. *Water Science & Technology: Water Supply*, 13(6), 1534. <https://doi.org/10.2166/ws.2013.140>

Stofberg, S., Ros, S., Raat, K., Klooster, J., Ruepert, N., Agerbeek, B., Delsman, J., Bootsma, H., op den Kelder, T., & van der Veen, B. (2021). COASTAR Waterbank Westland. Droge voeten, voldoende gietwater.

Stofberg, S., & Zuurbier, K. G. (2018). COASTAR T2: Waterbank Westland.



10. Privacy Policy

NextGen Interactive Interface and applications Privacy Policy

By accepting to use NextGen Interactive Interface and applications you declare that I consent to the processing of:

- My email address,
- My company name,
- My Job Role,

so that I can use the NextGen Interactive Interface and applications.

I consent to the maintenance of my personal data until August 31, 2023

Purpose of data collection

NextGen Interactive Interface and applications are web-based application, targeted to all the stakeholders around the water Circular Economy.

During your registration to the NextGen Interactive Interface, you will be requested to provide your email, your company name, and your job role. This information is needed to allow you to use the applications and propose better and more relevant results to the search.). The personal data will not be transferred to third parties or external actors or projects.

Types of data collected

If you consent to the processing of your personal data for the above-mentioned purposes, the categories of personal data that will be collected and stored in the NextGen Interactive Interface are:

- My email address,
- My company name,
- My Job Role.

The Consortium will process the personal data of subjects according to the present statement and for the purposes declared herein.

Exercise of your rights

It is noted that according to the General Data Protection Regulation (Regulation (EU) 2016/679 of the European Parliament and of the Council of 27 April 2016), you may exercise the following rights that derive from the Regulation:

- Right of access and right to rectification for inaccurate personal data,
- Right to erasure of personal data if they are not necessary for service provision,
- Right to restrict processing of your data,
- Right to object to the processing of your data,
- Right to withdraw your consent to processing of your data,



- Right to data portability, namely right to receive your data in a structured, commonly used and machine-readable form so that they can be transferred to another data processor.
- Additionally, you have the right to submit a written complaint to the responsible supervisory body for personal data protection in each country.

The General Data Protection Regulation also gives you right to lodge a complaint with a supervisory authority, in particular in the European Union (or European Economic Area) state where you work, normally live or where any alleged infringement of data protection laws occurred.

